

EXTERIOR FINISHES

BASIS OF DESIGN: BASE BID

STONE: ALAMO STONE, COLOR= ALAMO CREAM
 FIBER CEMENT BOARD: HARDIE BOARD, COLOR= KHAKI BROWN
 STOREFRONT: ALUMINUM, COLOR = BLACK
 METAL WALL PANELS: BERRIDGE, COLOR = SIERRA TAN (EXISTING)
 METAL ROOF PANELS AND GUTTER: BERRIDGE, COLOR = FOREST GREEN (EXISTING)

ADD ALTERNATE:
 INSTALLATION OF NEW HORIZONTALLY ORIENTED METAL WALL PANELS AND AN OVERLAY METAL ROOF PANEL SYSTEM TO THE ENTIRETY OF THE EXISTING BUILDINGS.
 METAL WALL PANELS: BERRIDGE, COLOR = CITYSCAPE (ADD ALTERNATE)
 METAL ROOF PANELS AND GUTTER: BERRIDGE, COLOR = CHARCOAL GREY (ADD ALTERNATE)

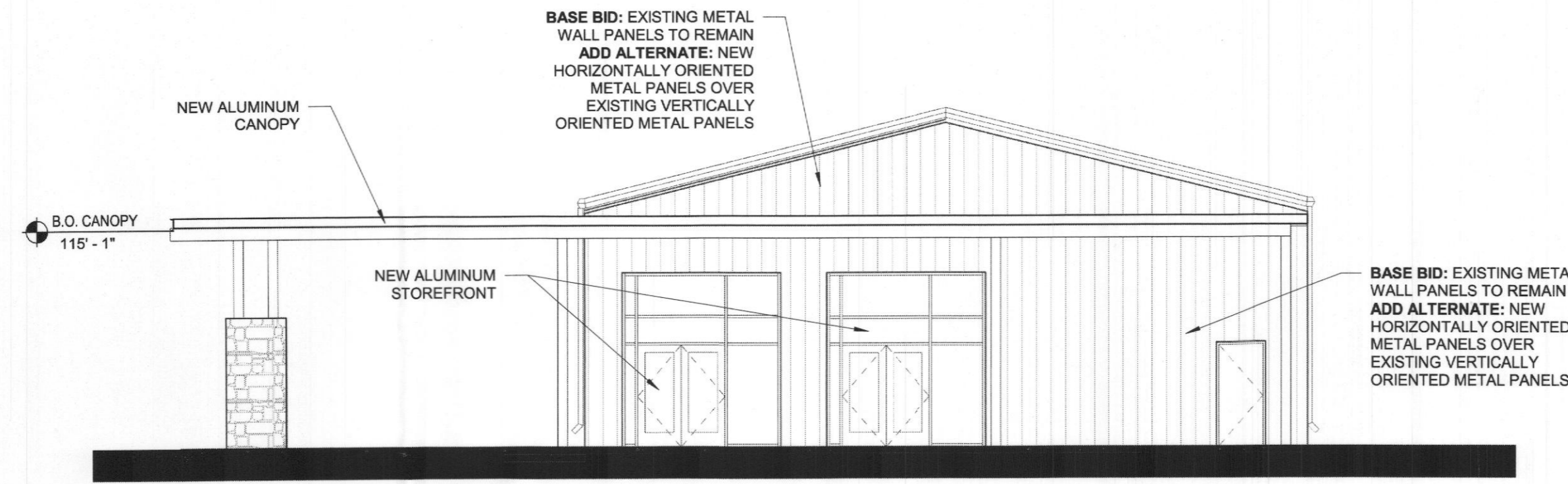

SOUTH ELEVATION - BUILDING 01 | 4
 SCALE: 1/8" = 1'-0" A3.00

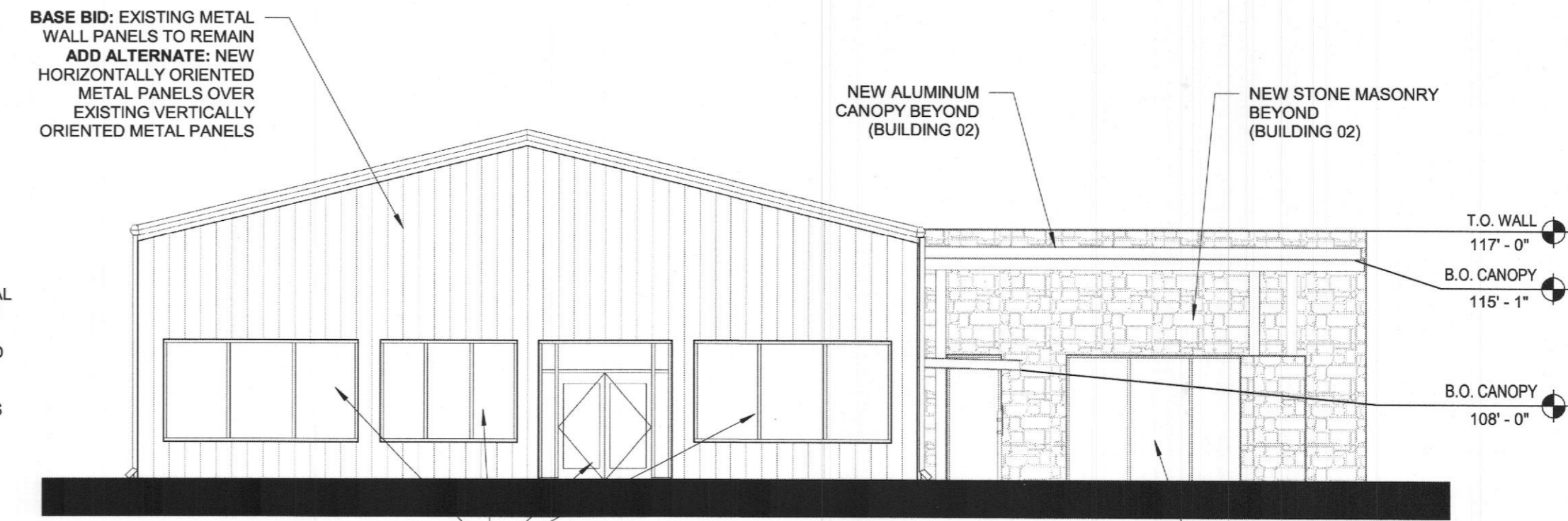

NORTH ELEVATION - BUILDING 01 | 3
 SCALE: 1/8" = 1'-0" A3.00

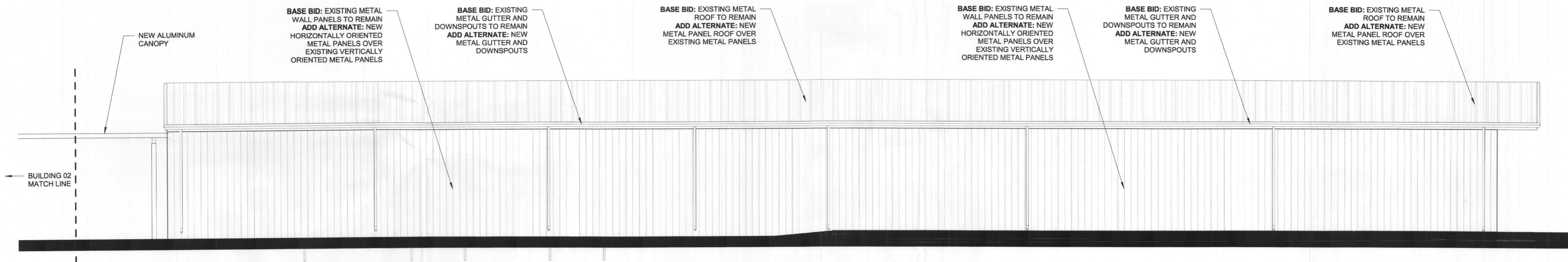

EAST ELEVATION - BUILDING 01 | 2
 SCALE: 1/8" = 1'-0" A3.00

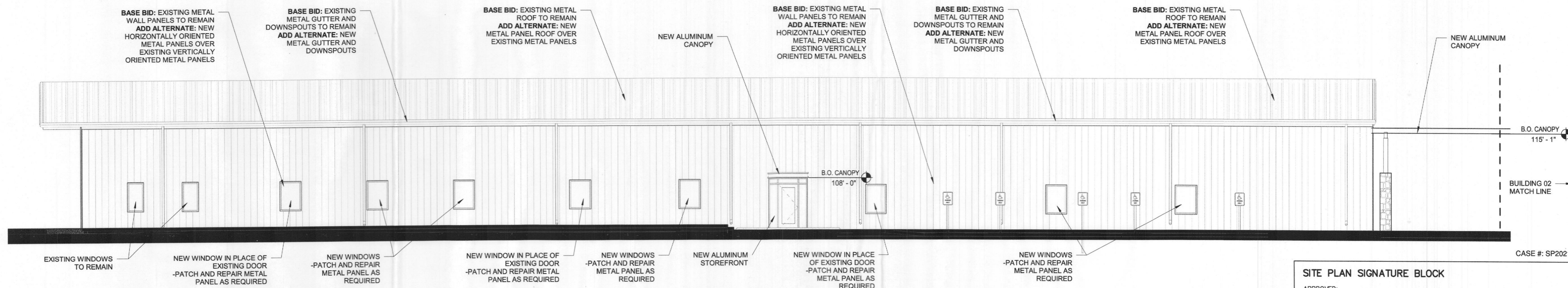

WEST ELEVATION - BUILDING 01 | 1
 SCALE: 1/8" = 1'-0" A3.00

SITE PLAN SIGNATURE BLOCK

APPROVED:
 I HEREBY CERTIFY THAT THE ABOVE AND FOREGOING SITE PLAN FOR A DEVELOPMENT IN THE CITY OF ROCKWALL, TEXAS, WAS APPROVED BY THE PLANNING & ZONING COMMISSION OF THE CITY OF ROCKWALL ON THE 16 DAY OF April, 2021.
 WITNESS OUR HANDS, THIS 16 DAY OF April, 2021.
 [Signature] DIRECTOR OF PLANNING & ZONING
 [Signature] PLANNING & ZONING COMMISSION, CHAIRMAN

FOR INTERIM REVIEW ONLY, NOT TO BE USED FOR PERMITTING OR CONSTRUCTION
 ANDREW OXLEY

DRAWINGS, SPECIFICATIONS AND OTHER DOCUMENTS, PREPARED BY OXLEY WILLIAMS THARP ARCHITECTS, PLLC ARE INSTRUMENTS OF SERVICE FOR USE SOLELY WITH RESPECT TO THIS PROJECT. THIS INCLUDES DOCUMENTS IN ELECTRONIC FORM. OXLEY WILLIAMS THARP ARCHITECTS, PLLC SHALL BE DEEMED THE AUTHORS AND OWNERS OF THEIR RESPECTIVE INSTRUMENTS OF SERVICE AND SHALL RETAIN ALL COMMON LAW, STATUTORY AND OTHER RESERVED RIGHTS, INCLUDING COPYRIGHTS. THE INSTRUMENTS OF SERVICE SHALL NOT BE USED BY THE OWNER FOR FUTURE ADDITIONS OR ALTERATIONS TO THIS PROJECT OR FOR OTHER PROJECTS. WITHOUT THE PRIOR WRITTEN AGREEMENT OF OXLEY WILLIAMS THARP ARCHITECTS, PLLC, ANY UNAUTHORIZED USE OF THE INSTRUMENTS OF SERVICE SHALL BE WITHOUT LIABILITY TO OXLEY WILLIAMS THARP ARCHITECTS, PLLC AND ITS CONSULTANTS.

Revision Schedule		
Rev. #	Revision Description	Revision Date
1	Revision 1	Date 1

GOFF COMPANIES

OWT ARCHITECTS

509 PECAN STREET
 SUITE 100
 FORT WORTH, TX 76102
 817.993.9844

www.owtarchitects.com

ROCKWALL FRIENDSHIP BAPTIST CHURCH

5651 TX-276
 ROYSE CITY, TX 75189

2020-013-00
 MARCH 19, 2021

EXTERIOR ELEVATIONS - BLDG 01

A3.00

CASE #: SP2021-008

EXTERIOR FINISHES

BASIS OF DESIGN: BASE BID

STONE: ALAMO STONE, COLOR= ALAMO CREAM
 FIBER CEMENT BOARD: HARDIE BOARD, COLOR= KHAKI BROWN
 STOREFRONT: ALUMINUM, COLOR = BLACK
 METAL WALL PANELS: BERRIDGE, COLOR = SIERRA TAN (EXISTING)
 METAL ROOF PANELS AND GUTTER: BERRIDGE, COLOR = FOREST GREEN (EXISTING)

ADD ALTERNATE:
 INSTALLATION OF NEW HORIZONTALLY ORIENTED METAL WALL PANELS AND AN OVERLAY METAL ROOF PANEL SYSTEM TO THE ENTIRETY OF THE EXISTING BUILDINGS.

METAL WALL PANELS: BERRIDGE, COLOR = CITYSCAPE (ADD ALTERNATE)
 METAL ROOF PANELS AND GUTTER: BERRIDGE, COLOR = CHARCOAL GREY (ADD ALTERNATE)

MASONRY CALCULATIONS

ADDITION ONLY:

NORTH: 355 SF
 FIBER CEMENT BOARD = 0 (0%)
 STONE = 355 (100%)

SOUTH: 248 SF
 FIBER CEMENT BOARD = 0 (0%)
 STONE = 248 (100%)

WEST: 1,193 SF
 FIBER CEMENT BOARD = 638 (53.5%)
 STONE = 555 (46.5%)

EAST: N/A

TOTAL: 1,796 SF
 FIBER CEMENT BOARD = 638 (35.5%)
 STONE = 1,158 (64.5%)

*TOTALS AND PERCENTAGES DO NOT INCLUDE GLAZING SQUAREFOOTAGES.

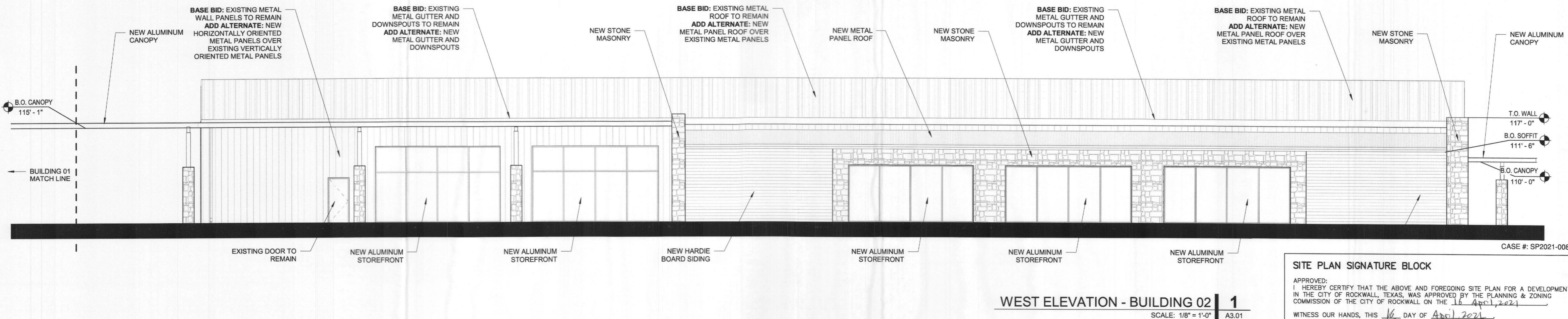
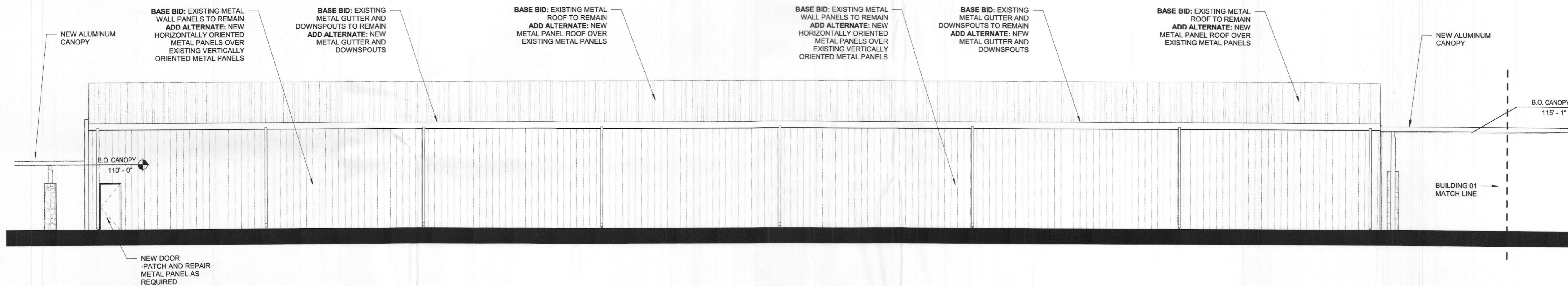
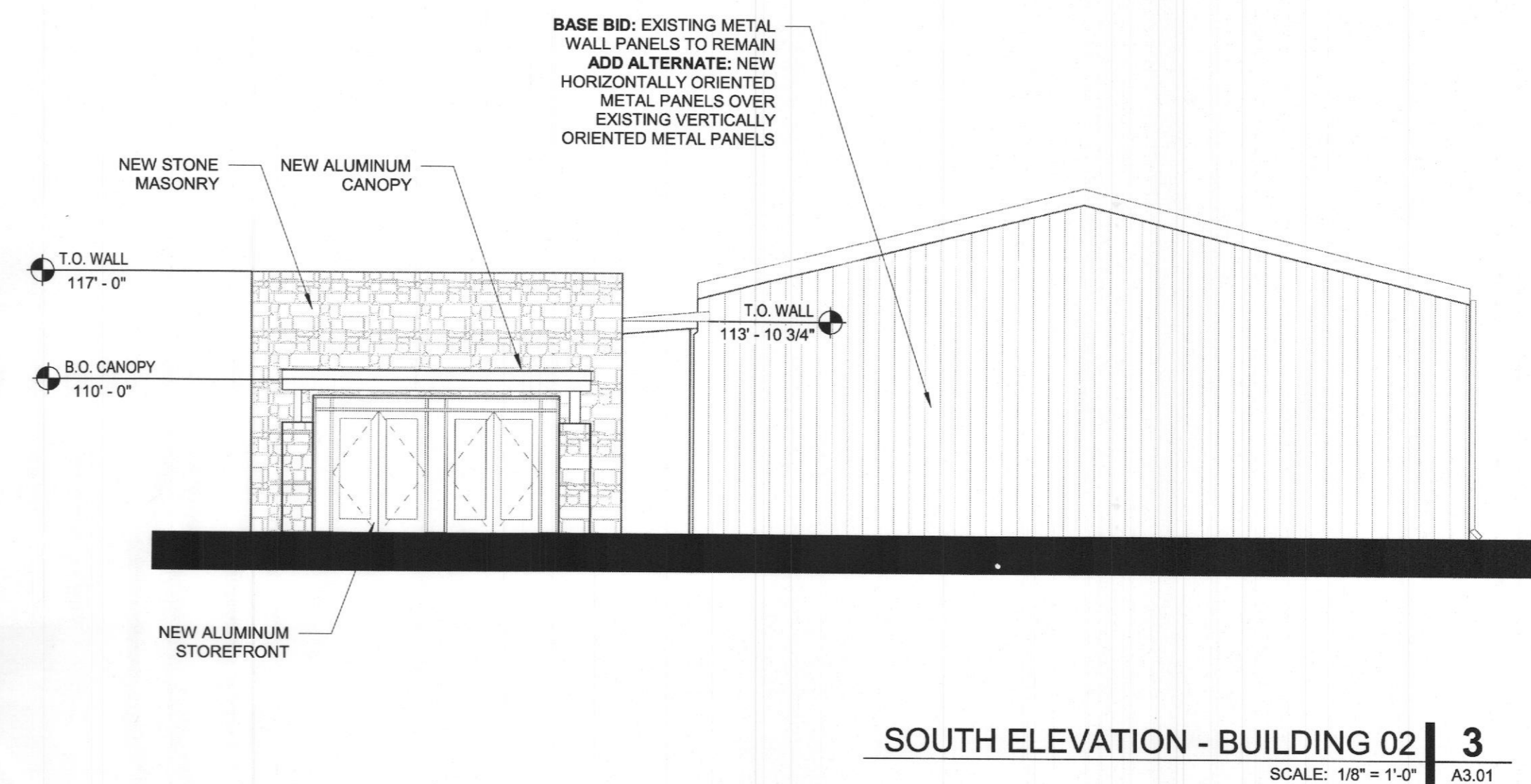
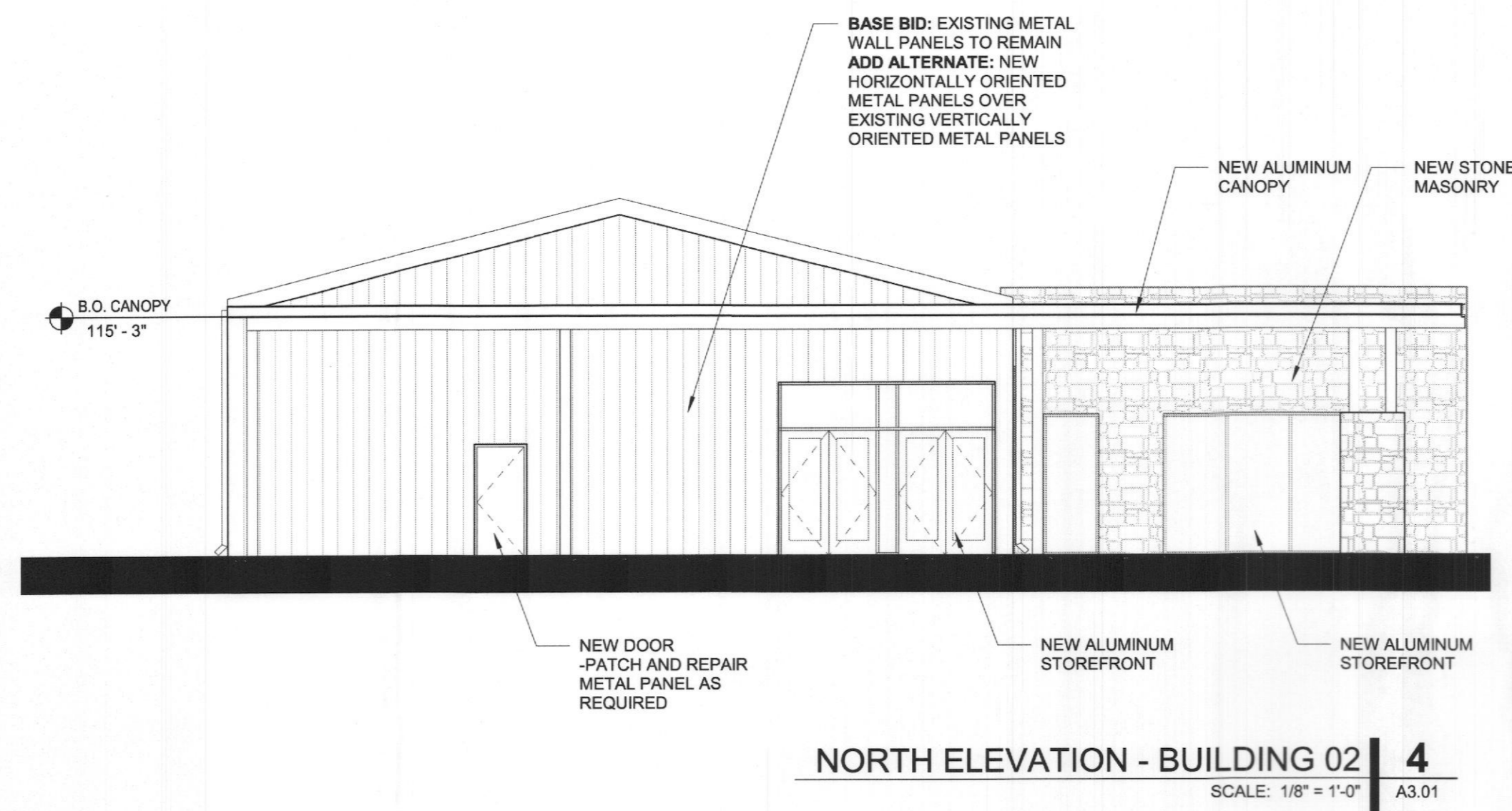

SITE PLAN SIGNATURE BLOCK
 APPROVED:
 I HEREBY CERTIFY THAT THE ABOVE AND FOREGOING SITE PLAN FOR A DEVELOPMENT IN THE CITY OF ROCKWALL, TEXAS, WAS APPROVED BY THE PLANNING & ZONING COMMISSION OF THE CITY OF ROCKWALL ON THE 16 DAY OF April, 2021.
 WITNESS OUR HANDS, THIS 16 DAY OF April, 2021.
 [Signature] DIRECTOR OF PLANNING & ZONING
 [Signature] PLANNING & ZONING COMMISSION, CHAIRMAN

FOR INTERIM REVIEW ONLY, NOT TO BE USED FOR PERMITTING OR CONSTRUCTION
 ANDREW OXLEY

DRAWINGS, SPECIFICATIONS AND OTHER DOCUMENTS, PREPARED BY OXLEY WILLIAMS THARP ARCHITECTS, PLLC ARE INSTRUMENTS OF SERVICE FOR USE SOLELY WITH RESPECT TO THIS PROJECT. THIS INCLUDES DOCUMENTS IN ELECTRONIC FORM. OXLEY WILLIAMS THARP ARCHITECTS, PLLC SHALL BE DEEMED THE AUTHORS AND OWNERS OF THEIR RESPECTIVE INSTRUMENTS OF SERVICE AND SHALL RETAIN ALL COMMON LAW, STATUTORY AND OTHER RESERVED RIGHTS, INCLUDING COPYRIGHTS. THE INSTRUMENTS OF SERVICE SHALL NOT BE USED BY THE OWNER FOR FUTURE ADDITIONS OR ALTERATIONS TO THIS PROJECT OR FOR OTHER PROJECTS, WITHOUT THE PRIOR WRITTEN AGREEMENT OF OXLEY WILLIAMS THARP ARCHITECTS, PLLC. ANY UNAUTHORIZED USE OF THE INSTRUMENTS OF SERVICE SHALL BE WITHOUT LIABILITY TO OXLEY WILLIAMS THARP ARCHITECTS, PLLC AND ITS CONSULTANTS.

Revision Schedule		
Rev. #	Revision Description	Revision Date

GOFF COMPANIES

OWT ARCHITECTS

509 PECAN STREET SUITE 100 FORT WORTH, TX 76102 817.993.9644

www.owtarchitects.com

ROCKWALL FRIENDSHIP BAPTIST CHURCH

5651 TX-276 ROYSE CITY, TX 75189

2020-013-00 MARCH 19, 2021

EXTERIOR ELEVATIONS - BLDG 02

A3.01

FOR INTERIM REVIEW ONLY, NOT TO BE USED FOR PERMITTING OR CONSTRUCTION

ANDREW OXLEY

DRAWINGS, SPECIFICATIONS AND OTHER DOCUMENTS, PREPARED BY OXLEY WILLIAMS THARP ARCHITECTS, PLLC ARE INSTRUMENTS OF SERVICE FOR USE SOLELY WITH RESPECT TO THIS PROJECT. THIS INCLUDES DOCUMENTS IN ELECTRONIC FORM. OXLEY WILLIAMS THARP ARCHITECTS, PLLC SHALL BE DEEMED THE AUTHORS AND OWNERS OF THEIR RESPECTIVE INSTRUMENTS OF SERVICE AND SHALL RETAIN ALL COMMON LAW, STATUTORY AND OTHER RESERVED RIGHTS, INCLUDING COPYRIGHTS. THE INSTRUMENTS OF SERVICE SHALL NOT BE USED BY THE OWNER FOR FUTURE ADDITIONS OR ALTERATIONS TO THIS PROJECT OR FOR OTHER PROJECTS WITHOUT THE PRIOR WRITTEN AGREEMENT OF OXLEY WILLIAMS THARP ARCHITECTS, PLLC. ANY UNAUTHORIZED USE OF THE INSTRUMENTS OF SERVICE SHALL BE WITHOUT LIABILITY TO OXLEY WILLIAMS THARP ARCHITECTS, PLLC AND ITS CONSULTANTS.

Revision Schedule

Rev. #	Revision Description	Revision Date

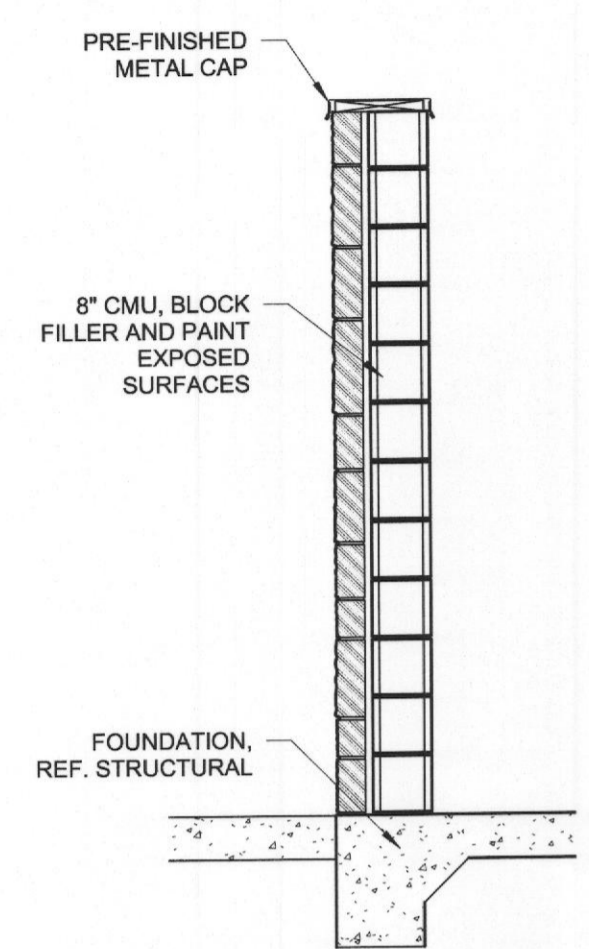

DUMPSTER SECTION | 7
SCALE: 1/2" = 1'-0" | A1.01

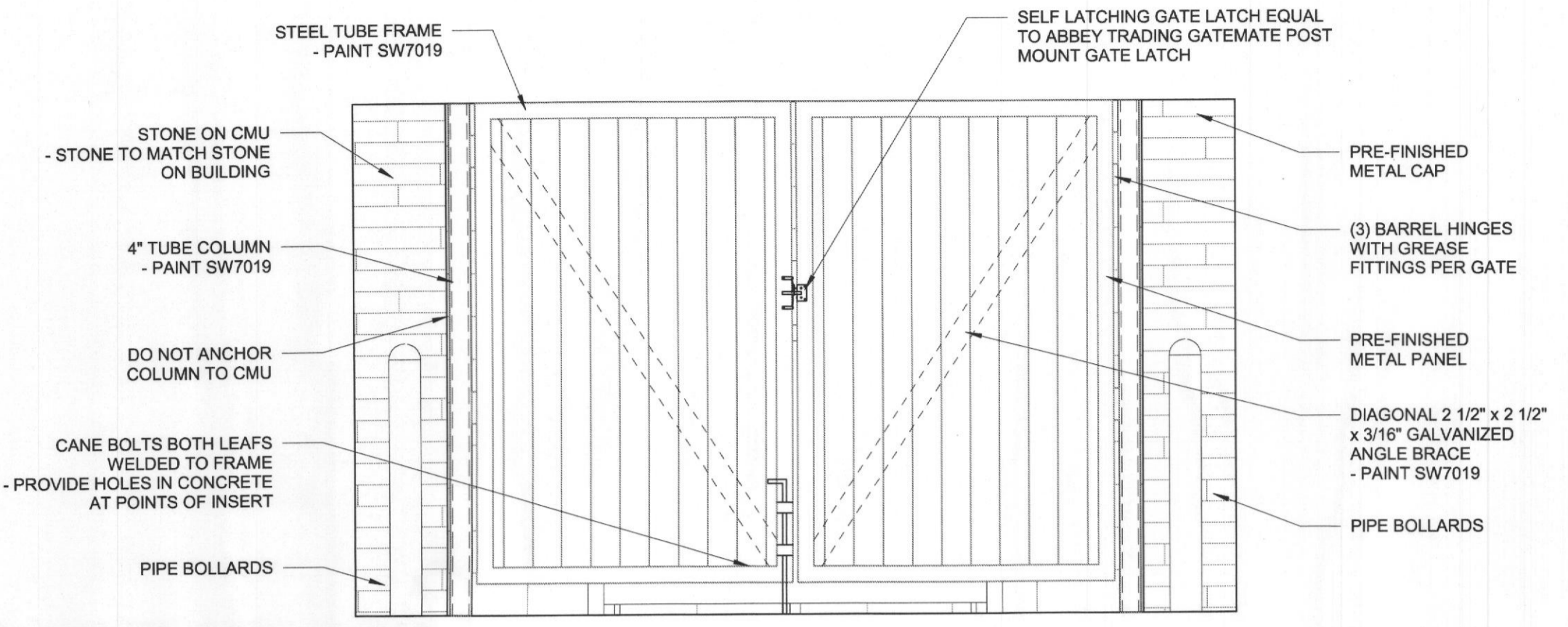

DUMPSTER ENCLOSURE ELEVATION | 6
SCALE: 1/2" = 1'-0" | A1.01

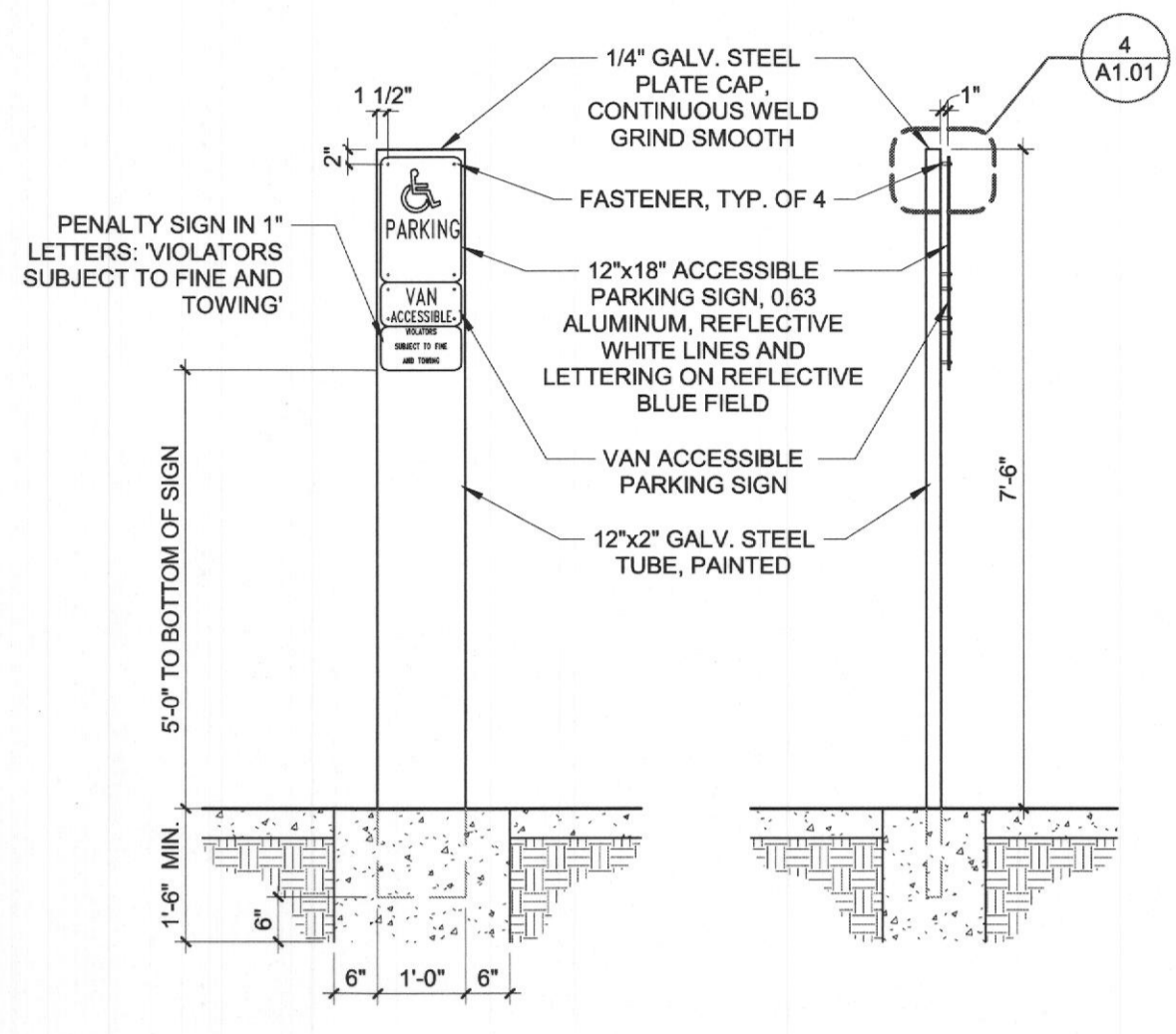

VAN ACCESSIBLE PARKING SIGN | 5
SCALE: 1/2" = 1'-0" | A1.01

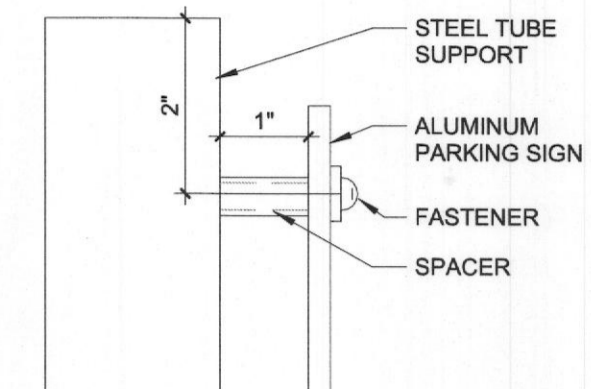

PARKING SIGN DETAIL | 4
SCALE: 6" = 1'-0" | A1.01

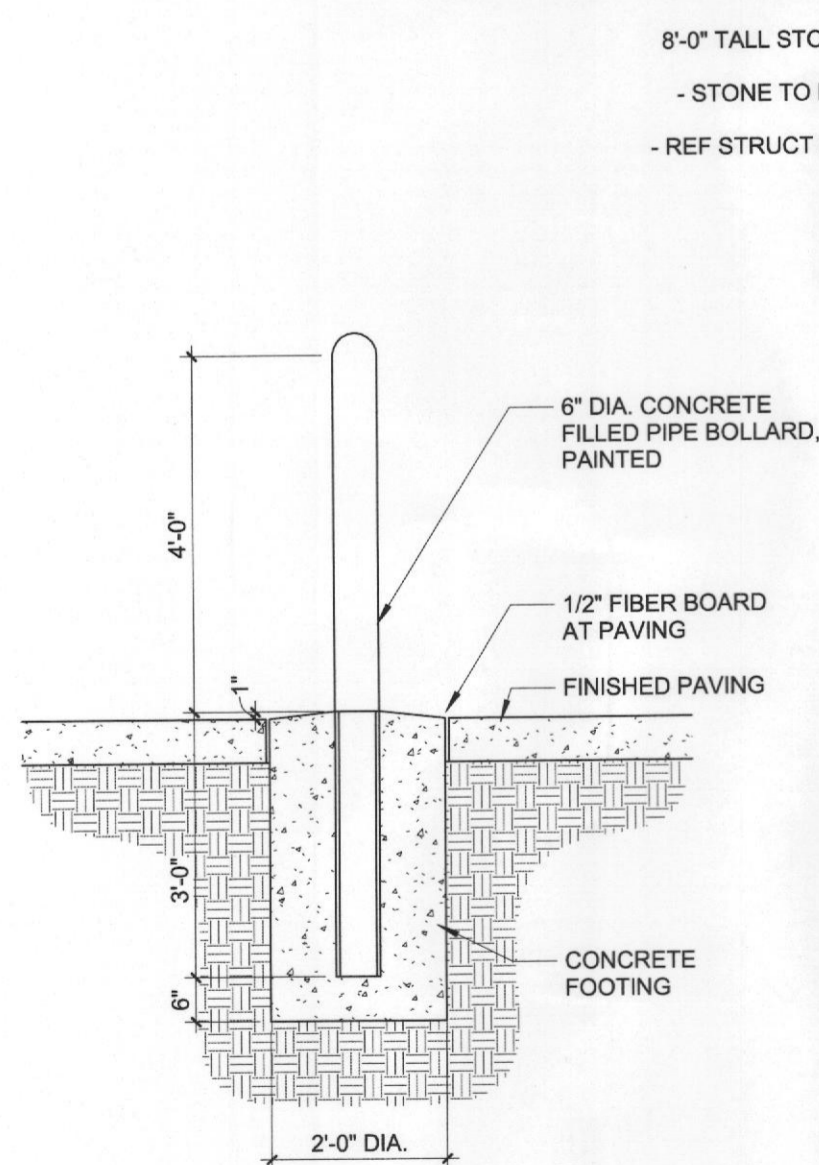

BOLLARD DETAIL | 3
SCALE: 1/2" = 1'-0" | A1.01

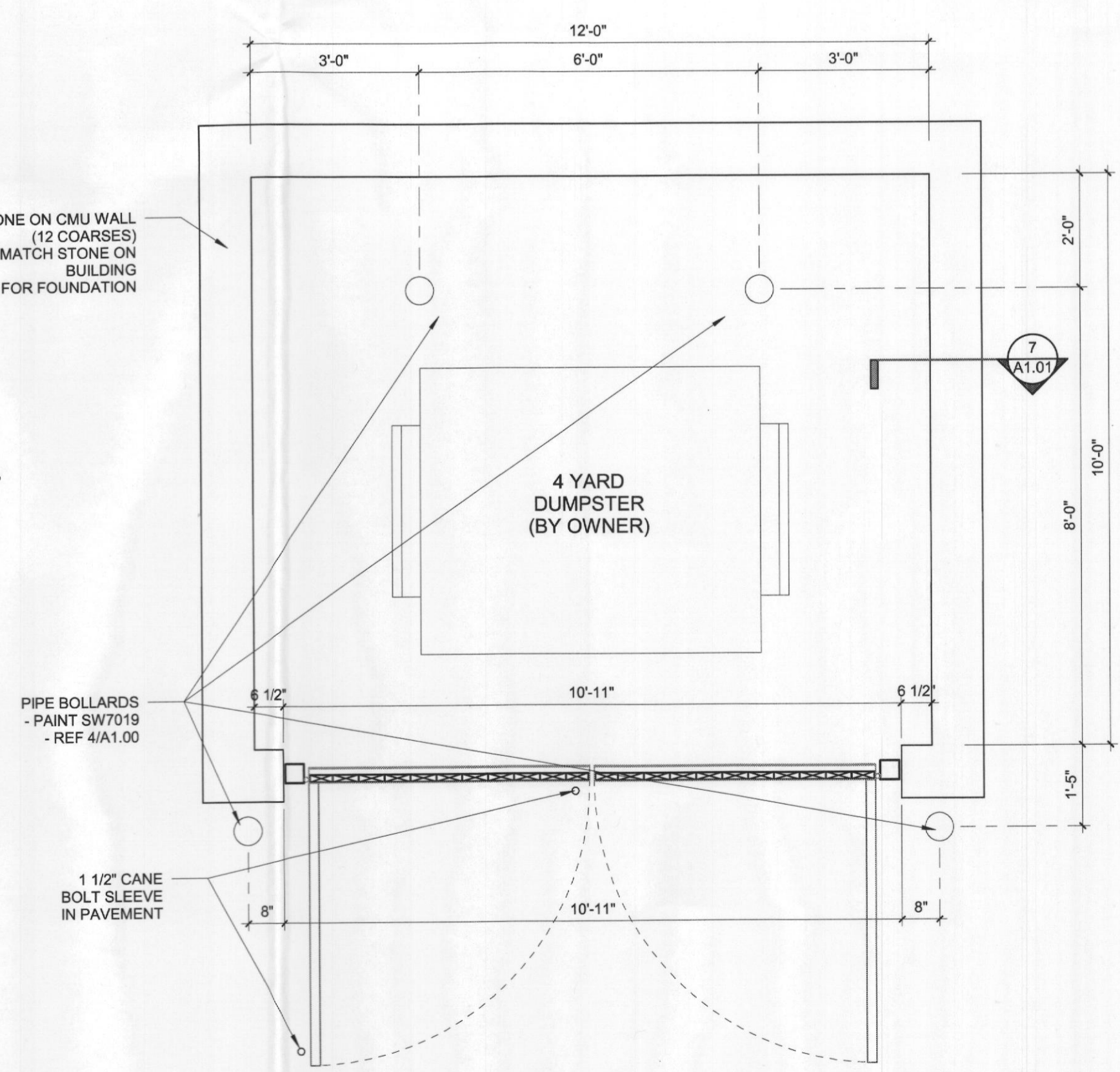

ENLARGED DUMPSTER ENCLOSURE | 2
SCALE: 1/2" = 1'-0" | A1.01

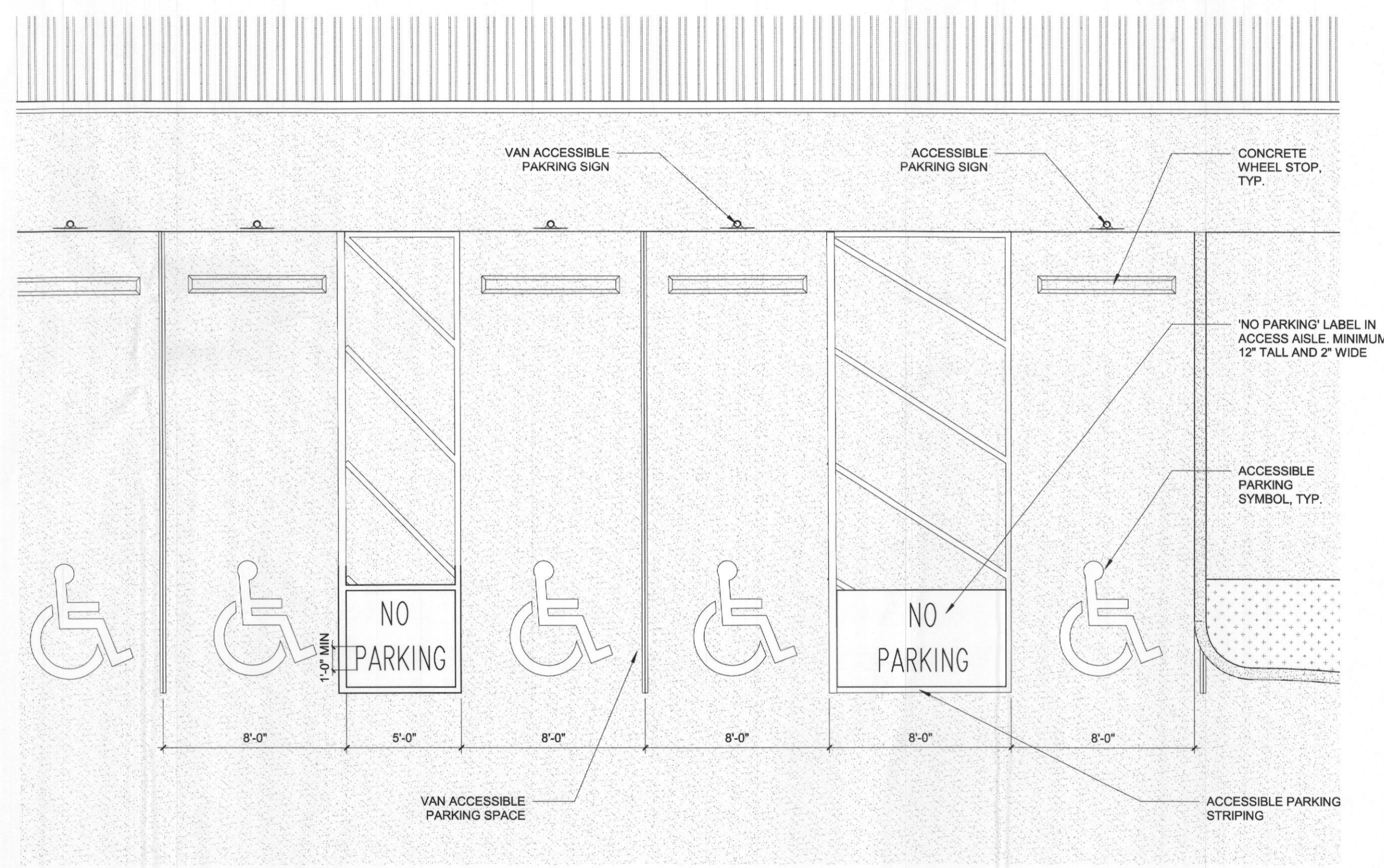

ACCESSIBLE PARKING | 1
SCALE: 1/4" = 1'-0" | A1.01

SITE PLAN SIGNATURE BLOCK
APPROVED:
I, HEREBY CERTIFY THAT THE ABOVE AND FOREGOING SITE PLAN FOR A DEVELOPMENT IN THE CITY OF ROCKWALL, TEXAS, WAS APPROVED BY THE PLANNING & ZONING COMMISSION OF THE CITY OF ROCKWALL ON THE 16 DAY OF April, 2021.
WITNESS OUR HANDS, THIS 16 DAY OF April, 2021.
PLANNING & ZONING COMMISSION, CHAIRMAN
DIRECTOR OF PLANNING & ZONING

GOFF COMPANIES

OWT ARCHITECTS

509 PECAN STREET
SUITE 100
FORT WORTH, TX 76102
817.993.9844
www.owtarchitects.com

ROCKWALL
FRIENDSHIP
BAPTIST CHURCH

5651 TX-276
ROYSE CITY, TX 75189

2020-013-00
APRIL 8, 2021

SITE DETAILS

A1.01

H PROJECT INFORMATION

PROJECT NAME - ROCKWALL FRIENDSHIP BAPTIST CHURCH
 PROPOSED LAND USE - CHURCH
 ZONING DISTRICT - COMMERCIAL (C)
 OVERLAY - sh 276 OVERLAY
 TOTAL SITE AREA - 3.94 ACRES - 171,626 SQUARE FEET
 IMPREVIOUS SURFACE - 51.5% - 2.03 ACRE
 PREVIOUS SURFACE - 48.5% - 1.91 ACRE
 ADDITIONAL SQUARE FOOTAGE - 3,500 SQUARE FEET
 TOTAL SQUARE FOOTAGE - 23,500 SQUARE FEET
 TOTAL GROSS INTENSITY (FAR) 0.14 OR 14%
 SANCTUARY SEATING - 400 SEATS
 MINIMUM LOT COVERAGE - 60%
 MINIMUM LOT AREA - 10,000
 MINIMUM LOT WIDTH - 60
 MINIMUM LOT DEPTH - 100
 SETBACKS
 FRONT - 25
 REAR - 20
 SIDE - 0
 MINIMUM LOT DEPTH - 100
 STRUCTURE HEIGHT 240' MAX
 REQUIRED PARKING - 100
 400 SEATS AT 1 PER 4 SEATS
 PARKING PROVIDED 115
 4 HANDICAP PARKING - REGULAR
 3 HANDICAP PARKING - VAN

D PLANTING GENERAL NOTES

1. ALL SOIL EXCAVATION MAY BE DISPOSED OF ON SITE.
2. IF A LIVE UTILITY IS ENCOUNTERED DURING EXCAVATION, CONTACT OWNER'S REPRESENTATIVE.
3. SEE PLANTING SPECIFICATIONS FOR A COMPLETE DESCRIPTION OF PLANT MATERIAL AND INSTALLATION.
4. ALL BEDS MUST BE LAID OUT AND APPROVED PRIOR TO THE INSTALLATION OF THE IRRIGATION FOR COORDINATION.
5. ALL PLANT MATERIAL SHALL BE STAKED AND APPROVED BY THE LANDSCAPE ARCHITECT PRIOR TO PLANT INSTALLATION.
6. ALL PLANTING DETAILS ARE TYPICAL.
7. ALL DISTURBED AREAS WITHIN THE PROJECT LIMITS MUST BE EITHER HYDROMULCHING OR SOLID SODDED UNLESS NOTED.

C PREPARATION GENERAL NOTES

1. PLAN PREPARED BY:
 MICHAEL S. KENDALL
 KENDALL + LANDSCAPE ARCHITECTURE
 6976 SANTA BARBARA
 DALLAS, TEXAS 75214
 PHONE: (214) 739-3226
 E-MAIL: MIKE@KENDALL7.COM
 TEXAS LANDSCAPE ARCHITECT LICENSE NO. 1127
2. ALL AREAS SHALL BE IRRIGATED BY A LICENCED IRRIGATOR WITH AN AUTOMATIC UNDERGROUND IRRIGATION SYSTEM PROVIDING 100% COVERAGE. FOLLOW UDC REQUIREMENTS.
3. ALL REQUIRED TREES FROM THE CITY APPROVED LISTING.
4. IRRIGATION WILL MEET THE REQUIREMENTS OF UDC.
5. NO TREES WITHIN 5' OF ANY UTILITIES.



FRIENDSHIP BAPTIST CHURCH
ROCKWALL, TEXAS

E LOCATION MAP

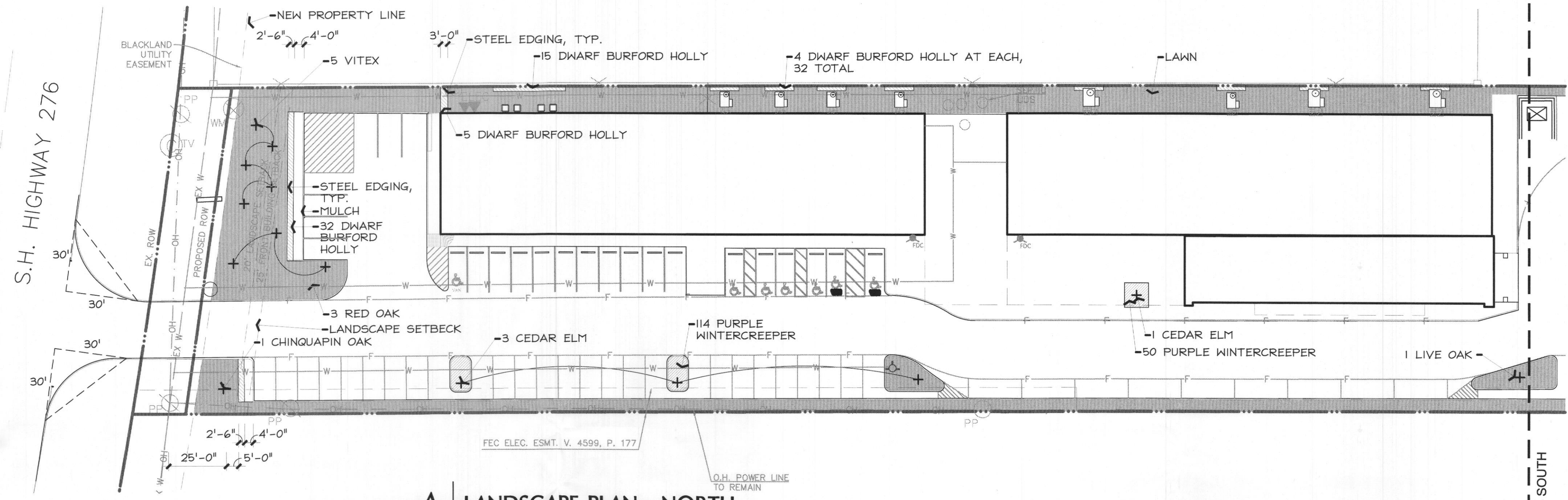
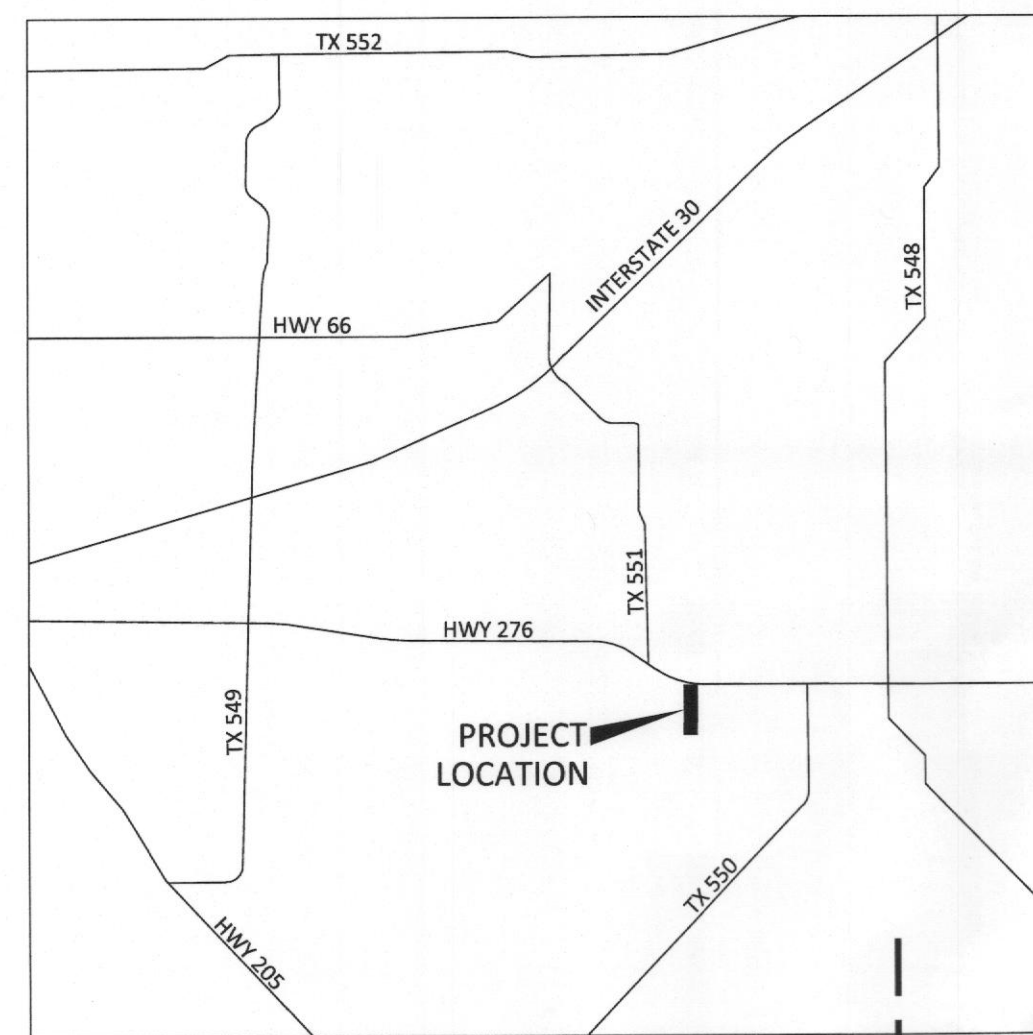

A LANDSCAPE PLAN - NORTH
 1" = 30'-0"

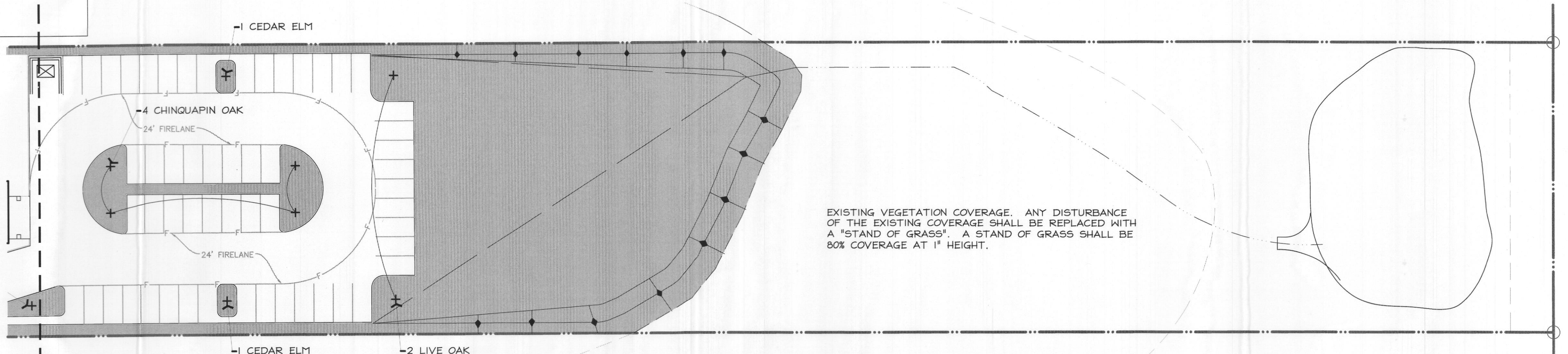

B LANDSCAPE PLAN - SOUTH
 1" = 30'-0"

EXISTING VEGETATION COVERAGE. ANY DISTURBANCE OF THE EXISTING COVERAGE SHALL BE REPLACED WITH A "STAND OF GRASS". A STAND OF GRASS SHALL BE 80% COVERAGE AT 1" HEIGHT.

LANDSCAPE PLAN SIGNATURE BLOCK
 APPROVED:
 I HEREBY CERTIFY THAT THE ABOVE AND FOREGOING LANDSCAPE PLAN FOR A DEVELOPMENT IN THE CITY OF ROCKWALL, TEXAS, WAS APPROVED BY THE PLANNING & ZONING COMMISSION OF THE CITY OF ROCKWALL ON THE 16 DAY OF April, 2021.
 WITNESS OUR HANDS, THIS 16 DAY OF April, 2021.
 [Signature] PLANNING & ZONING COMMISSION, CHAIRMAN
 [Signature] DIRECTOR OF PLANNING & ZONING

ROCKWALL FRIENDSHIP BAPTIST CHURCH
VOL. 1084, PG 266 D.R.R.C.T.
CASE - SP2021-XXX

Seal
Revisions
Issue Date
18 March 2021
Sheet Name
LANDSCAPE PLAN
Sheet Number
L11

G ORDINANCE REQUIREMENT

Mandatory Provisions

1. 15' landscape buffer Provided.			
2. Screening of off-street loading areas Provided.			
3. Residential Adjacency 6' masonry fencing	n/a		
4. Buffer landscaping 1 tree per 50' linear feet	136 / 50	3 3" caliper trees required 3 3" caliper trees provided	
5. Parking lot landscaping 5% required	75,000	*.05 3,750 required area 4,228 provided area	
6. Open space F1 Zoning	171,626	*.08 13,730 square feet required 74,052 square feet provided	
7. SH 270 Overlay District Planting at Buffer	136 / 50	3 4" caliper trees required 4 4" caliper trees provided	
	136 / 25	5 Accent Trees required 5 Accent Trees provided	

H PLANT LISTING

ALL SIZES SHOWN ARE MINIMUM. SMALLER CONTAINERS MEETING THE SPECIFIED HEIGHT AND SPREAD WILL NOT BE ACCEPTED. IF QUANTITIES ARE SHOWN, CONTRACTOR IS RESPONSIBLE FOR VERIFYING QUANTITIES. PLAN REFERENCES GOVERN.

BOTANIC NAME	COMMON NAME	SIZE	DESCRIPTION	QUANTITY
LARGE TREES				
QUERCUS PHELLOS	CHINQUAPIN OAK	100 GALLON CONTAINER, 4"-4 1/2" CALIPER, 9' - 10' HEIGHT, 5'-6' SPREAD	SINGLE STRAIGHT LEADER.	5
QUERCUS SHUMARDII	SHUMARD RED OAK	100 GALLON CONTAINER, 4"-4 1/2" CALIPER, 9' - 10' HEIGHT, 5'-6' SPREAD	SINGLE STRAIGHT LEADER.	3
QUERCUS VIRGINIANA	LIVE OAK	100 GALLON CONTAINER, 4"-4 1/2" CALIPER, 9' - 10' HEIGHT, 5'-6' SPREAD	SINGLE STRAIGHT LEADER.	3
ULMUS CRASSIFOLIA	CEDAR ELM	100 GALLON CONTAINER, 4"-4 1/2" CALIPER, 9' - 10' HEIGHT, 5'-6' SPREAD	SINGLE STRAIGHT LEADER.	6
ORNAMENTAL TREES				
VITEX AGNUS-CASTUS	VITEX	65 GALLON CONTAINER, 3"-3 1/2" CALIPER, 7' - 8' HEIGHT, 5'-7' SPREAD	MULTI-TRUNK - 3 CANES MAXIMUM	5
SHRUBS				
ILEX CRENATA BURFORDII NANA	DWARF BURFORD HOLLY	5 GALLON	24" ON CENTER	64
GROUNDCOVER / PERINNEL				
EUONYMUS COLORATA	PURPLE WINTERCREEPER	1 GALLON	18" ON CENTER	162
LAWN				
CYNDON	SOLID SOD OR HYDROMULCH BERMUDA			



FRIENDSHIP BAPTIST CHURCH
ROCKWALL, TEXAS

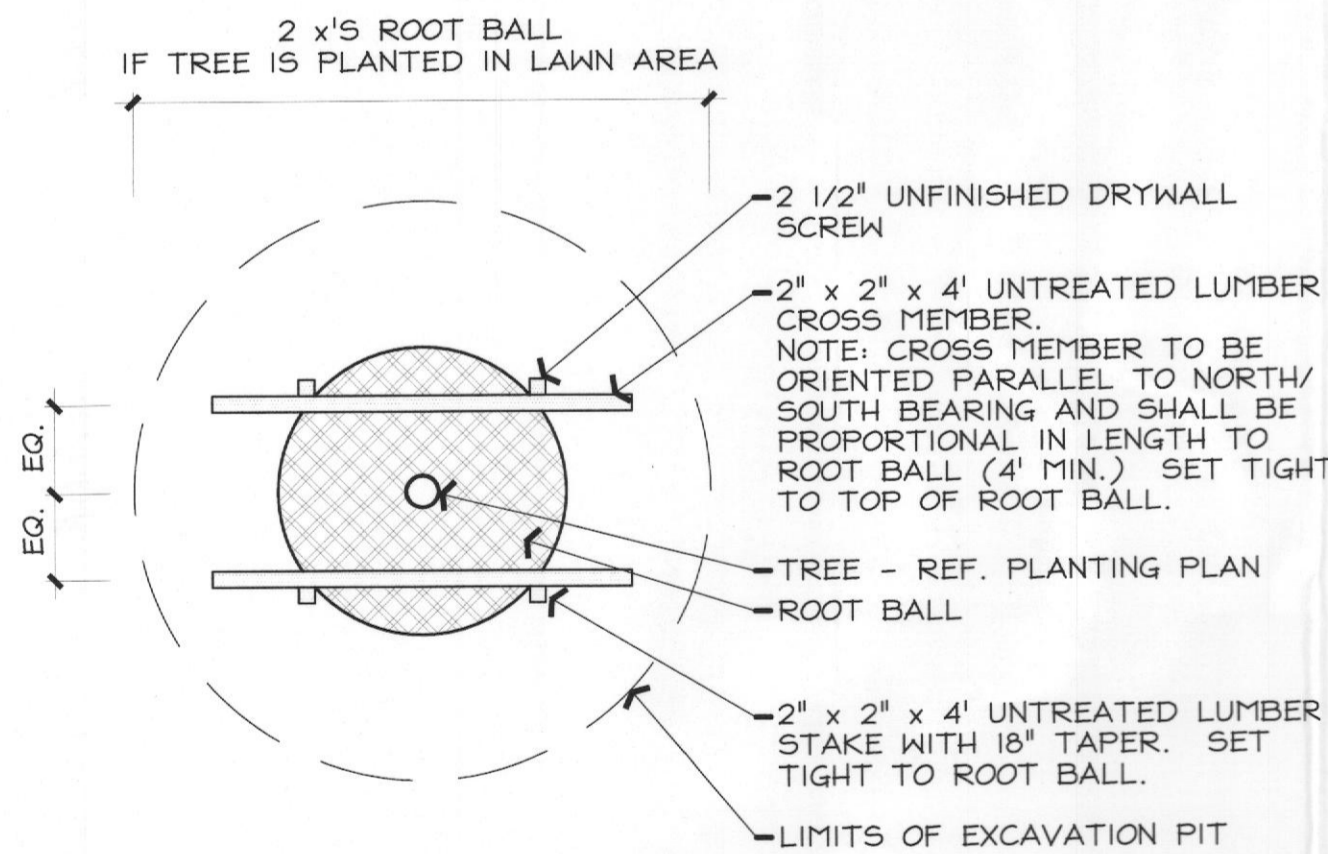

A TYPICAL TREE STAKING - PLAN
1/2" = 1'-0"

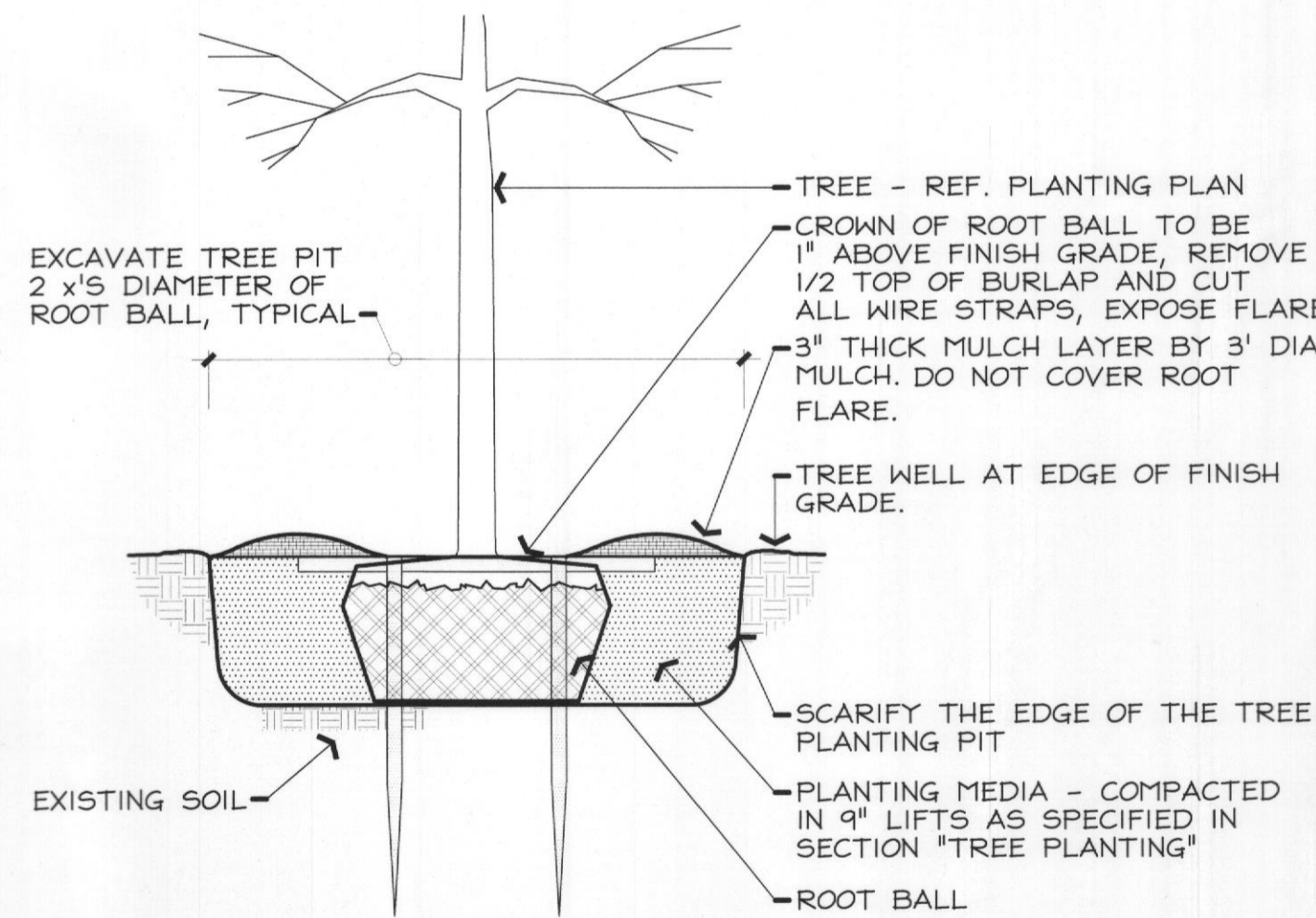

B TREE PLANTING IN LAWN - SECTION
1/2" = 1'-0"

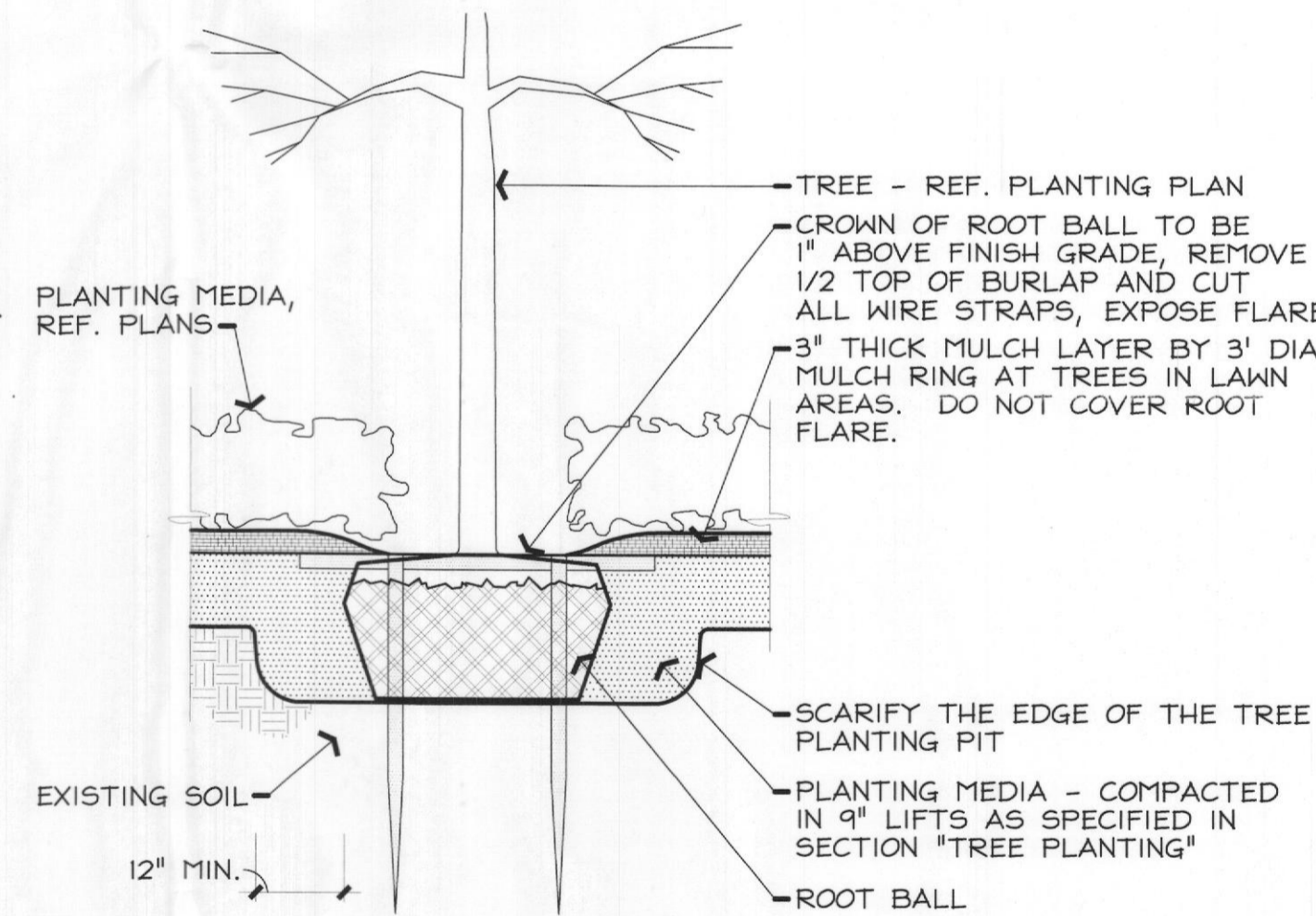

C TREE PLANTING IN PLANTER - SECTION
1/2" = 1'-0"

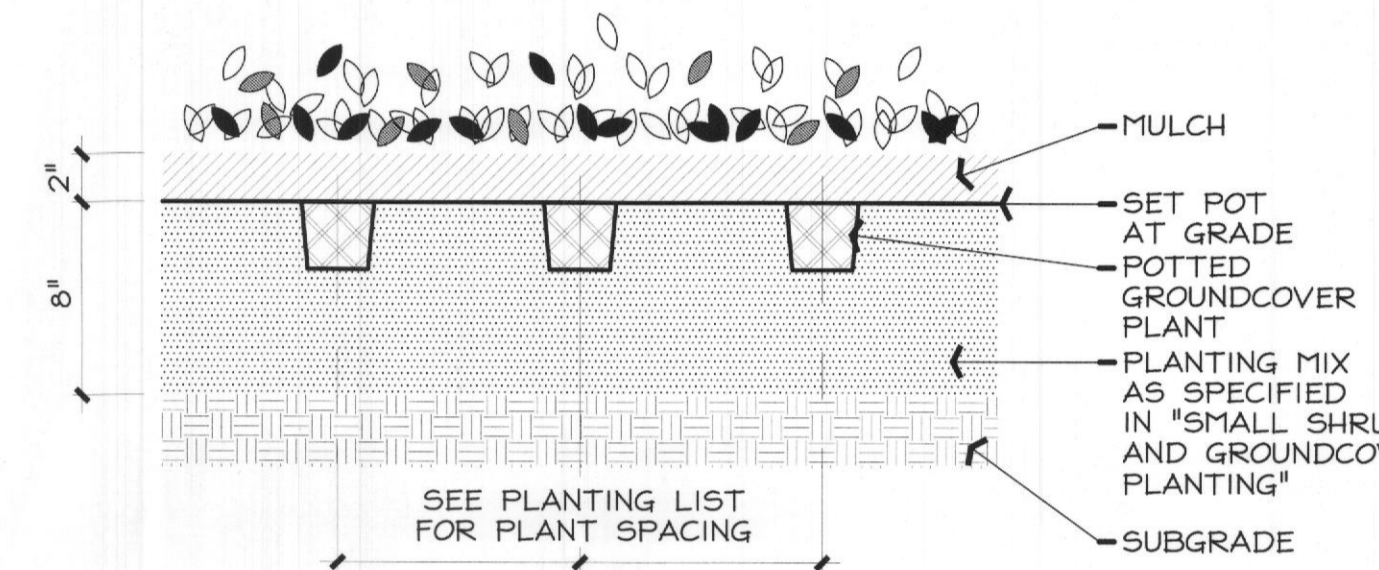

E GROUNDCOVER PLANTING - SECTION
1 1/2" = 1'-0"

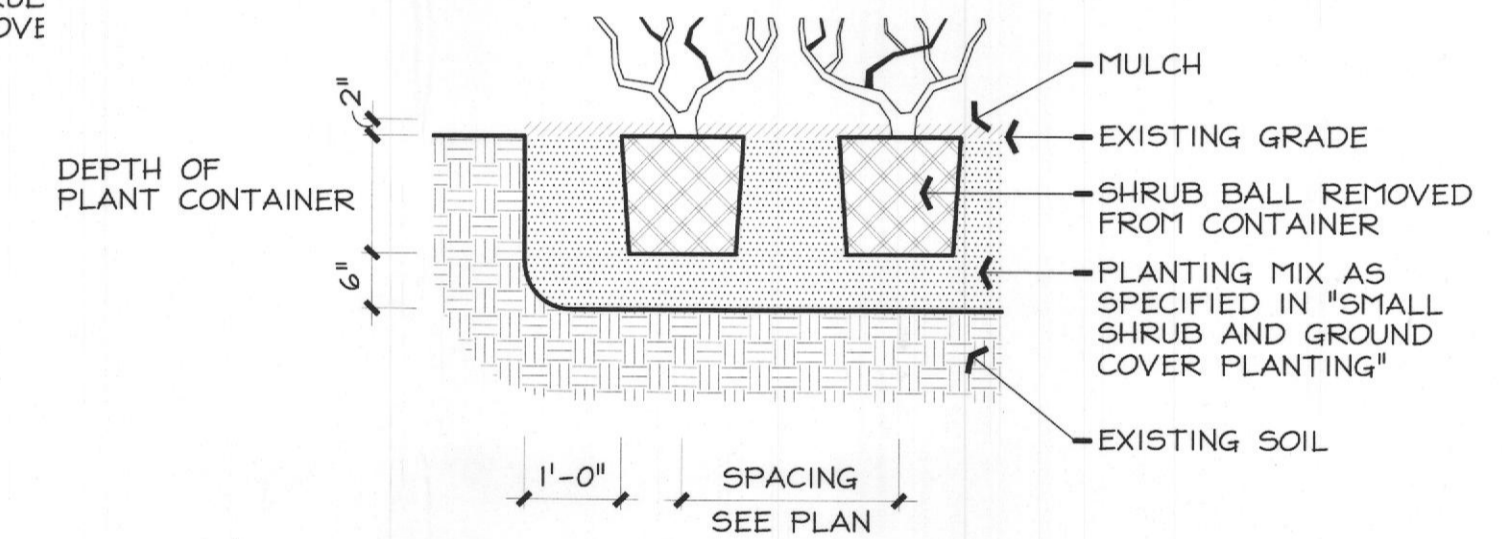

F SHRUB PLANTING - SECTION
1/2" = 1'-0"

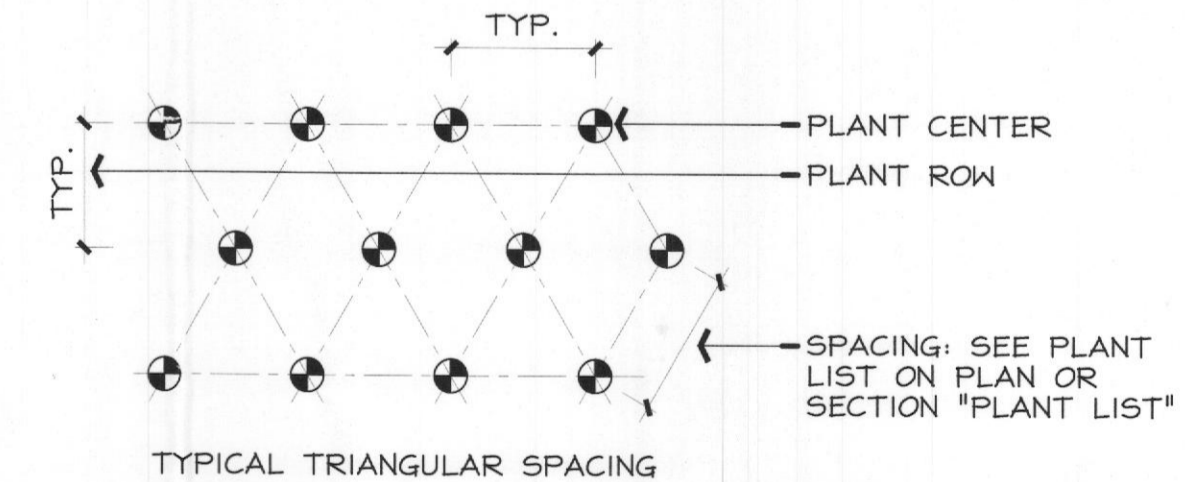

D PLANT SPACING - PLAN
1/2" = 1'-0"

LANDSCAPE PLAN SIGNATURE BLOCK

APPROVED:
I HEREBY CERTIFY THAT THE ABOVE AND FOREGOING LANDSCAPE PLAN FOR A DEVELOPMENT IN THE CITY OF ROCKWALL, TEXAS, WAS APPROVED BY THE PLANNING & ZONING COMMISSION OF THE CITY OF ROCKWALL ON THE 16 April, 2021.
WITNESS OUR HANDS, THIS 16 DAY OF April, 2021.
PLANNING & ZONING COMMISSION, CHAIRMAN
DIRECTOR OF PLANNING & ZONING

Issue Date
6 April 2021

Sheet Name
LANDSCAPE
DETAILS

Sheet Number
L12

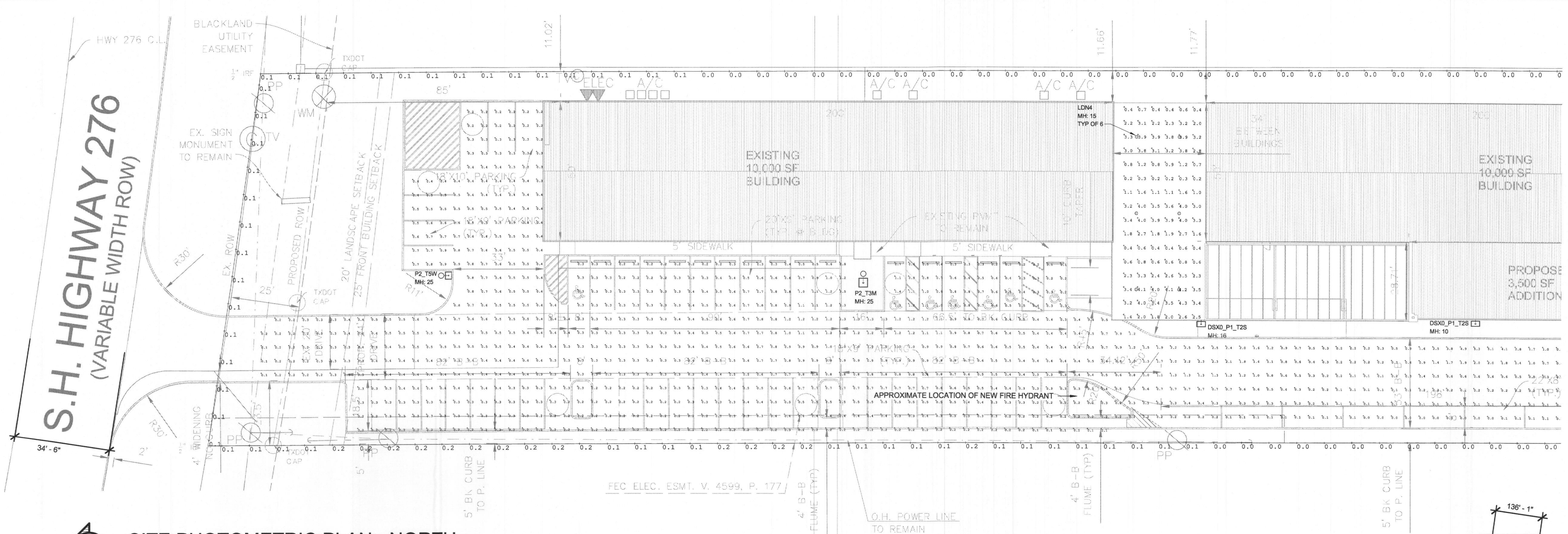

2 SITE PHOTOMETRIC PLAN - NORTH
SCALE: 1" = 20'-0" 2/E0.2

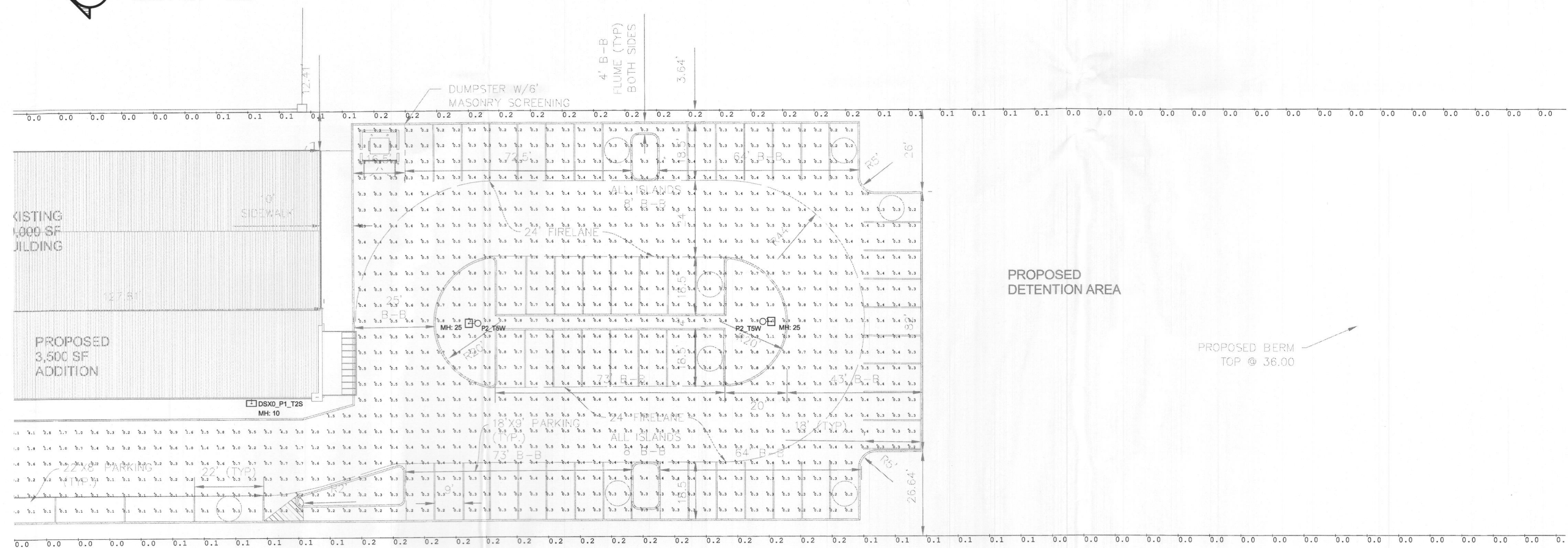

1 SITE PHOTOMETRIC PLAN - SOUTH
SCALE: 1" = 20'-0" 1/E0.2

Calculation Summary

Label	Avg	Max	Min	Avg/Min	Max/Min
Canopy	2.20	4.3	0.2	11.00	21.50
Parking	0.51	5.5	0.0	N.A.	N.A.
PropertyLineEast	0.55	0.2	0.0	N.A.	N.A.
PropertyLineNorth	0.10	0.1	1.00	1.00	1.00
PropertyLineSouth(beyond extent)	0.00	0.0	0.0	N.A.	N.A.
PropertyLineWest	0.07	0.2	0.0	N.A.	N.A.

Luminaire Schedule

Tag	Qty	Manufacturer	Description	LLF	Lum. Lumens	Lum. Watts	Total Watts
P2_T5W	3	Lithonia Lighting	DSX1 LED P2 40K T5W MVOLT	0.850	9174	70	210
P2_T2S	1	Lithonia Lighting	DSX1 LED P2 40K T2S MVOLT	0.850	8922	70	70
DSX0_P1_T2S	3	Lithonia Lighting	DSX0 LED P1 40K T2S MVOLT	0.850	4725	38	114
P2_T3M	1	Lithonia Lighting	DSX1 LED P2 40K T3M MVOLT	0.850	8640	70	70
LDN4	6	Lithonia Lighting	LDN4CYL_40_10LAR LSS	0.850	1047	10.58	63.48

NOTE: MOUNTING HEIGHT DENOTED IN FEET AT EACH LIGHT AS MH

DIMENSIONS SHOWN ON THIS PLAN ARE FOR REFERENCE ONLY

SITE INFORMATION (FOR REFERENCE ONLY)
TOTAL SITE AREA = 3.94 ACRES
FRONT SETBACK = 25 FEET
SIDE SETBACKS = 0 FEET
REAR SETBACK (NOT SHOWN, BEYOND VIEW) = 20 FEET

3 OVERALL SITE PLAN
SCALE: 1" = 160'-0" 3/E0.2

SITE PLAN SIGNATURE BLOCK
APPROVED:
I HEREBY CERTIFY THAT THE ABOVE AND FOREGOING SITE PLAN FOR A DEVELOPMENT IN THE CITY OF ROCKWALL, TEXAS, WAS APPROVED BY THE PLANNING & ZONING COMMISSION OF THE CITY OF ROCKWALL ON THE 16 April, 2021.
WITNESS OUR HANDS, THIS 16 DAY OF April, 2021.
PLANNING & ZONING COMMISSION, CHAIRMAN
DIRECTOR OF PLANNING & ZONING

Revision Schedule

Rev. #	Revision Description	Revision Date
2	E0.2	

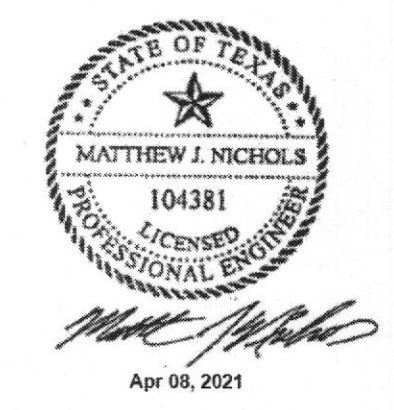

Matthew J. Nichols, P.E. (F-12818)
TX License # 104381

Matthew J. Nichols
PE

SUITE 5517 479-638-5004
1805 N 2ND ST JOB NO: 26628
ROGERS, AR 72766 DESIGNED BY: MOR

ROCKWALL FRIENDSHIP

5651 TC-276
ROYSE CITY, TX 75189

ELECTRICAL SITE PHOTOMETRIC PLAN

E0.2

CASE #: SP2021-008

2020-013-00
April 06, 2021