

CONTRACTOR TO VERIFY PLANS AND TO VISIT SITE AND NOTIFY MERSHAWN ARCHITECTS OF ANY DISCREPANCIES BEFORE CONSTRUCTION.

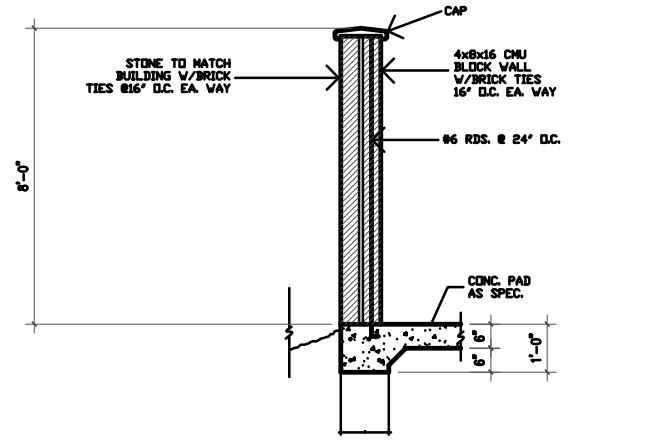

1 SECTION @ DUMPSTER WALL

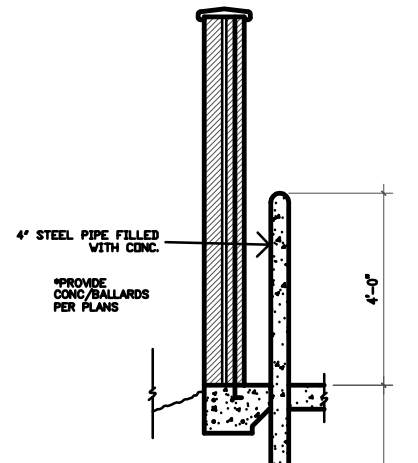

2 DETAIL @ BALLARD
NO SCALE

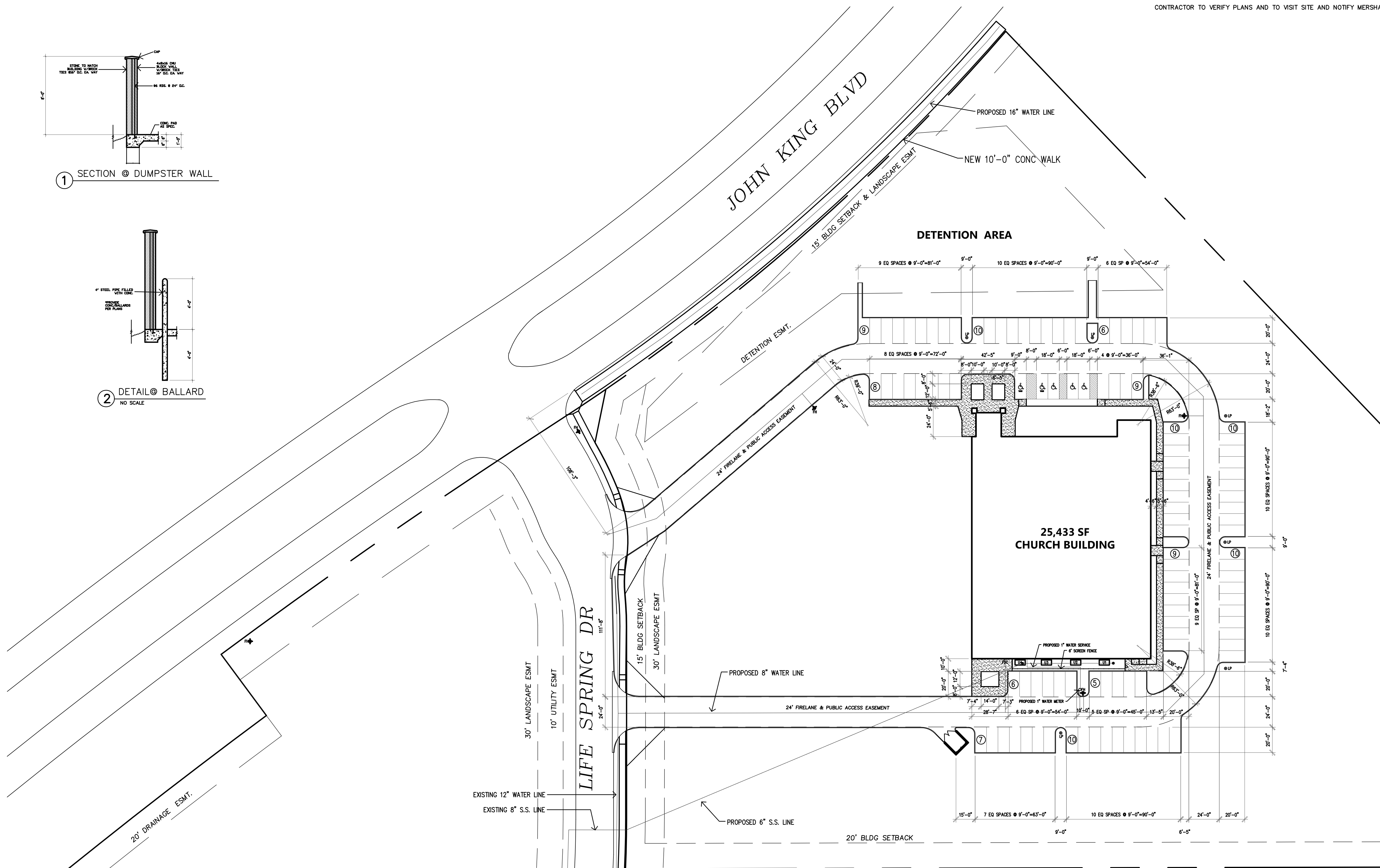

W.W. CARUTH, JR.
ADDITION
VOLUME 66 PAGE 493

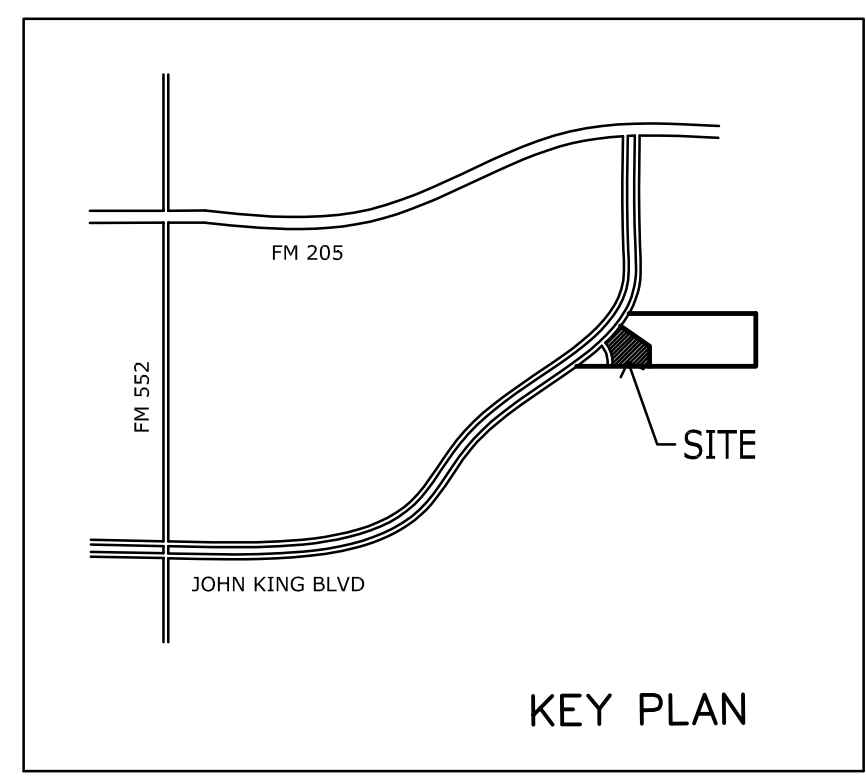

KEY PLAN

PARKING REQUIREMENTS

CHURCH 1/4 SEATS = 80
80 PARKING SPACES REQUIRED
109 PARKING SPACES PROVIDED
5 HANDICAP PARKING SPACE REQUIRED FOR PARKING OF 100-125
5 HANDICAP PARKING SPACES PROVIDED

NOTE: REFER TO CIVIL FOR ALL DIMENSIONAL CONTROLS
ALL PAVING RADII ARE 4'-6" U.N.O.
ALL PAVING DIMENSIONS ARE TO FACE OF CURB
ALL SIDEWALKS ARE 5'-0" WIDE

LIFE SPRING CHURCH
BEING A 6.99 AC. TRACT OF LAND SITUATED IN THE JOSEPH STRICKLAND SURVEY, ABST. NO. 187 IN THE CITY OF ROCKWALL, ROCKWALL COUNTY, TEXAS

OWNER
LIFE SPRING CHURCH
PASTOR REX WALKER
P.O. Box 886
ROCKWALL, TEXAS 75087
214-497-7206

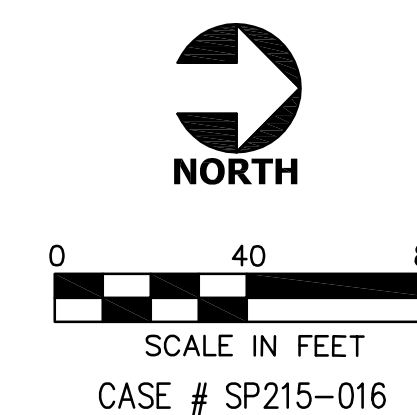

PRICING & CONSTRUCTION

GENERAL NOTES:

THESE DRAWINGS ARE DIAGRAMMATIC IN NATURE AND ARE NOT INTENDED TO INDICATE EACH AND EVERY FITTING, OFFSET, OR OTHER APPURTENANCE NECESSARY TO COMPLETE THE SYSTEM.

IT IS THE CONTRACTOR'S RESPONSIBILITY TO REVIEW THE DOCUMENTS AND INCLUDE ALL NECESSARY ITEMS TO PROVIDE A COMPLETE OPERATIONAL SYSTEM.

ANY DISCREPANCIES NOTED BY THE CONTRACTOR SHALL BE BROUGHT TO THE ATTENTIONS OF THE ARCHITECT (IN WRITING) BEFORE BIDDING THIS PROJECT.

AFTER BIDS ARE TURNED IN, THE CONTRACTOR SHALL COMPLETE THE SYSTEMS AT NO ADDITIONAL COST.

© COPYRIGHT 2011 MERSHAWN ARCHITECTS, INC.
NO PRINTING OR COPYING IS ALLOWED WITHOUT PERMISSION FROM MERSHAWN.

RESIDENTIAL RESTAURANTS
MEDICAL COMMERCIAL CHURCHES
MERSHAWN ARCHITECTS
INSTITUTIONAL ARCHITECTS
2313 RIDGE ROAD #103
ROCKWALL, TEXAS 75087
PHONE: 972-722-9302
FAX: 972-249-2051

No.	Date	Revision	By

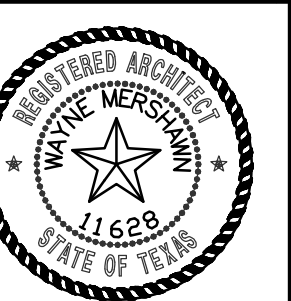

LIFE SPRING CHURCH
ROCKWALL, TEXAS
SITE PLAN

Scale:	1" = 40'-0"
Date:	MM/DD/YY
Project No.:	140311
Designed:	GW
Drawn:	GW
Checked:	WM

SHEET
A1 OF
19

CONTRACTOR TO VERIFY PLANS AND TO VISIT SITE AND NOTIFY MERSHAWN ARCHITECTS OF ANY DISCREPANCIES BEFORE CONSTRUCTION.

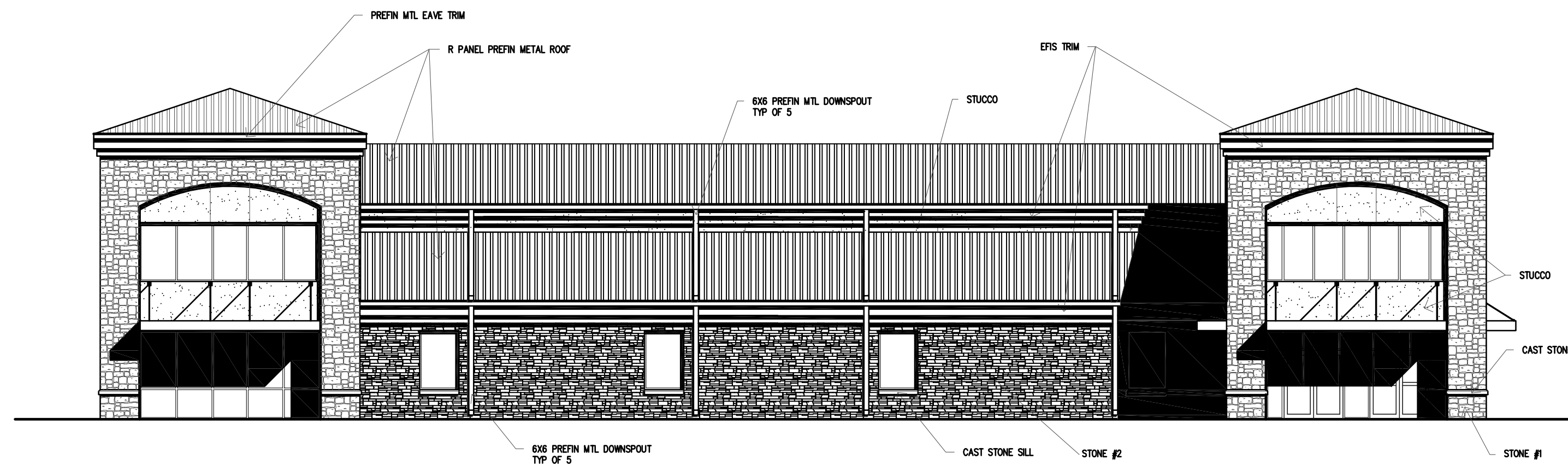

WEST ELEVATION

93% STONE MASONRY
7% EFIS TRIM

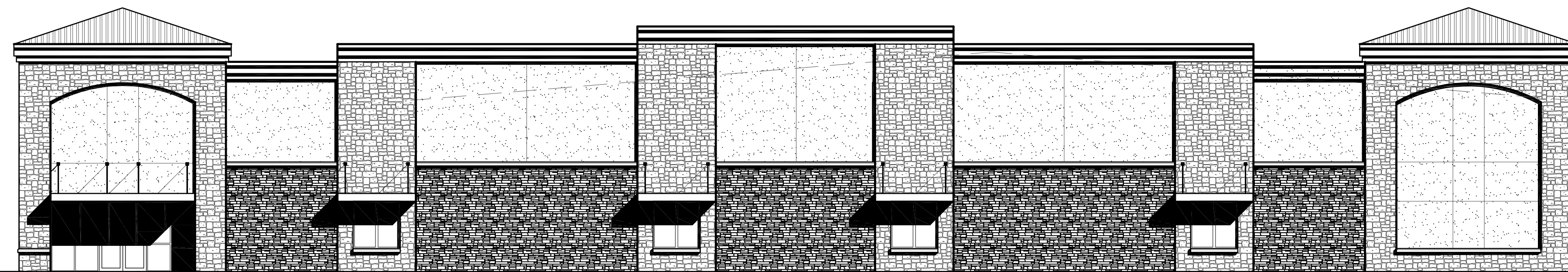

SOUTH ELEVATION

57% STONE MASONRY
37% STUCCO MASONRY
6% EFIS TRIM

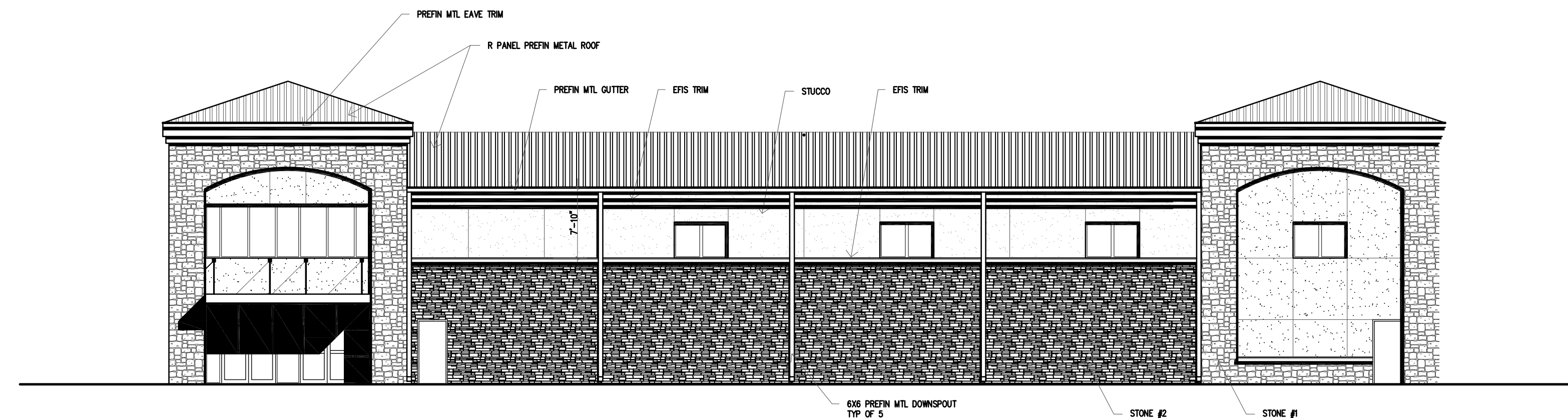

EAST ELEVATION

61% STONE MASONRY
30% STUCCO MASONRY
9% EFIS TRIM

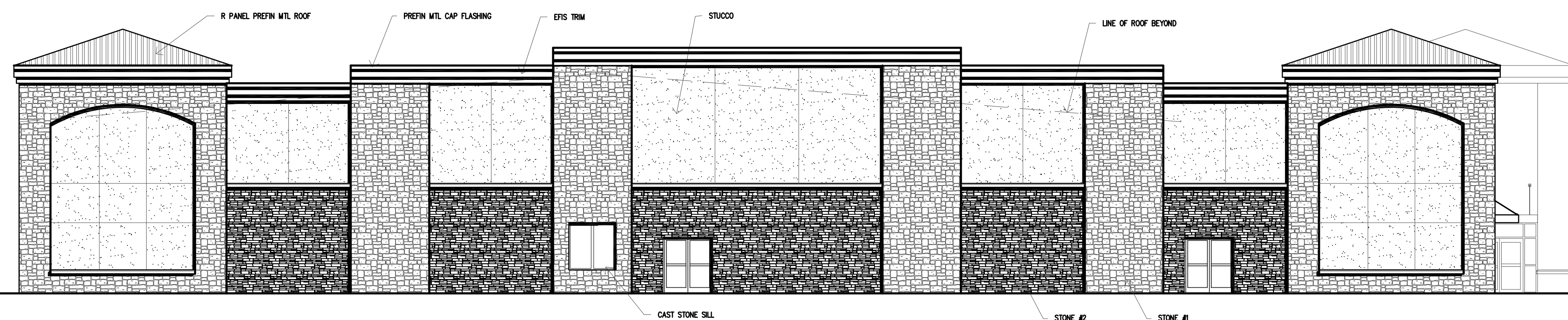

NORTH ELEVATION

53% STONE MASONRY
39% STUCCO MASONRY
8% EFIS TRIM

PRICING & CONSTRUCTION

GENERAL NOTES:

1. THESE DRAWINGS ARE DIAGRAMMATIC IN NATURE AND ARE NOT INTENDED TO INDICATE EACH AND EVERY FITTING, OFFSET, OR OTHER APPURTENANCE NECESSARY TO COMPLETE THE SYSTEM.
2. IT IS THE CONTRACTOR'S RESPONSIBILITY TO REVIEW THE DOCUMENTS AND INCLUDE ALL NECESSARY ITEMS TO PROVIDE A COMPLETE OPERATIONAL SYSTEM.
3. ANY DISCREPANCIES NOTED BY THE CONTRACTOR SHALL BE BROUGHT TO THE ATTENTIONS OF THE ARCHITECT (IN WRITING) BEFORE BIDDING THIS PROJECT.
4. AFTER BIDS ARE TURNED IN, THE CONTRACTOR SHALL COMPLETE THE SYSTEMS AT NO ADDITIONAL COST.
5. PLUMBING, MECHANICAL, AND ELECTRICAL SUBCONTRACTORS ARE RESPONSIBLE FOR COORDINATING ALL COMPONENTS TO INSURE COMPLETE AND WORKING SYSTEMS. EACH SUBCONTRACTOR SHALL REVIEW ALL DRAWINGS FOR COMPLIANCE.
6. THE ARCHITECT WILL BE RESPONSIBLE TO DETERMINE WHICH TRADE SHALL PROVIDE AND INSTALL ANY COMPONENTS MISSED FOR WORKING SYSTEMS AS NEEDED.

© COPYRIGHT 2014 MERSHAWN ARCHITECTS, INC.
NO PRINTING OR COPING IS ALLOWED
WITHOUT PERMISSION FROM MERSHAWN.

RESIDENTIAL RESTAURANTS
INSTITUTIONAL
ARCHITECTS
MERSHAWN
MEDICAL COMMERCIAL
CHURCHES
2313 RIDGE ROAD #103
ROCKWALL, TEXAS 75087
PHONE: 972-722-9302
FAX: 972-249-2051

No.	Date	Revision	By

LIFE SPRING CHURCH
ROCKWALL, TEXAS
EXTERIOR ELEVATIONS

Scale:	
Date:	MM/DD/YY
Project No.:	140311
Designed:	GW
Drawn:	GW
Checked:	WM

SHEET
A4 OF
19

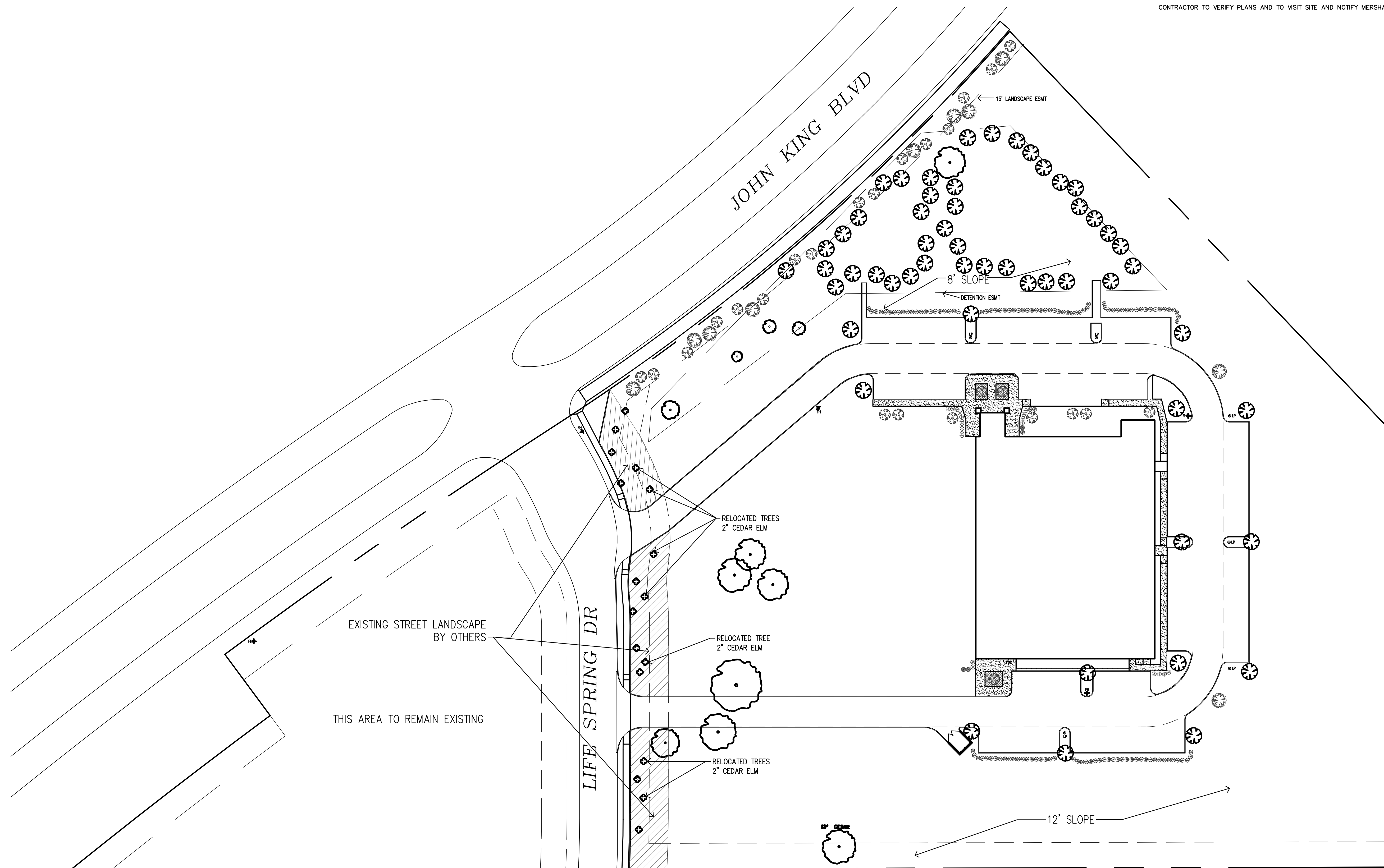

EXISTING STREET LANDSCAPE BY OTHERS

THIS AREA TO REMAIN EXISTING

INCLUDED IN ADDITION TO THE REQUIRED TREES FOR THE LANDSCAPE DESIGN IS 4 TREES TOTALING 16" OF CALIPER TO COVER THE REQUIREMENT FOR MITIGATED TREES. REFER TO L2 EXISTING TREE PLAN

GENERAL NOTES:

1. VERIFY ALL UTILITIES BEFORE CONSTRUCTION.
2. EA SUB-CONTRACTOR SHALL COORDINATE AND CALL FOR ALL INSPECTIONS W/TESTING LAB. OWNER WILL PAY FOR TESTING LABS.
3. ALL BUILDING ENTRANCES AND EXITS SHALL BE HANDICAP ACCESSIBLE. SIDEWALK AND RAMP SLOPES SHALL NOT EXCEED THE MAXIMUM REQUIRED SLOPE NOT REQUIRING HANDRAILS, SEE T&S NOTES & DETAILS.
4. LANDSCAPE SUBCONTRACTOR SHALL PROVIDE STABILIZATION OF ALL DISTURBED AREAS.
5. ALL AREAS NOT SHOWN AS SPECIFIC PLANT MATERIAL SHALL BE HYDROMULCHED BERMUDA, EXCEPT FOR UNDISTURBED SITE AREA.
6. NO TREES SHALL BE PLANTED WITHIN 5'-0" OF ANY UTILITIES.
7. NO SHRUBS SHALL BE PLANTED CLOSER THAN 4'-0" FROM CURB @ 18" DEEP PARKING SPACES

- LOT 1 BLOCK 2 OF THE JOSEPH STRICKLAND SURVEY
1. PROPOSED USE: CHURCH
 2. PROPERTY AREA: 304,687 SF OR 6.995 ACRES
 3. BUILDING AREA: 26,433 SF
 4. BUILDING HEIGHT: SINGLE STORY - 33'-7 1/2"
 5. LOT COVERAGE: 8.35%
F.A.R. = 0.0811
 6. PARKING REQUIRED: 320 SEATS @ 1 SPACE PER 4 = 80
80 SPACES REQUIRED
 7. HANDICAP REQUIRED 5 ACCESSIBLE FOR 100-125 SPACES = 5 ACCESSIBLE
 8. TOTAL PARKING PROVIDED: 109 SPACES
 9. LANDSCAPE AREA REQUIRED: 45,703 SF
LANDSCAPE AREA PROVIDED: 229,364 SF
 10. TOTAL SQUARE FOOTAGE OF IMPERVIOUS SURFACE: 75,323 SF

- EXISTING CEDAR TO REMAIN
- RED BUD (26)
4" HIGH @ INSTALLATION
- BURR OAK (10)
4" MIN. CALIPER
- LIVE OAK (56)
4" MIN. CALIPER
- ASIAN JASMINE
PLANTS SHALL BE A MINIMUM OF 6" TALL @ PLANTING SHALL BE PLANTED @ 18" O.C.
- INDIAN HAWTHORNE (116)
PLANTS SHALL BE A MINIMUM OF 30" TALL @ PLANTING SHALL BE PLANTED @ 36" O.C.
- BOXWOOD BUSH (25)
PLANTS SHALL BE A MINIMUM OF 30" TALL @ PLANTING, SHALL BE PLANTED @ 36" O.C.

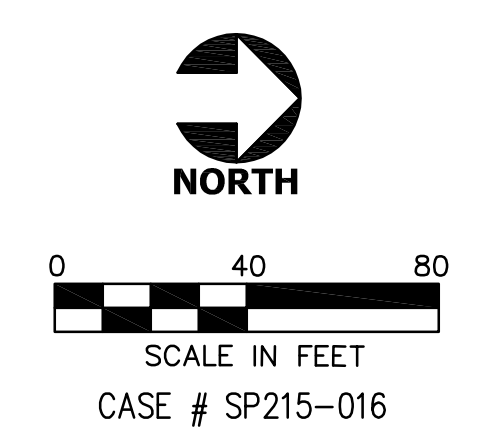

PRICING & CONSTRUCTION GENERAL NOTES:

THESE DRAWINGS ARE DIAGRAMMATIC IN NATURE AND ARE NOT INTENDED TO INDICATE EACH AND EVERY FITTING, OFFSET, OR OTHER APPURTENANCE NECESSARY TO COMPLETE THE SYSTEM.

IT IS THE CONTRACTOR'S RESPONSIBILITY TO REVIEW THE DOCUMENTS AND INCLUDE ALL NECESSARY ITEMS TO PROVIDE A COMPLETE OPERATIONAL SYSTEM.

ANY DISCREPANCIES NOTED BY THE CONTRACTOR SHALL BE BROUGHT TO THE ATTENTIONS OF THE ARCHITECT (IN WRITING) BEFORE BIDDING THIS PROJECT.

AFTER BIDS ARE TURNED IN, THE CONTRACTOR SHALL COMPLETE THE SYSTEMS AT NO ADDITIONAL COST.

© COPYRIGHT 2011 MERSHAWN ARCHITECTS, INC.
NO PRINTING OR COPING IS ALLOWED WITHOUT PERMISSION FROM MERSHAWN.

RESIDENTIAL RESTAURANTS
INSTITUTIONAL
ARCHITECTS

MEDICAL COMMERCIAL
CHURCHES
MERSHAWN

2313 RIDGE ROAD #103
ROCKWALL, TEXAS 75087

PHONE: 972-722-9302
FAX: 972-249-2051

No.	Date	Revision	By

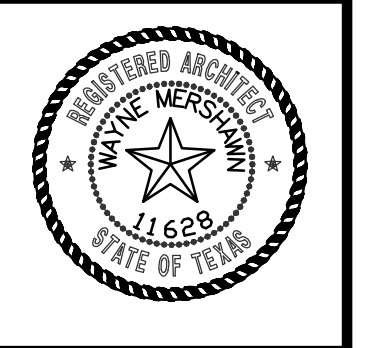

LIFE SPRING CHURCH
ROCKWALL, TEXAS

LANDSCAPE PLAN

Scale: 1" = 40'-0"

Date: MM/DD/YY

Project No.: 140311

Designed: GW

Drawn: GW

Checked: WM

CONTRACTOR TO VERIFY PLANS AND TO VISIT SITE AND NOTIFY MERSHAWN ARCHITECTS OF ANY DISCREPANCIES BEFORE CONSTRUCTION.

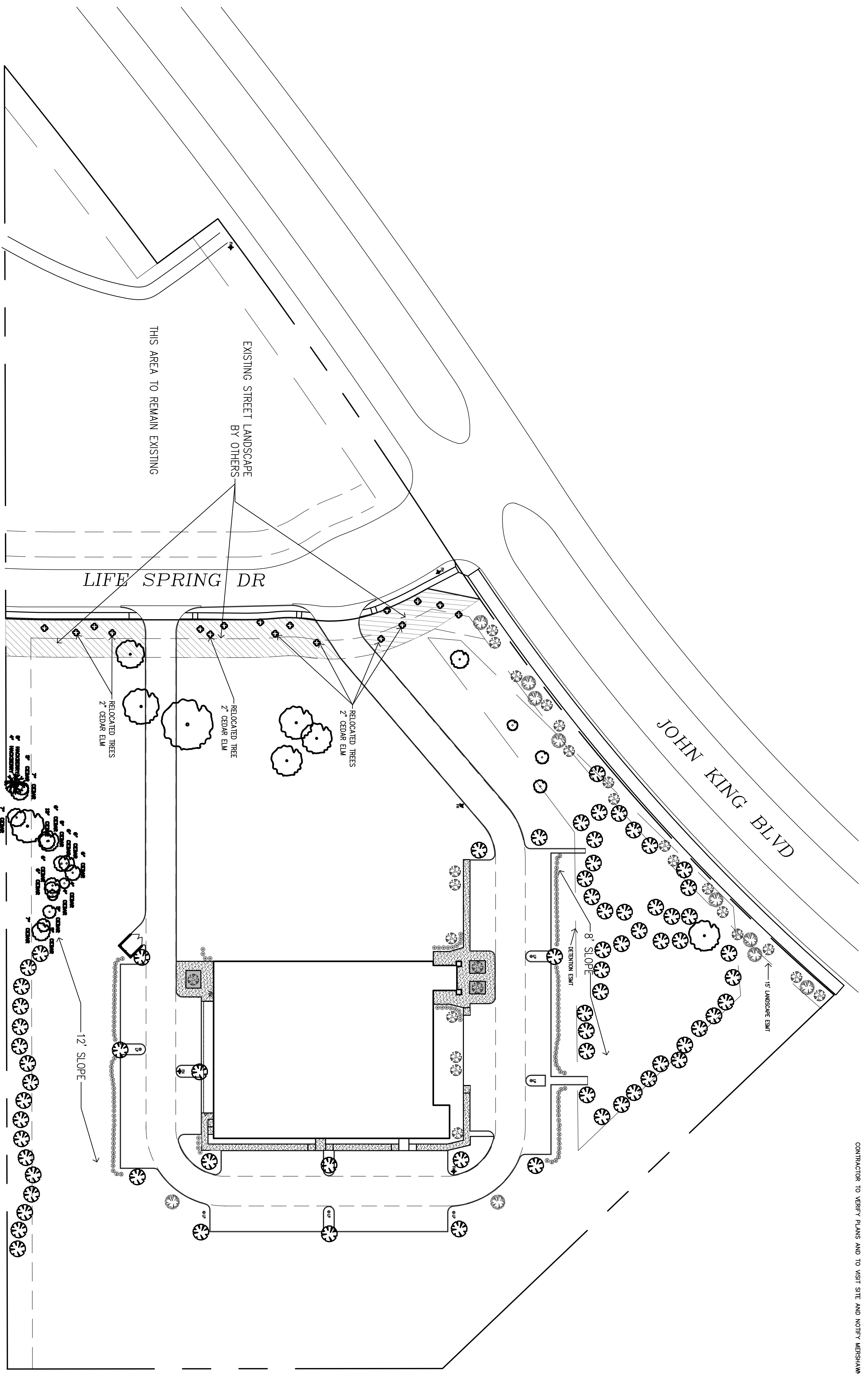

GENERAL NOTES:

1. VERIFY ALL UTILITIES BEFORE CONSTRUCTION.
2. E.A. SUBCONTRACTOR SHALL COORDINATE AND CALL FOR ALL UTILITIES.
3. ALL BUILDING ENTRANCES AND EXITS SHALL BE HANDICAP ACCESSIBLE. SIDEWALK AND RAMP SLOPES SHALL NOT EXCEED THE MAXIMUM REQUIRED SLOPE NOT REQUIRING HANDRAILS. SEE LANDSCAPE SUBCONTRACTOR SHALL PROVIDE STABILIZATION OF ALL DISTURBED AREAS.
4. ALL AREAS NOT SHOWN AS SPECIFIC PLANT MATERIAL SHALL BE HYDROMULCHED BERMUDA, EXCEPT FOR UNDISTURBED SITE AREA.
5. NO TREES SHALL BE PLANTED WITHIN 5'-0" OF ANY UTILITIES.
6. NO SHRUBS SHALL BE PLANTED CLOSER THAN 4'-0" FROM CURB.
7. 18" DEEP PARKING SPACES.

INCLUDED IN ADDITION TO THE REQUIRED TREES FOR THE LANDSCAPE DESIGN IS 4 TREES TOTALING 16" OF CALIPER TO COVER THE REQUIREMENT FOR MITIGATED TREES. REFER TO L2 EXISTING TREE PLAN

- LOT 1 BLOCK 2 OF THE JOSEPH STRICKLAND SURVEY
1. PROPOSED USE - CHURCH
 2. PROPERTY AREA - 30,487 SF OR 6,995 ACRES
 3. BUILDING HEIGHT - SINGLE STORY - 33'-7 1/2"
 4. LOT COVERAGE - 8.33%
 5. PARKING REQUIRED - 220 SEATS @ 1 SPACE PER 4 = 80
 6. TOTAL PARKING PROVIDED - 109 SPACES
 7. LANDSCAPE AREA REQUIRED - 45,703 SF
 8. TOTAL SQUARE FOOTAGE OF IMPERVIOUS SURFACE - 75,323 SF

	EXISTING CEDAR TO REMAIN
	RED BUD (26)
	4" HIGH @ INSTALLATION
	BURR OAK (10)
	4" MIN. CALIPER
	LIVE OAK (12)
	4" MIN. CALIPER
	ASIAN YASUANE
	PLANTS SHALL BE A MINIMUM OF 30" TALL @ PLANTING
	IRIGAN YASUANE (11)
	SHALL BE PLANTED @ 35" O.C.
	BOXWOOD BUSH (29)
	MINIMUM OF 30" TALL @ PLANTING SHALL BE PLANTED @ 35" O.C.

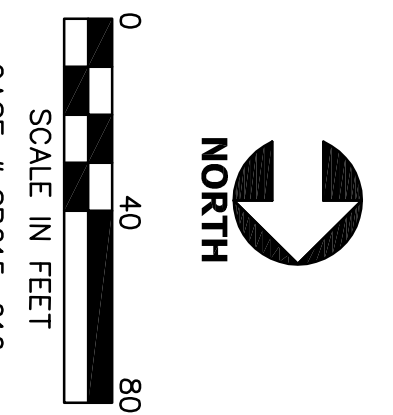

PRICING & CONSTRUCTION

GENERAL NOTES:

THESE DRAWINGS ARE DIAGRAMATIC IN NATURE AND ARE NOT INTENDED TO INDICATE EXACT AND EXACT FITTING. CONTRACTOR SHALL BE RESPONSIBLE FOR NECESSARY TO COMPLETE THE SYSTEM.

IT IS THE CONTRACTOR'S RESPONSIBILITY TO VERIFY ALL UTILITIES AND TO PROVIDE A COMPLETE OPERATIONAL SYSTEM.

ANY DISCREPANCIES NOTED BY THE CONTRACTOR SHALL BE BROUGHT TO THE ATTENTION OF THE ARCHITECT (IN WRITING) BEFORE BIDDING THIS PROJECT.

AFTER BIDS ARE TURNED IN, THE CONTRACTOR SHALL COMPLETE THE SYSTEMS AT NO ADDITIONAL COST.

© COPYRIGHT 2011 MERSHAWN ARCHITECTS, INC. NO PRINTING OR COPYING IS ALLOWED WITHOUT PERMISSION FROM MERSHAWN.

<p>LIFE SPRING CHURCH ROCKWALL, TEXAS</p> <p>LANDSCAPE PLAN</p>		No.	Date	Revision	By

Scale: 1" = 40'-0"

Date: MM/DD/YY

Project No.: 140311

Designed: CW

Drawn: CW

Checked: MW

SHEET **L1** OF **2**

MEDICAL COMMERCIAL CHURCHES

MERSHAWN ARCHITECTS

2313 RIDGE ROAD #103
ROCKWALL, TEXAS 75087

RESIDENTIAL RESTAURANTS INSTITUTIONAL

ARCHITECTS

PHONE: 972-722-9302
FAX: 972-249-2081

STATISTICS						
Description	Symbol	Avg	Max	Min	Max/Min	Avg/Min
Calc Zone #1	+	1.1 fc	3.9 fc	0.0 fc	N/A	N/A

NOTES

1. FIXTURES MOUNTED ON 17.5' POLE WITH 2.5' BASE FOR AN 20.0' OAH

LUMINAIRE SCHEDULE								
Symbol	Label	Qty	Catalog Number	Description	Lamp	Lumens	LLF	Watts
□ +	A	7	KAD LED 40C 1000 40K R4 MVOLT	KAD LED, 40 LED, 1 AMP MVOLT DRIVER, 4000K, TYPE 4 OPTICS.	LED	Absolute	0.95	140



Plan View
Scale: 1" = 40'

Layout by:
MILLER
Date
Jul 6 2015
Scale
Drawing No.