



2025 DEVELOPMENT APPLICATION SCHEDULE

City of Rockwall • 385 South Goliad Street • Rockwall, Texas 75087
 Planning and Zoning Department • Phone: (972) 771-7745 • Email: Planning@Rockwall.com

| Submittal Date (5:00 PM) ^{6 & 7} | ARB Meeting (5:00 PM) ¹ P&Z Work Session (6:00 PM) ² | Corrected Plans (3:00 PM) Parks Board Meeting (6:00 PM) ³ | ARB Meeting (5:00 PM) ¹ P&Z Meeting (6:00 PM) | Engineering Submittal Date (5:00 PM) | City Council Meeting ⁴ at 6:00 PM | |
|--|---|---|---|--|--|--------------------------------------|
| | | | | | 1 st Reading | 2 nd Reading ⁵ |
| January 17, 2025 | January 28, 2025 | February 4, 2025 | February 11, 2025 | January 29, 2025 February 12, 2025 | <i>February 18, 2025</i> | March 3, 2025 |
| February 14, 2025 | February 25, 2025 | March 4, 2025 | March 11, 2025 | February 26, 2025 March 12, 2025 | March 17, 2025 | April 7, 2025 |
| March 14, 2025 | March 25, 2025 | April 1, 2025 | April 15, 2025 | March 26, 2025 April 16, 2025 | April 21, 2025 | May 5, 2025 |
| April 17, 2025 | April 29, 2025 | May 6, 2025 | May 13, 2025 | April 30, 2025 May 14, 2025 | May 19, 2025 | June 2, 2025 |
| May 16, 2025 | May 27, 2025 | June 3, 2025 | June 10, 2025 | May 28, 2025 June 11, 2025 | June 16, 2025 | July 7, 2025 |
| June 13, 2025 | June 24, 2025 | July 1, 2025 | July 15, 2025 | June 25, 2025 July 16, 2025 | July 21, 2025 | August 4, 2025 |
| July 18, 2025 | July 29, 2025 | August 5, 2025 | August 12, 2025 | July 30, 2025 August 13, 2025 | August 18, 2025 | <i>September 2, 2025</i> |
| August 15, 2025 | August 26, 2025 | <i>September 3, 2025</i> | September 9, 2025 | August 27, 2025 September 10, 2025 | September 15, 2025 | October 6, 2025 |
| September 12, 2025 | September 30, 2025 | October 7, 2025 | October 14, 2025 | October 1, 2025 October 15, 2025 | October 20, 2025 | November 3, 2025 |
| October 17, 2025 | October 28, 2025 | November 4, 2025 | November 11, 2025 | October 29, 2025 November 12, 2025 | November 17, 2025 | December 1, 2025 |
| <i>NO SUBMITTAL DATE IN NOVEMBER. DEVELOPMENT APPLICATIONS CAN BE SUBMITTED, BUT WILL NOT BE PROCESSED UNTIL THE DECEMBER 12, 2025 SUBMITTAL DATE.</i> | | | | November 26, 2025 December 10, 2025 | December 15, 2025 | January 5, 2026 |
| December 12, 2025 | <i>NO WORKSESSION MEETING⁸</i> | January 6, 2026 | January 13, 2026 | December 31, 2025 January 14, 2026 | <i>January 20, 2026</i> | February 2, 2026 |
| January 16, 2026 | January 27, 2026 | February 3, 2026 | February 10, 2026 | January 28, 2026 February 11, 2026 | <i>February 17, 2026</i> | March 2, 2026 |

P&Z: Planning and Zoning Commission • ARB: Architectural Review Committee • RED: City Council Meeting on a Tuesday • BLUE: Parks Board on Wednesday

NOTES:

- The Architectural Review Board (ARB) reviews site plans and building elevations for projects located within any zoning district. Your project architect is **HIGHLY** encouraged to attend this meeting. **STAFF WILL CONTACT YOU SHOULD YOUR PROJECT NOT REQUIRE AN ARB MEETING.**
- All projects will be reviewed by the Planning & Zoning Commission during the scheduled work session. Applicants will be expected to be in attendance and present their case to the Planning and Zoning Commission during this meeting.
- Residential Plats are subject to review by the Parks Board. If Parks Board review is necessary, you are required to attend the meeting. Contact the Director of Parks and Recreation at (972) 772-6467 after the submission of a preliminary and/or final plat to discuss parkland issues and verify meeting dates. Applicants are required to be in attendance at the Park Board meeting.
- City Council reviews all Plats, Zoning, Specific Use Permit, and/or Planned Development District applications.
- Zoning, Specific Use Permits and Planned Development Districts require a second reading of the ordinance prior to final approval/adoption.
- If plans are not resubmitted by 3:00 PM on this date your case will be denied administratively, and you will be required to resubmit a new development application and fee on the next available submittal date.
- Early and late submittals will NOT be accepted. This means that you will need to submit on the submittal date.
- Since there is no Work Session Meeting associated with the December Submittal Date, staff recommends that requests for zoning changes wait to be submitted until the January 16, 2026 Submittal Date.

NOTE: Minor Plats, Amending Plats, and Administrative Site Plans can be approved by staff if it is permitted by Chapter 38, Subdivisions, of the Municipal Code of Ordinances. Please contact staff to discuss requirements and procedures for administrative approval.



PRE-APPLICATION MEETING REQUEST

City of Rockwall
Planning and Zoning Department
385 S. Goliad Street
Rockwall, Texas 75087

| | |
|-----------------------|----------------------|
| STAFF USE ONLY | |
| MEETING DATE: | <input type="text"/> |
| MEETING TIME: | <input type="text"/> |

PRE-APPLICATION MEETING INFORMATION

A Pre-Application Meeting is strongly recommended (*and in certain circumstances required*) prior to submittal of a development application. These meetings are held on Thursday morning's beginning at 9:00 AM, by appointment. Representatives from Engineering, Planning, Fire, Police, Parks, and Building Departments attend the meeting in an effort to assist you with your project by answering any questions you may have and explaining the development process and timelines.

Due to the number of requests for Pre-Application meetings that are received, staff cannot guarantee an appointment at the next scheduled meeting. We recommend requesting an appointment a minimum of one (1) week in advance. To best facilitate discussion during the meeting, include all conceptual drawings, site plans or other schematics with your completed request. For assistance with this form or other questions, please contact the Planning Department at (972) 771-7745 or at planning@rockwall.com.

I acknowledge that a conceptual drawing or site plan must be submitted as part of this request. Appointments may not be scheduled for requests without conceptual plans.

Initial Above

I acknowledge that neither submission of this request, nor the Pre-Application meeting, constitutes a permit or confers any permit rights under Chapter 245 of the Texas Local Government Code.

Initial Above

PROPERTY AND PROJECT INFORMATION [PLEASE PRINT]

Address

General Location

Proposed Use Proposed Square Footage

Are you proposing any alcohol sales? Yes No

Do you intend to subdivide or combine the property with other parcels? Yes No

Is the project expected to exceed \$50,000 in cost? Yes No

APPLICANT INFORMATION [PLEASE PRINT]

Applicant

Address

City State Zip

Phone Email

RESOURCES FOR YOU

- For applications, checklists, departmental contacts, demographics and more, visit our website: <http://www.rockwall.com/planning>
- For GIS information for due diligence research, including downloadable and interactive maps (for zoning, parcel information, etc.), visit our GIS website: <http://www.rockwall.com/gis>



DEVELOPMENT APPLICATION

City of Rockwall
Planning and Zoning Department
385 S. Goliad Street
Rockwall, Texas 75087

STAFF USE ONLY

PLANNING & ZONING CASE NO. _____

NOTE: THE APPLICATION IS NOT CONSIDERED ACCEPTED BY THE CITY UNTIL THE PLANNING DIRECTOR AND CITY ENGINEER HAVE SIGNED BELOW.

DIRECTOR OF PLANNING: _____

CITY ENGINEER: _____

PLEASE CHECK THE APPROPRIATE BOX BELOW TO INDICATE THE TYPE OF DEVELOPMENT REQUEST [SELECT ONLY ONE BOX]:

PLATTING APPLICATION FEES:

- MASTER PLAT (\$100.00 + \$15.00 ACRE) ¹
- PRELIMINARY PLAT (\$200.00 + \$15.00 ACRE) ¹
- FINAL PLAT (\$300.00 + \$20.00 ACRE) ¹
- REPLAT (\$300.00 + \$20.00 ACRE) ¹
- AMENDING OR MINOR PLAT (\$150.00)
- PLAT REINSTATEMENT REQUEST (\$100.00)

SITE PLAN APPLICATION FEES:

- SITE PLAN (\$250.00 + \$20.00 ACRE) ¹
- AMENDED SITE PLAN/ELEVATIONS/LANDSCAPING PLAN (\$100.00)

ZONING APPLICATION FEES:

- ZONING CHANGE (\$200.00 + \$15.00 ACRE) ¹
- SPECIFIC USE PERMIT (\$200.00 + \$15.00 ACRE) ^{1&2}
- PD DEVELOPMENT PLANS (\$200.00 + \$15.00 ACRE) ¹

OTHER APPLICATION FEES:

- TREE REMOVAL (\$75.00)
- VARIANCE REQUEST/SPECIAL EXCEPTIONS (\$100.00) ²

NOTES:

¹: IN DETERMINING THE FEE, PLEASE USE THE EXACT ACREAGE WHEN MULTIPLYING BY THE PER ACRE AMOUNT. FOR REQUESTS ON LESS THAN ONE ACRE, ROUND UP TO ONE (1) ACRE.

²: A **\$1,000.00** FEE WILL BE ADDED TO THE APPLICATION FEE FOR ANY REQUEST THAT INVOLVES CONSTRUCTION WITHOUT OR NOT IN COMPLIANCE TO AN APPROVED BUILDING PERMIT.

PROPERTY INFORMATION [PLEASE PRINT]

ADDRESS _____

SUBDIVISION _____

LOT _____

BLOCK _____

GENERAL LOCATION _____

ZONING, SITE PLAN AND PLATTING INFORMATION [PLEASE PRINT]

CURRENT ZONING _____

CURRENT USE _____

PROPOSED ZONING _____

PROPOSED USE _____

ACREAGE _____

LOTS [CURRENT] _____

LOTS [PROPOSED] _____

- SITE PLANS AND PLATS:** BY CHECKING THIS BOX YOU ACKNOWLEDGE THAT DUE TO THE PASSAGE OF HB3167 THE CITY NO LONGER HAS FLEXIBILITY WITH REGARD TO ITS APPROVAL PROCESS, AND FAILURE TO ADDRESS ANY OF STAFF'S COMMENTS BY THE DATE PROVIDED ON THE DEVELOPMENT CALENDAR WILL RESULT IN THE DENIAL OF YOUR CASE.

OWNER/APPLICANT/AGENT INFORMATION [PLEASE PRINT/CHECK THE PRIMARY CONTACT/ORIGINAL SIGNATURES ARE REQUIRED]

OWNER

APPLICANT

CONTACT PERSON _____

CONTACT PERSON _____

ADDRESS _____

ADDRESS _____

CITY, STATE & ZIP _____

CITY, STATE & ZIP _____

PHONE _____

PHONE _____

E-MAIL _____

E-MAIL _____

NOTARY VERIFICATION [REQUIRED]

BEFORE ME, THE UNDERSIGNED AUTHORITY, ON THIS DAY PERSONALLY APPEARED _____ [OWNER] THE UNDERSIGNED, WHO STATED THE INFORMATION ON THIS APPLICATION TO BE TRUE AND CERTIFIED THE FOLLOWING:

"I HEREBY CERTIFY THAT I AM THE OWNER FOR THE PURPOSE OF THIS APPLICATION; ALL INFORMATION SUBMITTED HEREIN IS TRUE AND CORRECT; AND THE APPLICATION FEE OF \$ _____, TO COVER THE COST OF THIS APPLICATION, HAS BEEN PAID TO THE CITY OF ROCKWALL ON THIS THE _____ DAY OF _____, 20 _____. BY SIGNING THIS APPLICATION, I AGREE THAT THE CITY OF ROCKWALL (I.E. "CITY") IS AUTHORIZED AND PERMITTED TO PROVIDE INFORMATION CONTAINED WITHIN THIS APPLICATION TO THE PUBLIC. THE CITY IS ALSO AUTHORIZED AND PERMITTED TO REPRODUCE ANY COPYRIGHTED INFORMATION SUBMITTED IN CONJUNCTION WITH THIS APPLICATION, IF SUCH REPRODUCTION IS ASSOCIATED OR IN RESPONSE TO A REQUEST FOR PUBLIC INFORMATION."

GIVEN UNDER MY HAND AND SEAL OF OFFICE ON THIS THE _____ DAY OF _____, 20 ____.

OWNER'S SIGNATURE _____

NOTARY PUBLIC IN AND FOR THE STATE OF TEXAS _____

MY COMMISSION EXPIRES _____



DEVELOPMENT APPLICATION SUBMITTAL REQUIREMENTS

City of Rockwall
Planning and Zoning Department
385 S. Goliad Street
Rockwall, Texas 75087

PLATTING APPLICATION SUBMITTAL REQUIREMENTS [ALL PLAT TYPES]

- PLAT TYPE.
 - MINOR/AMENDING PLAT.
 - MASTER PLAT.
 - PRELIMINARY PLAT.
 - FINAL PLAT.
 - REPLAT.
 - VACATION PLAT.

Staff requires two (2), 18" x 24" copies be submitted at the time the application is submitted. See *Folding Requirements* in this development packet.

- DIGITAL COPY OF THE PLAT. The following is required with all plat submittals:
 - ONE (1) PDF COPY OF THE PLAT
 - ONE (1) SURVEY BOUNDARY CLOSURE REPORT.

* AFTER APPROVAL STAFF WILL REQUIRE ONE (1) AUTOCAD/ESRI (DWG, DXF, OR SHP FILE FORMAT) FILE

- TREESCAPE PLAN [IF APPLICABLE].
- LANDSCAPE PLAN [IF APPLICABLE].
- APPLICATION AND APPLICATION FEE.

SITE PLAN APPLICATION SUBMITTAL REQUIREMENTS

- PLAN SET. A plan set is composed of the following items (failure to submit all of the items required shall constitute an incomplete application):
 - SITE PLAN.
 - LANDSCAPE PLAN.
 - TREESCAPE PLAN.
 - PHOTOMETRIC PLAN.
 - BUILDING ELEVATIONS.

Staff requires the submittal of two (2) complete plan sets and one (1) digital copy in .pdf format with a site plan application. All sheets submitted to staff shall be 24" x 36", arranged into sets, and be folded to a 9" x 12" *Tri-Fold* with the project title or identifier facing out.

- PHYSICAL BUILDING MATERIAL SAMPLE BOARD (11" x 17"). See the *Material Sample Board Design Guidelines* in this development packet. Individual material samples or sample boards that are larger than 11" x 17" will not be accepted.
- VARIANCE REQUEST LETTER. The letter must indicate the variance being requested, the reason for the variance, and the two (2) required compensatory measures being offered to off-set the variance in accordance with the requirements of the UDC.
- APPLICATION AND APPLICATION FEE.

ZONING CHANGE APPLICATION SUBMITTAL REQUIREMENTS

- LEGAL DESCRIPTION. A legal description consists of written words that delineate a specific piece of real property. A legal description may be a metes and bounds description or, if the property is platted, a copy of the plat may be submitted to verify the lot and block survey system.
- ZONING EXHIBIT OR CONCEPT PLAN. A zoning exhibit is generally a survey, plat, concept plan or other visual description of the property [Specific Use Permit (SUP) exhibits can be a site plan or building elevations; check with staff for prior to submitting an application for what is appropriate]. Staff requires two (2), 24" x 36" copies and one digital copy (PDF preferred) be submitted at the time the application is submitted. All submittals should be folded individually so that the project title or identifier is facing out. *In order to reduce the applicant's costs and to conserve paper, staff may accept other sheet sizes for a submittal if an appropriate scale and level of detail is maintained. Check with staff prior to submitting a small or larger drawing size.*
- LETTER OF EXPLANATION. A letter from the applicant or property owner explaining the purpose of the zoning application.
- APPLICATION AND APPLICATION FEE.

IT IS IMPORTANT TO YOU AS AN APPLICANT TO RETURN A FULLY COMPLETED APPLICATION PACKAGE. INCOMPLETE APPLICATION PACKAGES WILL NOT BE ACCEPTED BY STAFF AND WILL BE RETURNED TO APPLICANTS. DUE TO THE PASSAGE OF HB3167, APPLICATIONS AND APPLICATION PACKAGES WILL ONLY BE ACCEPTED ON THE SUBMITTAL DATE AND EARLY AND/OR LATE APPLICATIONS WILL BE RETURNED.



FOLDING REQUIREMENTS

City of Rockwall
Planning and Zoning Department
385 S. Goliad Street
Rockwall, Texas 75087

FOLDING REQUIREMENTS FOR PLANS THAT ARE 24" X 36"

All plan sets that are 24" x 36" that are submitted to the City of Rockwall shall be folded in the following manner:

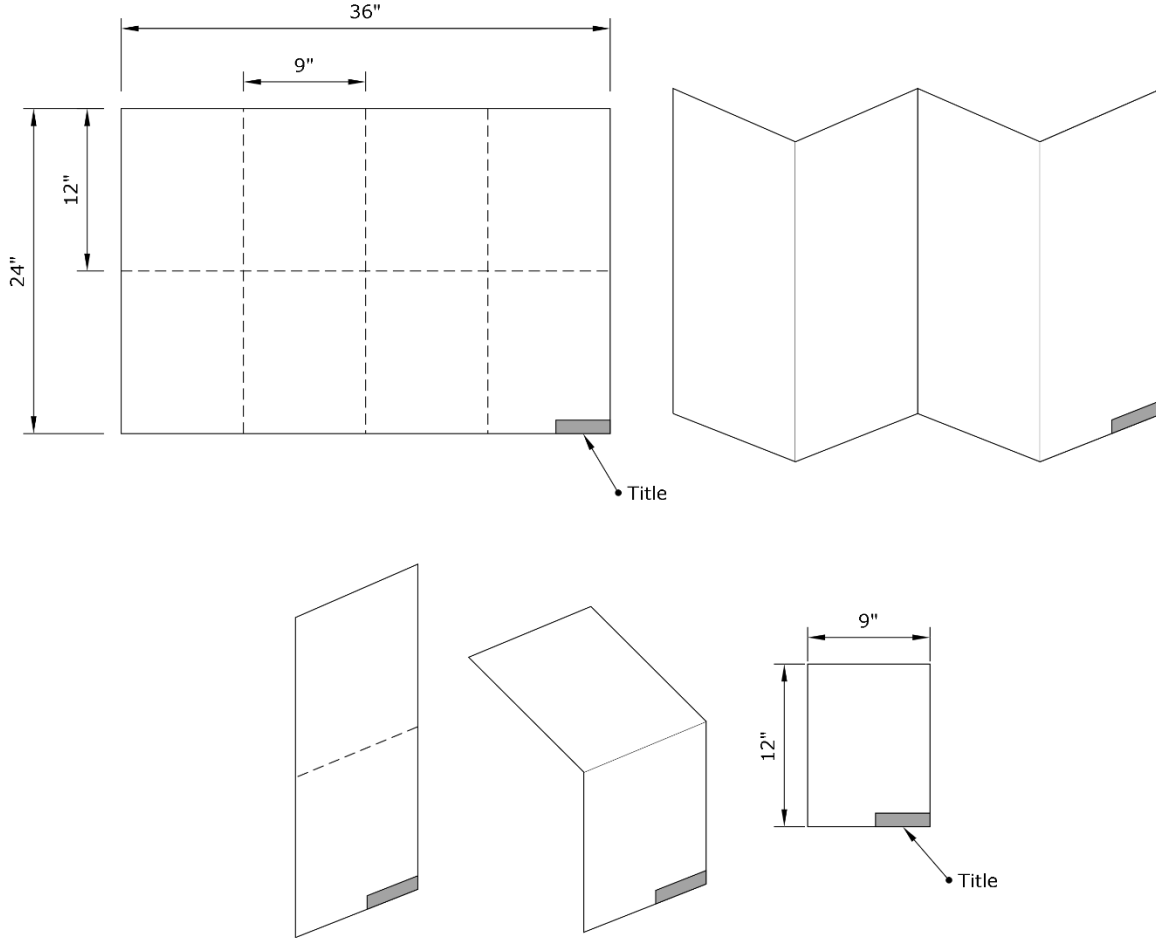

FOLDING REQUIREMENTS FOR PLANS THAT ARE 18" X 24"

All plan sets that are 18" x 24" that are submitted to the City of Rockwall shall be folded in the following manner:

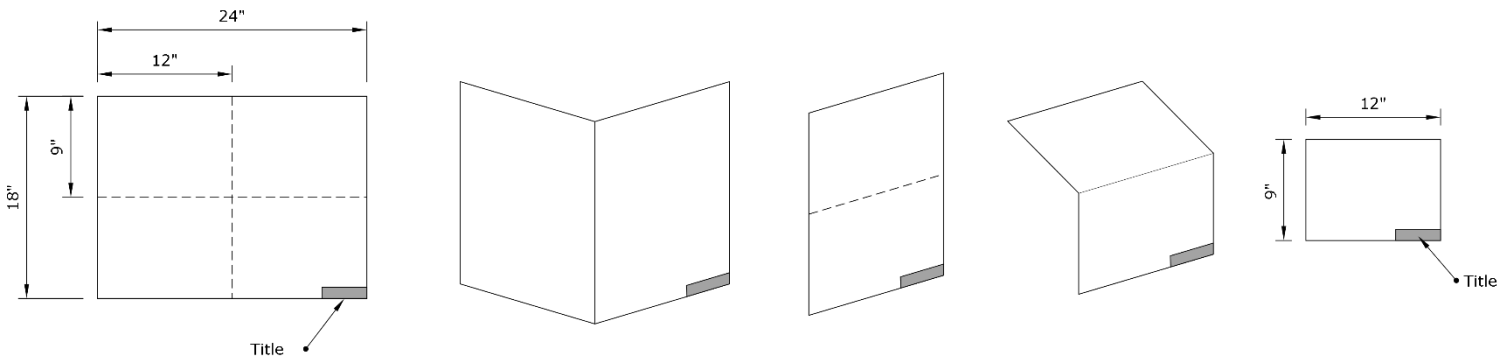

PLEASE NOTE THAT UNFOLDED PLANS WILL NOT BE ACCEPTED BY THE CITY OF ROCKWALL.



DEVELOPMENT CONTACT INFORMATION SHEET

City of Rockwall
Planning and Zoning Department
385 S. Goliad Street
Rockwall, Texas 75087

CITY DEPARTMENT GENERAL CONTACT INFORMATION

| | | |
|-------------------------------------|----------------|--|
| Building Inspection Department | (972) 771-7709 | [Fax] (972) 771-7748 |
| Engineering/Public Works Department | (972) 771-7746 | [Fax] (972) 771-7748 |
| Fire Department | (972) 771-7770 | [Fax] (972) 771-7772 |
| Parks and Recreation Department | (972) 771-7761 | [Fax] (972) 771-7762 |
| Planning & Zoning Department | (972) 771-7745 | planning@rockwall.com |
| Police Department | (972) 771-7714 | N/A |

CITY STAFF CONTACT INFORMATION

| | | | |
|----------------------------|---|----------------|--|
| Ryan Miller, AICP | Director of Planning and Zoning | (972) 771-7745 | rmiller@rockwall.com |
| Henry Lee, AICP | Senior Planner | (972) 772-6434 | hlee@rockwall.com |
| Bethany Ross | Planner | (972) 772-6488 | bross@rockwall.com |
| Angelica Guevara | Planning Technician | (972) 772-6438 | aguevara@rockwall.com |
| Melanie Zavala | Planning Coordinator | (972) 772-6568 | mzavala@rockwall.com |
| Amy Williams, PE | City Engineer/Director of Public Works | (972) 771-7745 | awilliams@rockwall.com |
| Jonathan Browning, PE, CFM | Assistant City Engineer | (972) 771-7746 | jbrowning@rockwall.com |
| Madelyn Price, PE | Engineer | (972) 771-7746 | mprice@rockwall.com |
| Luciana Edwards | Engineering Coordinator | (972) 771-7746 | ledwards@rockwall.com |
| Ariana Kistner | Fire Marshal | (972) 771-7770 | akistner@rockwall.com |
| Rusty McDowell | Building Inspections Supervisor | (972) 771-7709 | rmcdowell@rockwall.com |
| Craig Foshee | Plans Examiner | (972) 771-7709 | cfoshee@rockwall.com |
| Travis Sales | Director of Parks & Recreation/ City Arborist | (972) 771-7761 | tsales@rockwall.com |

SCHOOL DISTRICT CONTACT INFORMATION

| | | | |
|------------|------|----------------|--|
| Will Salee | RISD | (469) 698-7157 | will.salee@rockwallisd.org |
|------------|------|----------------|--|

FRANCHISE UTILITY CONTACT INFORMATION

| | | | |
|-----------------|-----------------------|----------------|--|
| Thomas Nemariam | Atmos Energy | (972) 485-6277 | thomas.nemariam@atmosenergy.com |
| Stephen Geiger | Farmer's Electric | (903) 453-0531 | sgeiger@farmersselectric.coop |
| Frank Spataro | Farmer's Electric | (903) 453-0583 | fspataro@farmersselectric.coop |
| Dawn Flumerfelt | Oncor Electric | (686) 816-1962 | dawn.flumerfelt@oncor.com |
| Scott Baumbach | Oncor Electric | (817) 999-5513 | scott.baumbach@oncor.com |
| Brian Duncan | AT&T | (903) 457-2303 | bduncan5618@att.net |
| Jim Friske | Charter Communication | (817) 298-3632 | jim.friske@chartercom.com |
| Wayne Carter | Charter Communication | (817) 509-6272 | wayne.carter@chartercom.com |
| Lane Selman | TXDOT | (972) 962-3617 | lane.selman@txdot.gov |



DEVELOPMENT PROCESS

City of Rockwall
Planning and Zoning Department
385 S. Goliad Street
Rockwall, Texas 75087

PHASE ONE

PRE-DEVELOPMENT MEETING

The purpose of the Pre-Development Meeting is to allow the applicant to become more familiar with the City's development codes and procedures and to ensure that the application will contain all the required information. Pre-development meetings are not intended to provide every detail associated with the development process; it is a tool to exchange information between City staff and the applicant. We want the applicant to obtain an understanding of the next steps of the process, be made aware of any major issues, and understand which ordinances apply.

 **TIME: One (1) Day**

PHASE TWO

ZONING/SPECIFIC USE PERMIT PROCESS

A requirement for a Specific Use Permit (SUP) or a change in zoning may be necessary to accommodate a proposed use or development. You may consult City staff to obtain zoning information at (972) 771-7745. Once you have determined the zoning classification of your property, consult the *Permissible Use Chart* located in Article IV, *Permissible Uses*, of the Unified Development Code located within the City's Municode (link on the City's website) for a list of permitted uses for each zoning classification. If your proposed use is not allowed in your current zoning classification or if it requires a Specific Use Permit (SUP), contact the Planning department about the possibility of a change in zoning.

 **TIME: 60 Days**

PHASE THREE

MASTER PLAT PROCESS

The purpose of a master plat is to delineate the sequence and timing of a development within a proposed subdivision. Additionally, master plats determine compliance with the City's Comprehensive Plan and the availability and capacity of public improvements need to serve a development. Approval of a master plat authorizes an applicant to submit an application for the approval of a preliminary subdivision plat. Please check with City staff to see if a master plat is required for a development proposal.

 **TIME: 30 Days**

PHASE FOUR

PRELIMINARY PLAT PROCESS

A preliminary plat is intended to provide sufficient information to evaluate and review the general design of a development and to ensure compliance with the City's Comprehensive Plan, Unified Development Code, Thoroughfare Plan, and the Subdivision Ordinance [Chapter 38 of the Code of Ordinances]. Additionally, when a master plat is required the preliminary plat must conform to the approved master plat.

 **TIME: 30 Days**

PHASE FIVE

SITE PLAN PROCESS

Generally, site plan approval is required for all new non-residential and multi-family residential developments (including parking lots) and expansions that enlarge the building footprint and/or parking area by more than 50%. Site plans will be reviewed for conformance with all zoning, subdivision and development regulations of the City.

 **TIME: 30 Days**

PHASE SIX

ENGINEERING PROCESS

Once a project has an approved site plan the project engineer may submit engineering plans to the Engineering Department. After the submittal the staff will prepare comments and relay these comments to the project engineer. Once all staff comments have been adequately addressed and plans have been revised to reflect these changes the plans will be released. For a full scope of the Engineering Department's process and for copies of their application forms please visit the City of Rockwall's website at www.rockwall.com.

 **TIME: 45 Days**

PHASE SEVEN

FINAL PLAT PROCESS

After the preliminary plat has been tentatively approved by the city council, a final plat, in the form of a record, shall be prepared in accordance with the conditions of approval and submitted to the city's engineer and planning director for review and transmission to the Planning & Zoning Commission for recommendation to City Council. Staff will be responsible for filing all approved plats with the County. For questions about filing requirements contact City staff at (972) 771-7745.

 **TIME: 30 Days**

PHASE EIGHT

BUILDING PERMIT PROCESS

Building permits are required before commencing site construction. A Certificate of Occupancy (CO) is issued to the business following the conclusion of your construction activities and must be issued before the facility may be occupied.

 **TIME: 30 Days**

NOTE: Not every project will progress through all of the phases above.



DEVELOPMENT BOARDS & COMMISSIONS

City of Rockwall
Planning and Zoning Department
385 S. Goliad Street
Rockwall, Texas 75087

ARCHITECTURAL REVIEW BOARD (ARB):

The Architectural Review Board is a seven (7) member committee with the purpose of reviewing all site plans within the City. The ARB may require additional information for site plans in an Overlay district, including but not limited to, building materials / color samples, color elevations, artistic renderings, etc. Check with Planning Staff prior to submittal to see if your project will be required to be reviewed by the ARB.

The ARB holds their meetings at 5:00 PM in the City Council Meeting Room (adjacent to the City Council Chambers) on the same evening as the Planning & Zoning Commission Work Session. The ARB Chairman will generally provide the committee's recommendation directly to the Planning & Zoning Commission and applicant at the Planning & Zoning Commission Work Session.

PLANNING & ZONING COMMISSION (P&Z):

The City of Rockwall Planning & Zoning Commission is a seven (7) member commission of appointed officials that holds their meetings at 6:00 PM in the City Council Chambers twice a month. It is imperative that you or your representatives attend both meetings to answer questions the Commission may have. Failure to attend these meetings may delay the application. The first meeting is the Planning & Zoning Work Session. This is an informal meeting that gives the Commission an opportunity to review the request, ask questions of the applicant and recommend any changes at this meeting. As part of the regular development cycle, no action is taken at the Work Session Meeting. The second meeting is the Planning & Zoning Commission's regularly scheduled meeting/public hearing. This is a formal meeting where action is taken on the application. As a part of the decision-making process, the Commission may receive comments during the meeting from the applicant and those interested in issues affecting the City. To ensure that the meeting proceeds in an orderly manner the Commission generally follows the following format:

- (1) The Chairman will call the Commission to order. The minutes of the proceeding meeting shall be submitted for approval.
- (2) The Chairman shall direct attention to the items on the agenda.
- (3) The Commission will receive summary comments from Planning Staff.
- (4) The Chairman will declare the public hearing open if the item is a public hearing.
- (5) The Chairman will announce time for the applicant/representative to come forward to make comments and answer questions regarding the application.
- (6) At this time, the applicant/representative should address the Commission from the podium. Clearly state name and address for the record and proceed with comments. The applicant/representative should be prepared to present sufficient documentation and evidence to justify the proposal.
- (7) If the item is a public hearing the public will be given a chance to address the Commission.
- (8) The applicant will be given a rebuttal.
- (9) The Commission will deliberate and return a verdict.

CITY COUNCIL [1ST & 2ND READINGS]:

The City of Rockwall City Council has two meetings a month that are held at 6:00 PM on the 1st and 3rd Mondays of each month. The City Council is a legislative body that governs the City of Rockwall and is composed of seven (7) members including the Mayor, Mayor Pro-Tem, and five (5) council members. All members of the City Council are elected 'at large' since the City of Rockwall is not divided into specific precincts or districts for municipal elections. Certain cases may require the approval of the City Council (e.g. Zoning, Platting, and Special Exceptions). In most platting cases, one (1) City Council meeting will be required for approval; however, in cases where a project has an ordinance associated with it a second City Council meeting will be required to have a second reading of the ordinance to satisfy state and local requirements (this is most common with Zoning Cases).

For Questions Concerning this Information Please Contact the Planning & Zoning Department at (972) 771-7745.



STANDARD PLAT WORDING FOR FINAL PLATS AND REPLATS

City of Rockwall
Planning and Zoning Department
385 S. Goliad Street
Rockwall, Texas 75087

GENERAL REFERENCE: CHAPTER 38.7, *SUBDIVISION AND PLATTING PROCEDURES*, OF THE MUNICIPAL CODE OF ORDINANCES

OWNER'S CERTIFICATION [PUBLIC DEDICATION]

STATE OF TEXAS
COUNTY OF ROCKWALL

WHEREAS [OWNER'S NAME], BEING THE OWNER OF A TRACT OF land in the County of Rockwall, State of Texas, said tract being described as follows: **[LEGAL DESCRIPTION]**

NOW, THEREFORE, KNOW ALL MEN BY THESE PRESENTS:

STATE OF TEXAS
COUNTY OF ROCKWALL

I (we) the undersigned owner(s) of the land shown on this plat, and designated herein as the **[SUBDIVISION NAME]** subdivision to the City of Rockwall, Texas, and whose name is subscribed hereto, hereby dedicate to the use of the public forever all streets, alleys, parks, water courses, drains, easements and public places thereon shown on the purpose and consideration therein expressed. I (we) further certify that all other parties who have a mortgage or lien interest in the **[SUBDIVISION NAME]** subdivision have been notified and signed this plat. I (we) understand and do hereby reserve the easement strips shown on this plat for the purposes stated and for the mutual use and accommodation of all utilities desiring to use or using same. I (we) also understand the following;

1. No buildings shall be constructed or placed upon, over, or across the utility easements as described herein.
2. Any public utility shall have the right to remove and keep removed all or part of any buildings, fences, trees, shrubs, or other growths or improvements which in any way endanger or interfere with construction, maintenance or efficiency of their respective system on any of these easement strips; and any public utility shall at all times have the right of ingress or egress to, from and upon the said easement strips for purpose of construction, reconstruction, inspecting, patrolling, maintaining, and either adding to or removing all or part of their respective system without the necessity of, at any time, procuring the permission of anyone.
3. The City of Rockwall will not be responsible for any claims of any nature resulting from or occasioned by the establishment of grade of streets in the subdivision.
4. The developer/property owner and subdivision engineer shall bear total responsibility for storm drain improvements.
5. The developer/property owner shall be responsible for the necessary facilities to provide drainage patterns and drainage controls such that properties within the drainage area are not adversely affected by storm drainage from the development.
6. No house dwelling unit, or other structure shall be constructed on any lot in this addition by the owner or any other person until the developer and/or owner has complied with all requirements of the Subdivision Regulations of the City of Rockwall regarding improvements with respect to the entire block on the street or streets on which property abuts, including the actual installation of streets with the required base and paving, curb and gutter, water and sewer, drainage structures, storm structures, storm sewers, and alleys, all according to the specifications of the City of Rockwall; or

Until an escrow deposit, sufficient to pay for the cost of such improvements, as determined by the city's engineer and/or city administrator, computed on a private commercial rate basis, has been made with the city secretary, accompanied by an agreement signed by the developer and/or owner, authorizing the city to make such improvements at prevailing private commercial rates, or have the same made by a contractor and pay for the same out of the escrow deposit, should the developer and/or owner fail or refuse to install the required improvements within the time stated in such written agreement, but in no case shall the City be obligated to make such improvements itself. Such deposit may be used by the owner and/or developer as progress payments as the work progresses in making such improvements by making certified requisitions to the city secretary, supported by evidence of work done; or

Until the developer and/or owner files a corporate surety bond with the city secretary in a sum equal to the cost of such improvements for the designated area, guaranteeing the installation thereof within the time stated in the bond, which time shall be fixed by the city council of the City of Rockwall.

I (we) further acknowledge that the dedications and/or exaction's made herein are proportional to the impact of the Subdivision upon the public services required in order that the development will comport with the present and future growth needs of the City; I (we), my (our) successors and assigns hereby waive any claim, damage, or cause of action that I (we) may have as a result of the dedication of exactions made herein.

PROPERTY OWNER SIGNATURE

SIGNATURE OF PARTY WITH MORTGAGE OR LIEN INTEREST **[IF APPLICABLE]**

STATE OF TEXAS
COUNTY OF ROCKWALL

Before me, the undersigned authority, on this day personally appeared **[PROPERTY OWNER]**, known to me to be the person whose name is subscribed to the foregoing instrument, and acknowledged to me that he executed the same for the purpose and consideration therein stated.

Given upon my hand and seal of office this **[DAY]** day of **[MONTH]**, **[YEAR]**.

NOTARY PUBLIC IN AND FOR THE STATE OF TEXAS

MY COMMISSION EXPIRES

GENERAL NOTES [Please add this to any other notes included on the plat.]

- (1) Subdivider's Statement. Selling a portion of this addition by metes and bounds is unlawful and a violation of the *Subdivision Ordinance* of the City of Rockwall and *Chapter 212, Municipal Regulation of Subdivisions and Property Development, of the Texas Local Government Code*, and shall be subject to the City of Rockwall withholding utilities and building permits.
- (2) Public Improvement Statement. It shall be the policy of the City of Rockwall to withhold issuing buildings permits until all streets, water, sewer and storm drainage systems have been accepted by the City. The approval of a subdivision plat by the City of Rockwall does not constitute any representation, assurance or guarantee that any building within such subdivision plat shall be approved, authorized, or permit issued, nor shall such approval constitute any representation, assurance or guarantee by the City of Rockwall of the adequacy and availability for water and sanitary sewer for personal use and fire protection within such subdivision plat, as required under the *Subdivision Ordinance* of the City of Rockwall.
- (3) Drainage and Detention Easements. The property owner shall be responsible for maintaining, repairing, and replacing and shall bear sole liability of all systems within the drainage and detention easements.
- (4) Fire Lanes. All *Fire Lanes* will be constructed, maintained, repaired and replaced by the property owner. *Fire Lanes* shall be constructed in accordance with the approved Civil Engineering Plans for both on-site and off-site *Fire Lane* improvements.
- (5) Street Appurtenances. All decorative signage, posts, or lights installed in public right-of-way shall be installed, maintained, repaired, and replaced by the Homeowner's Association (HOA).

SURVEYOR'S/REGISTERED ENGINEER CERTIFICATE

NOW, THEREFORE KNOW ALL MEN BY THESE PRESENTS:

THAT I, **[SURVEYOR'S NAME]**, do hereby certify that I prepared this plat from an actual and accurate survey of the land, and that the corner monuments shown thereon were properly placed under my personal supervision.

SURVEYOR SIGNATURE **[OR]** REGISTERED ENGINEER

REGISTERED PUBLIC SURVEYOR NO. **[OR]**
PROFESSIONAL ENGINEER NO.

STANDARD CITY SIGNATURE BLOCK

APPROVED: I hereby certify that the above and forgoing *Subdivision Plat* was reviewed by the Planning and Zoning Commission and approved by the City Council of the City of Rockwall, Texas for the preparation of a *Final Plat* on the **[DAY]** day of **[MONTH]**, **[YEAR]**.

MAYOR OF THE CITY OF ROCKWALL

PLANNING AND ZONING CHAIRMAN

CITY SECRETARY

CITY ENGINEER

ROCKWALL COUNTY JUDGE SIGNATURE BLOCK [ADD THIS BLOCK IF THE PROPERTY IS LOCATED OUTSIDE THE CITY LIMITS]

ROCKWALL COUNTY JUDGE

DATE

ADMINISTRATIVE APPROVAL BLOCK FOR PLATS (E.G. MINOR & AMENDING) [USE IN LIEU OF THE STANDARD BLOCK]

APPROVED: I hereby certify that the above and foregoing *subdivision plat* – being an addition to the City of Rockwall, Texas – was approved by the Director of Planning and Zoning and the City Engineer of the City of Rockwall on the **[DAY]** day of **[MONTH]**, **[YEAR]**.

DIRECTOR OF PLANNING & ZONING

CITY ENGINEER

PLAT FILING REQUIREMENTS [AFTER APPROVAL OF THE PLAT]

Final plats and replats must be filed with the County Clerk within 180 days of the City Council approval date or the plat will be considered void. If the plat is voided, it must be re-approved by the Planning & Zoning Commission and City Council.

All plats will be filed with Rockwall County by City of Rockwall staff; however, the applicant is responsible for providing City staff with the appropriate plat information necessary to file the plat with the County Clerk. This includes a minimum of one (1) signed mylar sets (18" x 24") with current Tax Certificates and a check for the filing fees made payable to the **Rockwall County Clerk**. Tax Certificates can be obtained from the Rockwall County Appraisal District located at 841 Justin Road, Rockwall, Texas 75087.

FILING FEES:

Mylars: \$49.00 per page for the 1st set only (*No charge for additional sets*).

Tax Certificates: \$29.00 for the 1st certificate and \$4.00 for each additional certificate.

Per Rockwall County:

*Please note if submitting mylars between September 1st through December 31st, **tax receipts** must also be filed with the plat. The filing of the tax receipt will incur a filing fee of \$4.00 per tax receipt, made payable to the **Rockwall County Clerk**.



STANDARD SITE PLAN WORDING

City of Rockwall
Planning and Zoning Department
385 S. Goliad Street
Rockwall, Texas 75087

GENERAL REFERENCE: SECTION 212.009 OF CHAPTER 212, MUNICIPAL REGULATION OF SUBDIVISIONS AND PROPERTY DEVELOPMENT, OF THE TEXAS LOCAL GOVERNMENT CODE

SITE PLAN SIGNATURE BLOCK

APPROVED:

I hereby certify that the above and foregoing site plan for a development in the City of Rockwall, Texas, was approved by the Planning & Zoning Commission of the City of Rockwall on the *[DAY]* day of *[MONTH]*, *[YEAR]*.

WITNESS OUR HANDS, this *[DAY]* day of *[MONTH]*, *[YEAR]*.

Planning & Zoning Commission, Chairman

Director of Planning and Zoning



MATERIAL SAMPLE BOARD STANDARDS

City of Rockwall
Planning and Zoning Department
385 S. Goliad Street
Rockwall, Texas 75087

SAMPLE BOARD GUIDELINES

These guidelines are to be used in the preparation of Material Sample Boards for review by the Architectural Review Board (ARB). Additionally, Material Sample Boards may be used by the Planning & Zoning Commission and/or City Council at public hearings. The guidelines also identify additional information that may be needed to demonstrate aspects of a new development project, including proposed modifications to existing developments.

An example of a Material Sample Board (*Figure 1.1*) is on the back of this form. The Material Sample Board must be submitted as part of the Site Plan packet prior to deeming the formal application complete. For assistance in the preparation of this exhibit, please call (972) 771-7745 or email us at planning@rockwall.com.

MATERIAL SAMPLE BOARD STANDARDS

All Material Sample Boards shall be 11" x 17". One (1) or more Material Sample Boards may be necessary to reflect all proposed colors and materials for the project. Material Sample Boards must include the following:

1. **TITLE BLOCK.** The Title Block must be located in the lower right-hand corner and include the name, phone number and address of the applicant and owner, address or location of the project, project case number blank (your Case Manager will write in the case number at the time of submittal), and the date of latest revision.
2. **LEGEND.** The legend must include a description of all symbols used to identify colors and materials.
3. **MATERIAL SAMPLES.**
 - a. Provide ACTUAL SAMPLES of all materials proposed for the building. Loose materials will not be accepted. Exterior material samples must show finishes with colors for walls, fascia, trim, etc.; style and color of roofing material; glass used for windows and doors; color of window mullions; and related exterior materials.
 - b. A brochure or photograph may be used if an actual material sample is not available and if it is an accurate representation of the material to be used.
4. **COLOR PAINT SAMPLES.** Provide color samples for all exterior surfaces and materials. Colors must be provided for walls, roofing, window trim, doors, masonry, and other exterior colors. A brochure or photograph may be used if it is an accurate representation of the color to be used.

CONSISTENCY BETWEEN MATERIALS SAMPLE BOARD AND COLORED ELEVATION PLAN

The sample of the color must be an accurate representation of the proposed color to be used on a particular improvement. The colors depicted on the Materials Sample Board must be the same as the colors used on the colored building elevations.

Figure 1.1: Sample Board (NOTE: A Printed Piece of Paper will not be an acceptable alternative to a material sample board).

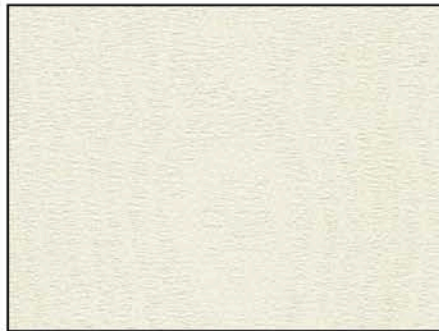

1. Tilt-Wall, Alabaster, Turner



4. Steel, Rough Striated Finish, HLZ



2. Tilt-Wall, Woodland Olive, Turner



5. Aluminum, Brushed Aluminum, HLZ



3. Tilt-Wall, Dark Grey, Turner



6. Natural Stone, NS-540, Interstate Co.



7. Mirrored Glass, Dark Grey, Glassco

| |
|------------------------------|
| Applicant Information |
| Name |
| Company |
| Address |
| Phone |
| Email |

| |
|--------------------------|
| Owner Information |
| Name |
| Company |
| Address |
| Phone |
| Email |

| |
|---------------------|
| Project Name |
| Case Number |

11"

17"



CHECKLIST FOR PLAT SUBMITTALS

City of Rockwall
 Planning and Zoning Department
 385 S. Goliad Street
 Rockwall, Texas 75087

Case Type:

- Minor/Amending Plat Replat
 Final Plat Preliminary Plat
 Master Plat Vacation Plat

Case Number

Reviewed By:

Review Date:

NOTES: The requirements listed below are based on the case type, which is indicated in the '[]' below the requirement description. On the checklist below a Replat, Minor Subdivision Plat, and Vacation Plat would be required to meet all the same requirements as a Final Plat.

| Requirements | ✓= OK | N/A | Comments |
|--|--------------------------|--------------------------|--|
| Case Number [Final Plat, Preliminary Plat & Master Plat] | <input type="checkbox"/> | <input type="checkbox"/> | The case number will be provided by staff and placed in the lower right-hand corner of all new submittals. |
| Items Necessary for Plat Review: | | | |
| ✓ Plat | <input type="checkbox"/> | <input type="checkbox"/> | [Final Plat, Preliminary Plat & Master Plat] |
| ✓ Treescape Plan | <input type="checkbox"/> | <input type="checkbox"/> | If Applicable [Final Plat & Preliminary Plat] |
| ✓ Landscape Plan | <input type="checkbox"/> | <input type="checkbox"/> | If Applicable [Final Plat & Preliminary Plat] |
| ✓ Plat Reinstatement Request | <input type="checkbox"/> | <input type="checkbox"/> | Check w/ Planning Staff |
| Submittal Requirements [Final Plat, Preliminary Plat & Master Plat] | <input type="checkbox"/> | <input type="checkbox"/> | Four (4) large (18" x 24") folded copies and one (1) PDF digital copy of each plat is required at the time of submittal. |
| Engineering Information [Final Plat] | <input type="checkbox"/> | <input type="checkbox"/> | Provide accurate plat dimensions with all engineering information necessary to reproduce the plat on the ground. ENGINEERING SUBMITTAL AND APPROVAL REQUIRED PRIOR TO SUBMITTING AN APPLICATION FOR FINAL PLAT. |
| Title Block: | | | |
| Type of Plat [Master, Preliminary, Final or Replat] | | | |
| Subdivision Name (Proposed or Approved) | | | |
| Lot / Block Designation | <input type="checkbox"/> | <input type="checkbox"/> | Provide the title block information in the lower right-hand corner. |
| Number of Lots (Proposed) | | | |
| Total Acreage | | | |
| City, State, County | | | |
| Owner, Developer, and/or Surveyor/Engineer (Name/Address/Phone Number/Date of Preparation) [Final Plat & Preliminary Plat] | <input type="checkbox"/> | <input type="checkbox"/> | This includes the names and addresses of the sub dividers, record owner, land planner, engineer and/or surveyor. The date of plat preparation should also be put in the lower right-hand corner. |
| Survey Monuments/State Plane Coordinates [Final Plat] | <input type="checkbox"/> | <input type="checkbox"/> | The location of the development is required to be tied to a Rockwall monument, or tie two (2) corners to state plan coordinates (NAD 83 State Plane Texas, North Central [7202], US Survey Feet). |
| Vicinity Map [Final Plat & Preliminary Plat] | <input type="checkbox"/> | <input type="checkbox"/> | A Vicinity Map should show the boundaries of the proposed subdivision relative to the rest of the city. |
| North Point [Final Plat & Preliminary Plat] | <input type="checkbox"/> | <input type="checkbox"/> | The north point or north arrow must be facing true north (or straight up) on all plans, unless the scale of the drawings or scope of the project requires a different position. |
| Numeric and Graphic Scale [Final Plat & Preliminary Plat] | <input type="checkbox"/> | <input type="checkbox"/> | Plats should be drawn to an Engineering Scale of 1"=50', 1"=100', etc... |
| Subdivision (Boundary, Acreage, and Square Footage) [Final Plat, Preliminary Plat & Master Plat] | <input type="checkbox"/> | <input type="checkbox"/> | Indicate the subdivision boundary lines, and acreage and square footage. For Master Plats provide a schematic layout of the entire tract to be subdivided, any remainder tracts and its relationship to adjacent property and existing adjoining developments. |
| Lot and Block (Designation, Width, Depth and Area) [Final Plat & Preliminary Plat] | <input type="checkbox"/> | <input type="checkbox"/> | Identification of each lot and block by number or letter. For each lot indicate the square footage and acreage or provide a calculation sheet. Also provide a lot count. |
| Dwelling Units/Population Density [Master Plat] | <input type="checkbox"/> | <input type="checkbox"/> | Indicate the proposed number of dwelling units and population densities. |
| Building Setbacks [Final Plat & Preliminary Plat] | <input type="checkbox"/> | <input type="checkbox"/> | Label the building lines where adjacent to a street. |
| Easements [Final Plat & Preliminary Plat] | <input type="checkbox"/> | <input type="checkbox"/> | Label all existing and proposed easements relative to the site and include the type, purpose and width. |
| City Limits [Final Plat, Preliminary Plat & Master Plat] | <input type="checkbox"/> | <input type="checkbox"/> | Indicate the location of the City Limits, contiguous or within the platting area. |
| Utilities (P) | <input type="checkbox"/> | <input type="checkbox"/> | Indicate the locations of all existing and proposed utilities. Include the size and type of each. |

| | | | |
|--|--------------------------|--------------------------|---|
| Property Lines <i>[Final Plat, Preliminary Plat & Master Plat]</i> | <input type="checkbox"/> | <input type="checkbox"/> | Provide all the proposed and platted property lines. |
| Streets <i>[Final Plat, Preliminary Plat & Master Plat]</i> | <input type="checkbox"/> | <input type="checkbox"/> | Label all proposed and existing streets with the proposed or approved names. For Master Plats indicate the existing arterials and collector streets to serve the land to be platted consistent with the Thoroughfare Plan or proposed amendments. |
| Right-Of-Way and Centerline <i>[Final Plat, Preliminary Plat & Master Plat]</i> | <input type="checkbox"/> | <input type="checkbox"/> | Label the right-of-way width and street centerline for each street both within and adjacent to the development. |
| Additional Right-Of-Way <i>[Final Plat & Preliminary Plat]</i> | <input type="checkbox"/> | <input type="checkbox"/> | Indicate the location and dimensions of any proposed right-of-way dedication. |
| Corner Clips <i>[Final Plat & Preliminary Plat]</i> | <input type="checkbox"/> | <input type="checkbox"/> | Indicate all existing and proposed corner clips and any subsequent dedication. |
| Median Openings <i>[Preliminary Plat]</i> | <input type="checkbox"/> | <input type="checkbox"/> | Locate and identify existing and/or proposed median openings and left turn channelization. |
| Topographical Contours <i>[Preliminary Plat & Master Plat]</i> | <input type="checkbox"/> | <input type="checkbox"/> | Topographical information and physical features to include contours at 2-foot intervals. |
| Flood Elevations <i>[Preliminary Plat & Master Plat]</i> | <input type="checkbox"/> | <input type="checkbox"/> | Show 100-Year & 50-Year floodplain and floodway boundaries (if applicable). |
| Drainage Areas <i>[Preliminary Plat & Master Plat]</i> | <input type="checkbox"/> | <input type="checkbox"/> | Show all drainage areas and all proposed storm drainages areas with sizes if applicable. |
| Wooded Areas <i>[Preliminary Plat & Master Plat]</i> | <input type="checkbox"/> | <input type="checkbox"/> | Indicate the boundaries of all adjacent wooded areas. |
| Zoning and Land Use Information <i>[Preliminary Plat & Master Plat]</i> | <input type="checkbox"/> | <input type="checkbox"/> | Indicate all proposed land uses, and existing and proposed zoning classifications. For Master Plats indicate the proposed major categories of land use. |
| Existing Man-Made Features <i>[Master Plat]</i> | <input type="checkbox"/> | <input type="checkbox"/> | Indicate all significant man-made features such as railroad, roads, buildings, utilities or other physical structures as shown on USGS topographic maps, utility company records and city records when such features affect the plans. |
| Parks and Open Space <i>[Preliminary Plat & Master Plat]</i> | <input type="checkbox"/> | <input type="checkbox"/> | Identify the dimensions, names and description of all parks and open spaces, both existing and proposed. For Master Plats also indicate schools and other public uses as consistent with those shown in the comprehensive plan. |
| Proposed Improvements <i>[Preliminary Plat]</i> | <input type="checkbox"/> | <input type="checkbox"/> | Indicate how the proposed improvements would relate to those in the surrounding area. |
| Water Sources <i>[Preliminary Plat]</i> | <input type="checkbox"/> | <input type="checkbox"/> | Indicate water sources inside the city limits or in the extraterritorial jurisdiction (ETJ). |
| Sewage Disposal <i>[Preliminary Plat]</i> | <input type="checkbox"/> | <input type="checkbox"/> | Indicate sewage disposal method inside the city limits or in the extraterritorial jurisdiction (ETJ). |
| Adjacent Properties <i>[Final Plat & Preliminary Plat]</i> | <input type="checkbox"/> | <input type="checkbox"/> | Record owners of contiguous parcels of subdivided land, names and lot patterns of contiguous subdivisions, approved Concept Plans, reference recorded subdivision plats adjoining platted land by record name and by deed record volume and page. |
| Phasing Plan <i>[Master Plat]</i> | <input type="checkbox"/> | <input type="checkbox"/> | Designation of each phase of development within the subdivision, the order of development, and a schedule for the development of each phase of the master plan. |
| Dedication <i>[Final Plat, Preliminary Plat & Master Plat]</i> | <input type="checkbox"/> | <input type="checkbox"/> | Indicate the boundary lines, dimensions and descriptions, of spaces to be dedicated for public use of the inhabitants of the development. |
| Statement of Service <i>[Master Plat]</i> | <input type="checkbox"/> | <input type="checkbox"/> | Provide a detailed statement of how the proposed subdivision will be served by water, wastewater, roadway and drainage facilities that have adequate capacity to serve the development. |
| Standard Plat Wording <i>[Final Plat]</i> | <input type="checkbox"/> | <input type="checkbox"/> | Provide the appropriate plat wording provided in the application packet that details the designation of the entity responsible for the operation and maintenance of any commonly held property and a waiver releasing the city of such responsibility, a waiver releasing the City for damages in establishment or alteration of grade. |
| Legal Description <i>[Final Plat]</i> | <input type="checkbox"/> | <input type="checkbox"/> | Place the Legal Description (Metes and Bounds Description/Field Notes) where indicated in the Owner's Certificate per the application packet. |
| Storm Drainage Improvements Statement <i>[Final Plat]</i> | <input type="checkbox"/> | <input type="checkbox"/> | Provide the appropriate statement of developer responsibility for storm drainage improvements found in the application packet. |
| Dedication Language <i>[Final Plat]</i> | <input type="checkbox"/> | <input type="checkbox"/> | Provide the instrument of dedication or adoption signed by the owners, which is provided in the application packet. |
| Seal/Signature <i>[Final Plat]</i> | <input type="checkbox"/> | <input type="checkbox"/> | Required to have the seal and signature of surveyor responsible for the surveying the development and/or the preparation of the plat. |
| Public Improvement Statement <i>[Final Plat]</i> | <input type="checkbox"/> | <input type="checkbox"/> | Proved the appropriate statement indicating that no building permits will be issued until all public improvements are accepted by the City as provided in the application packet. |
| Plat Approval Signatures <i>[Final Plat]</i> | <input type="checkbox"/> | <input type="checkbox"/> | Provide a space for signatures attesting approval of the plat. |

| | | | |
|--|--------------------------|--------------------------|--|
| Compliance with Preliminary Plat <i>[Final Plat]</i> | <input type="checkbox"/> | <input type="checkbox"/> | Does the plat comply with all the special requirements developed in the preliminary plat review? |
| Review Plans with Franchise Utility Companies <i>[Final Plat, Preliminary Plat & Master Plat]</i> | <input type="checkbox"/> | <input type="checkbox"/> | Review the proposed plans and plat with electric, gas, cable and phone companies. |



CHECKLIST FOR SITE PLAN SUBMITTALS

City of Rockwall
 Planning and Zoning Department
 385 S. Goliad Street
 Rockwall, Texas 75087

CASE NUMBER:

OVERLAY DISTRICT:

REVIEWED BY:

REVIEW DATE:

1.1 GENERAL INFORMATION FOR ALL PLANS SUBMITTED

| Requirements | ✓= OK | N/A | Comments | UDC Reference |
|---|--------------------------|--------------------------|--|------------------------|
| Items Necessary for Site Plan Review: | | | | <i>Per Application</i> |
| ✓ Site Plan | <input type="checkbox"/> | <input type="checkbox"/> | | §03.04.A, of Art. 11 |
| ✓ Landscape Plan | <input type="checkbox"/> | <input type="checkbox"/> | | - |
| ✓ Treescape Plan | <input type="checkbox"/> | <input type="checkbox"/> | | - |
| ✓ Photometric Plan | <input type="checkbox"/> | <input type="checkbox"/> | | - |
| ✓ Building Elevations | <input type="checkbox"/> | <input type="checkbox"/> | | - |
| Building Material Sample Board and Color Rendering of Building Elevations | <input type="checkbox"/> | <input type="checkbox"/> | If required the sample board should detail all building materials, with each material clearly labeled and indicating manufacturer info, color, etc. Check with Planning Staff to see which is appropriate for the submitted project. | §03.04.A, of Art. 11 |
| Submittal Requirements | <input type="checkbox"/> | <input type="checkbox"/> | Four (4) large (24" x 36") folded copies and one (1) PDF digital copy of each plan is required at the time of submittal. | §03.04.A, of Art. 11 |
| Is the property properly platted? | <input type="checkbox"/> | <input type="checkbox"/> | Indicate if the property has been properly platted. | - |
| Title Block (Project Name, Legal Description and/or Address) | <input type="checkbox"/> | <input type="checkbox"/> | The title block is to be located in the lower right-hand corner of all sheets and contain the project name, street address, and/or the lot and block designation. | §03.04.A, of Art. 11 |
| Case Number | <input type="checkbox"/> | <input type="checkbox"/> | The case number should be placed in the lower right-hand corner below the title block of all sheets. | §03.04.A, of Art. 11 |
| Owners (Name, Address, and Phone Number) | <input type="checkbox"/> | <input type="checkbox"/> | The owners name, address, and phone number are required to be in the lower right-hand corner left of the title block. | §03.04.A, of Art. 11 |
| Developer (Name, Address, and Phone Number) | <input type="checkbox"/> | <input type="checkbox"/> | The name, address, and phone number of the person or company that prepared the plans are required in the lower right-hand corner left of the title block. | §03.04.A, of Art. 11 |
| North Point | <input type="checkbox"/> | <input type="checkbox"/> | The north point or north arrow must be facing true north (or straight up) on all plans, unless the scale of the drawings or scope of the project requires a different position. | §03.04.A, of Art. 11 |
| Numeric and Graphic Scale | <input type="checkbox"/> | <input type="checkbox"/> | The recommended engineering scales are 1" = 20', 1" = 40', etc. ... with a maximum of 1" = 100'. | §03.04.A, of Art. 11 |
| Vicinity Map | <input type="checkbox"/> | <input type="checkbox"/> | The vicinity map should locate the site relative to the nearest major roadways in a one-half mile radius. | §03.04.A, of Art. 11 |
| Signature Block | <input type="checkbox"/> | <input type="checkbox"/> | Standard signature block with signature space for the Planning & Zoning Chairman and Planning Director. | §03.04.A, of Art. 11 |
| Date | <input type="checkbox"/> | <input type="checkbox"/> | The date that the plans were prepared is required on all submittals. | §03.04.A, of Art. 11 |
| Proposed Land Use: | | | Indicate the proposed use for this site. Additionally, indicate the proposed use for all structures. | §03.04.A, of Art. 11 |
| ✓ Commercial | <input type="checkbox"/> | <input type="checkbox"/> | Land Uses Permitted in the RO, NS, GR, C, DT, RC & Designated Planned Development District Ordinances. | - |
| ✓ Industrial | <input type="checkbox"/> | <input type="checkbox"/> | Land Uses Permitted in the RT, LI, HI & Designated Planned Development District Ordinances. | - |

2.1 SITE PLAN: MISCELLANEOUS AND DENSITY & DIMENSIONAL INFORMATION

| Requirements | ✓= OK | N/A | Comments | UDC Reference |
|--|--------------------------|--------------------------|--|----------------------|
| Total Lot or Site Area (Acreage and Square Footage) | <input type="checkbox"/> | <input type="checkbox"/> | If the site is part of a larger tract include a key map showing the entire tract of land and the location of the site being planned. | §03.04.B, of Art. 11 |

| | | | | |
|---|--------------------------|--------------------------|--|----------------------|
| Perimeter Dimensions of the Site | <input type="checkbox"/> | <input type="checkbox"/> | Indicate the perimeter dimensions of the site in feet. | §03.04.B, of Art. 11 |
| Buildings (Square Footage) | <input type="checkbox"/> | <input type="checkbox"/> | Indicate the location and total square footage of all existing and planned buildings on the site. | §03.04.B, of Art. 11 |
| Perimeter Dimensions of all Buildings | <input type="checkbox"/> | <input type="checkbox"/> | Indicate the wall lengths of all buildings on the site. | §03.04.B, of Art. 11 |
| Distance Between Buildings | <input type="checkbox"/> | <input type="checkbox"/> | Indicate the distance between all existing and planned buildings located on the site. | §03.04.B, of Art. 11 |
| Distance Between Buildings and Property Lines | <input type="checkbox"/> | <input type="checkbox"/> | Indicate the distance between all property lines and existing and planned buildings located on the site. | §03.04.B, of Art. 11 |
| Indicate all Property Lines | <input type="checkbox"/> | <input type="checkbox"/> | Indicate all existing property lines. If the site plan requires a platting case that will alter the property lines show the proposed changes in a different line weight. | §03.04.B, of Art. 11 |
| Indicate all Building Setbacks | <input type="checkbox"/> | <input type="checkbox"/> | Indicate all building setbacks adjacent to right-of-way. | §03.04.B, of Art. 11 |
| Indicate all Easements | <input type="checkbox"/> | <input type="checkbox"/> | Additionally, indicate all utilities both existing and proposed. | §03.04.B, of Art. 11 |
| Indicate all Drive/Turning Radii | <input type="checkbox"/> | <input type="checkbox"/> | | §03.04.B, of Art. 11 |
| Indicate all Drive Widths | <input type="checkbox"/> | <input type="checkbox"/> | | §03.04.B, of Art. 11 |
| Indicate all Fire Lanes | <input type="checkbox"/> | <input type="checkbox"/> | Indicate and label the widths of all fire lanes existing and proposed for the site. | §03.04.B, of Art. 11 |
| Indicate location of all Fire Hydrants | <input type="checkbox"/> | <input type="checkbox"/> | | §03.04.B, of Art. 11 |
| Indicate all Sidewalks | <input type="checkbox"/> | <input type="checkbox"/> | Indicate and label the widths of all sidewalks existing and proposed for the site. | §03.04.B, of Art. 11 |
| Adjacent Street Right-Of-Way | <input type="checkbox"/> | <input type="checkbox"/> | Reference the City's Master Transportation Plan for right-of-way information. | §03.04.B, of Art. 11 |
| Label all Adjacent Street Name | <input type="checkbox"/> | <input type="checkbox"/> | Label all adjacent existing and proposed street names. | §03.04.B, of Art. 11 |
| Adjacent Street Centerlines | <input type="checkbox"/> | <input type="checkbox"/> | Indicate the street centerline for all existing and proposed streets. | §03.04.B, of Art. 11 |
| Median Breaks in Adjacent Streets | <input type="checkbox"/> | <input type="checkbox"/> | | §03.04.B, of Art. 11 |

2.2 SITE PLAN: PARKING INFORMATION

| Requirements | ✓= OK | N/A | Comments | UDC Reference |
|--------------------------------------|--------------------------|--------------------------|--|----------------------|
| Dimension of a Typical Parking Space | <input type="checkbox"/> | <input type="checkbox"/> | See the comment section in <i>Adequate Parking and Maneuvering</i> below. | §05.03, of Art. 06 |
| Parking Table | <input type="checkbox"/> | <input type="checkbox"/> | Provide parking table indicating the total number of required parking spaces by use, the total number of required handicapped parking spaces and the total parking provided. | §05.01, of Art. 06 |
| Handicap Parking Spaces Shown | <input type="checkbox"/> | <input type="checkbox"/> | | §05.04, of Art. 06 |
| Adequate Parking | <input type="checkbox"/> | <input type="checkbox"/> | <i>Reference Table 3 of Article VI.</i> | Table 5, Art. 06 |
| Adequate Parking and Maneuvering | <input type="checkbox"/> | <input type="checkbox"/> | All parking spaces and aisle dimensions shall conform to the off-street parking requirements in section 2.19 of the City's Standards of Design and Construction (<i>Check w/ the Engineering Department</i>). | §05.03.C, of Art. 06 |
| Adequate Loading Area | <input type="checkbox"/> | <input type="checkbox"/> | Loading spaces shall be a minimum of 12 feet in width, 65 feet in length, and 14 feet in height except as may otherwise be approved by the city engineer (<i>Art. VI 6.5 Loading Requirements</i>). | §06.04, of Art. 06 |
| Adequate Loading Maneuvering | <input type="checkbox"/> | <input type="checkbox"/> | It is also the purpose of this Article to require allocation of sufficient off-street/on-site loading facilities by businesses and industry to ensure that the loading and unloading of vehicles will not interfere with traffic flow or block roadways or fire lanes. | §01.02, of Art. 06 |
| Type and Depth of Paving Material | <input type="checkbox"/> | <input type="checkbox"/> | Indicate the type and depth of the paving material and provide a detail or cut-sheet. All required parking and loading areas shall be constructed of concrete, but may have a surface treatment of brick, stone or other similar material. | §03.02, of Art. 06 |

2.3 SITE PLAN: SIGNAGE

| Requirements | ✓= OK | N/A | Comments | UDC Reference |
|---|-------|-----|----------|---------------|
| NOTE: All signage shall conform to Chapter 32 of the Rockwall Municipal Code of Ordinance, unless otherwise specified in an Overlay District or Planned Development District with specific signage requirements. | | | | |

| | | | | |
|------------------------------|--------------------------|--------------------------|---|----------------------|
| Proposed or Existing Signage | <input type="checkbox"/> | <input type="checkbox"/> | Indicate the location and type of all proposed and/or existing signage on the site plan. Additionally, provide a detail or cut-sheet showing the elevations, lighting and dimensions of the proposed signage. | §06.02.F, of Art. 05 |
|------------------------------|--------------------------|--------------------------|---|----------------------|

2.4 SITE PLAN: SCREENING

| Requirements | √= OK | N/A | Comments | UDC Reference |
|---|--------------------------|--------------------------|---|----------------------|
| Indicate the Type and Location of any Existing and/or Proposed Fences | <input type="checkbox"/> | <input type="checkbox"/> | Label the height and type of fence proposed or existing. | §08.02.F, of Art. 08 |
| Utility Equipment Screening (Pad or Ground Mounted) | <input type="checkbox"/> | <input type="checkbox"/> | Pad mounted utility equipment, and air conditioning units, shall be screened from horizontal view from any adjacent public street and from any adjacent property. Utility equipment and air conditioning units shall be screened utilizing plantings, berms, or walls matching the main structure. | §01.05.C, of Art. 05 |
| Utility Equipment Screening (Roof Mounted) | <input type="checkbox"/> | <input type="checkbox"/> | All buildings must be designed such that no roof mounted mechanical equipment, HVAC, or satellite dishes shall be visible from any direction. | §01.05.C, of Art. 05 |
| Above Ground Storage Tanks | <input type="checkbox"/> | <input type="checkbox"/> | Aboveground storage tanks shall be screened utilizing walls matching the main structure. Screening plans for above ground storage tanks shall generally conform to the diagram below (i.e. incorporate primary screening – screening wall – and secondary screening) and be approved by the Planning and Zoning Commission in conjunction with a site plan. | §01.05.D, of Art. 05 |
| Dumpster Screening | <input type="checkbox"/> | <input type="checkbox"/> | Trash/Recycling enclosures shall be four (4) sided. These receptacles shall be screened by a minimum six (6) foot, solid masonry dumpster enclosure that utilizes the same masonry materials as the primary building and incorporates an opaque, self-latching gate. Dumpster storage should be located to the rear of the buildings with proper access. Trash dumpster shall not be located in any required parking space and shall allow proper access by service trucks. The minimum enclosure area shall be 12'x10'. A minimum of 6" bollards will be required at potential impact zones and the pad site shall be paved to city standards. | §01.05.B, of Art. 05 |
| Outside Storage | <input type="checkbox"/> | <input type="checkbox"/> | | |
| Off-Street Loading Dock Screening | <input type="checkbox"/> | <input type="checkbox"/> | Off-street loading docks must be screened from all public streets and any residential district that abuts or is directly across a public street or alley from the lot. The screening must be at least six feet in height and may be provided by using a masonry fence, berms, plantings or a combination of the above. | §01.05.A, of Art. 05 |
| Residential Adjacency Standards | <input type="checkbox"/> | <input type="checkbox"/> | The director may require wing walls, landscape screens, changes in building orientation, and/or other architectural elements to minimize the impact of uses adjacent to residential property within 150 feet (also reference Art. VIII 5.2). | §01.06, of Art. 05 |

3.1 LANDSCAPE PLAN

| Requirements | √= OK | N/A | Comments | UDC Reference |
|--|--------------------------|--------------------------|---|--------------------------------|
| Provide Site Data | <input type="checkbox"/> | <input type="checkbox"/> | Provide the same site data information required in Section 2.1 Site Plan: Miscellaneous and Density and Dimensional Requirements of this checklist. | See Sec. 2.1 of this checklist |
| Impervious Area vs. Landscape/Open Space Area Provided and Required (As Per Zoning District) | <input type="checkbox"/> | <input type="checkbox"/> | Indicate the applicable zoning district percentage of landscaping required and provided, and the impervious area vs. the amount of landscaping and open spaces required and provided. | §01.01.B, of Art. 05 |
| Landscape Table | <input type="checkbox"/> | <input type="checkbox"/> | Provide a landscape table showing plant materials, quantities, size and spacing for existing and proposed landscaping. Complete description of plant materials shown on the plan, including names, locations, qualities, container or caliper sizes at installation, heights, spread, and spacing requirements should also be listed on the plan. | §05.03.B, of Art. 08 |
| Indicate all Landscaping | <input type="checkbox"/> | <input type="checkbox"/> | Indicate the locations of all existing and proposed landscaping. | §05.03.B, of Art. 08 |
| Location of Water Courses and Significant Drainage Features | <input type="checkbox"/> | <input type="checkbox"/> | Indicate the locations of all existing and/or proposed water courses and the location of any existing and/or proposed significant drainage features. | - |
| Indicate all Landscape Buffers | <input type="checkbox"/> | <input type="checkbox"/> | Indicate the locations and dimensions of the required landscape buffers. | §05.01, of Art. 08 |

| Acceptable Landscape Materials: | | | Sec. 04., of Art. 08 |
|---|--------------------------|--------------------------|---|
| ✓ Trees allowed in Street Landscape Buffers | <input type="checkbox"/> | <input type="checkbox"/> | Cedar Elm, Texas Red Oak, Homestead Elm, Lace Bark Elm, Bald Cypress, Chinese Pistachio, October Glory Maple, Pecan, Texas Ash, Live Oak, Chinquapin Oak, and Burr Oak (Understory Trees: Texas Redbud, Mexican Plum, Downy Hawthorn, Wax Myrtle, Yaupon, and Deciduous Yaupon) |
| ✓ Trees not allowed in Landscape Buffers | <input type="checkbox"/> | <input type="checkbox"/> | Silver Maple, Box Elder, Mimosa, Catalpa, Hackberry, Sugarberry, Honey Locust, Tulip Tree, Chinaberry, Sycamore, Cottonwood, Willows, American Elm, Siberian Elm, Jerusalem Thorn/Petuma, Bois D'Arc, Flowering Crabapple Tree, Ginko Tree, Peach/Plum, Mulberry, Texas Mountain Laurel, Lilac Chaste Tree, and Pine Tree. |
| Protected Trees (That Will Remain On-Site) | <input type="checkbox"/> | <input type="checkbox"/> | Indicate the location and provide a description by type and size of all existing protected trees (4" or larger) proposed to be retained. Prior to any construction or land development, the developer shall clearly mark all protected and feature trees with an aluminum tag -- indicating the trees relationship to the treescape plan -- and flag (i.e. bright fluorescent red vinyl tape). In those instances where a protected tree is so close to the construction area that construction equipment could possibly damage the tree, a protective fence shall be required. |
| Parking Lot Landscaping | <input type="checkbox"/> | <input type="checkbox"/> | Complete description of landscaping and screening to be provided in or near off-street parking and loading areas, including the information as to the amount (in sq. ft.) of landscape area to be provided internal to parking areas, the total square footage included in the parking area, and the number and location of required off-street parking and loading spaces. |
| Location of all Site Amenities | <input type="checkbox"/> | <input type="checkbox"/> | Identify the size, height, location, and material of proposed seating, lighting, planter's sculptures, water features and landscape paving and other public amenities. |
| Identify Visibility Triangles | <input type="checkbox"/> | <input type="checkbox"/> | Identify visibility triangles on all lots for all driveway intersections and public streets. |
| Landscape Buffer - Street Trees | <input type="checkbox"/> | <input type="checkbox"/> | Large trees (a species which normally reaches a height of 30 feet or more upon maturity) shall be provided in the required street landscape buffer in numbers equal to one (1) tree for every 50 feet of street frontage. |
| Tree Locations | <input type="checkbox"/> | <input type="checkbox"/> | Trees must be planted at least five (5) feet from water, sewer and storm sewer lines. |
| Irrigation Requirements Note | <input type="checkbox"/> | <input type="checkbox"/> | Provide note indicating irrigation will meet requirements of UDC. |
| Hydro mulch (or non-sod option) | <input type="checkbox"/> | <input type="checkbox"/> | The developer shall establish grass and maintain the seeded area, including watering, until a "Permanent Stand of Grass" is obtained at which time the project will be accepted by the City. A "Stand of Grass" shall consist of 75% to 80% coverage and a minimum of one-inch (1") in height as determined by the City. |
| Rights-of-Way & Landscape Buffers | <input type="checkbox"/> | <input type="checkbox"/> | All landscape buffers and public right-of-way located adjacent to a proposed development shall be improved with grass (i.e. sod -- hydro mulch shall be prohibited in these areas) prior to the issuance of a Certificate of Occupancy (CO). |

4.1 TREESCAPE PLAN

| Requirements | ✓= OK | N/A | Comments | UDC Reference |
|---|--------------------------|--------------------------|--|--------------------------------|
| Provide Site Data | <input type="checkbox"/> | <input type="checkbox"/> | Provide the same site data information required in Section 2.1 <i>Site Plan: Miscellaneous and Density and Dimensional Requirements</i> of this checklist. | See Sec. 2.1 of this checklist |
| Buildings | <input type="checkbox"/> | <input type="checkbox"/> | Indicate the location of all existing or proposed structures, and/or the building pads as shown on the grading plan. | §03.01.A, of Art. 09 |
| Indicate all Site Elevations, Grades, Major Contours and the Limits of Construction | <input type="checkbox"/> | <input type="checkbox"/> | | §03.01.C, of Art. 09 |

| | | | | |
|--|--------------------------|--------------------------|---|----------------------|
| Protected Trees (To Remain On Site) | <input type="checkbox"/> | <input type="checkbox"/> | Indicate the location and provide a description by type and size of all existing protected trees (4" or larger) proposed to be retained. Such trees shall be marked and a drip line of said trees shall be protected prior to and during all construction, including dirt work. | §03.01.E, of Art. 09 |
| Protected Trees (To be Removed from the Site) | <input type="checkbox"/> | <input type="checkbox"/> | Indicate the location of all protected trees (4" or larger) that are to be removed from the site and the proposed locations of all replacement trees. | §03.01.F, of Art. 09 |
| Treescape Table | <input type="checkbox"/> | <input type="checkbox"/> | Provide a table showing the total inches of trees to be removed and the total inches of trees to be replaced. | §03.01.G, of Art. 09 |

5.1 PHOTOMETRIC AND LIGHTING PLANS

| Requirements | ✓= OK | N/A | Comments | UDC Reference |
|--|--------------------------|--------------------------|---|----------------------------------|
| Provide Site Data Table | <input type="checkbox"/> | <input type="checkbox"/> | Provide the same site data information required in Section 2.1 <i>Site Plan: Miscellaneous and Density and Dimensional Requirements</i> of this checklist. | See Sec. 2.1 of this checklist - |
| Indicate Lighting Levels (in Foot Candles [FC]) | <input type="checkbox"/> | <input type="checkbox"/> | Show lighting levels in foot-candles (FC) measured throughout the site and extended to all property lines of the subject property. | §03.03, of Art. 07 |
| Adjacent Property with Common Lot Lines: | | | | |
| ✓ Residential Use | <input type="checkbox"/> | <input type="checkbox"/> | The allowable maximum light intensity measured at the property line of a residential property shall be 0.2 of one foot candle. | §03.03.B, of Art. 07 |
| ✓ Commercial Use | <input type="checkbox"/> | <input type="checkbox"/> | The allowable maximum light intensity measured at the property line of a non-residential property shall be 0.2 of one foot candle. <i>Subject to requirements in Art. VII 3.3.C.</i> | §03.03.C, of Art. 07 |
| Under-Canopy Lighting | <input type="checkbox"/> | <input type="checkbox"/> | Under canopy lighting (i.e. fuel stations, drive through lanes and covered parking structures) shall not exceed 35 foot candles (with the exception below). | §03.03.E.1, of Art. 07 |
| Lighting for Motor Vehicle Dealerships | <input type="checkbox"/> | <input type="checkbox"/> | Shall not exceed 0.3 of one foot candle within the front yard of the development. The remainder will comply with the 0.2 of one foot candle. | §03.03.E.2, of Art. 07 |
| Lighting in Parking Areas | <input type="checkbox"/> | <input type="checkbox"/> | The maximum outdoor maintained, computed and measured illumination level within any nonresidential development shall not exceed 20 FC outdoors at any point on the site, with a maximum of 0.2 FC at the property line. (Exceptions: (1) under canopy lighting and (2) motor vehicle dealerships) | §03.03.G, of Art. 07 |
| Building and Pole Mounted Lighting | <input type="checkbox"/> | <input type="checkbox"/> | Indicate the location and type of all exterior lighting, including pole mounted, wall-mounted, signage, etc. | §03.03.E, of Art. 07 |
| Indicate the Mounting Height for all Proposed Light Fixtures | <input type="checkbox"/> | <input type="checkbox"/> | No light pole, base or combination thereof shall exceed 30 feet, unless further restricted within an Overlay District. | §03.03.D of Art. 07 |
| Indicate the Wattage of all Light Sources | <input type="checkbox"/> | <input type="checkbox"/> | Provide lighting cut sheets that indicates the wattage for each exterior lighting fixture. Light sources (e.g. light bulbs) shall be oriented down and toward the center of the site or shielded so as to not be visible from the property line. | §03.03.A, of Art. 07 |
| Proposed Light Fixtures | <input type="checkbox"/> | <input type="checkbox"/> | Provide elevation drawings and/or cut-sheets of proposed light fixtures on/with photometric plan. | §03.03, of Art. 07 |

6.1 BUILDING ELEVATIONS: NON-INDUSTRIAL

| Requirements | ✓= OK | N/A | Comments | UDC Reference |
|--|--------------------------|--------------------------|--|----------------------|
| Provide Exterior Elevations | <input type="checkbox"/> | <input type="checkbox"/> | <u>North</u> <u>South</u> <u>East</u> <u>West</u> (Circle all that apply) | - |
| Indicate Exterior Elevations Adjacent to Public Right-of-Way | <input type="checkbox"/> | <input type="checkbox"/> | <u>North</u> <u>South</u> <u>East</u> <u>West</u> (Circle all that apply) | - |
| Minimum 90% Masonry Requirement <i>OVERLAY DISTRICTS ONLY</i> | <input type="checkbox"/> | <input type="checkbox"/> | Exterior walls should consist of 90% masonry materials excluding doors and windows. | §06.02.C, of Art. 05 |
| Indicate Amount and Location of the Minimum 20% Stone Requirement <i>OVERLAY DISTRICTS ONLY</i> | <input type="checkbox"/> | <input type="checkbox"/> | Applies to facades that are visible from a public right-of-way and/or open space. | §06.02.C, of Art. 05 |
| Indicate the Surface Area of Each Facade | <input type="checkbox"/> | <input type="checkbox"/> | Indicate the surface area (square feet) of each façade and the percentage and square footage of each material used on that façade. | §04.01, of Art. 05 |
| Proposed Building Materials | <input type="checkbox"/> | <input type="checkbox"/> | Specifications and description of all proposed building materials, on all proposed buildings. | §04.01, of Art. 05 |
| Indicate the Roofing Materials and Color | <input type="checkbox"/> | <input type="checkbox"/> | | |

| | | | | |
|---|--------------------------|--------------------------|--|------------------------|
| Indicate Parapet Wall Height **(If Applicable, finish the interior side of the parapet wall) | <input type="checkbox"/> | <input type="checkbox"/> | If applicable indicate the parapet wall by dashing in the top of roof deck. **Projecting elements and parapets that are visible from adjacent properties or public right-of-way shall be finished on the interior side using the same materials as the exterior facing wall. | §04.01, of Art. 05 |
| Indicate all Roof Mounted Mechanical Equipment (If Applicable) | <input type="checkbox"/> | <input type="checkbox"/> | If applicable indicate any proposed roof mounted mechanical equipment and indicate how these will be screened from view. | §01.05.C, of Art. 05 |
| Indicate Any Additional Design Elements Proposed (If Applicable) | <input type="checkbox"/> | <input type="checkbox"/> | Indicate any additional design elements for the base, walls, or parapets (such as cornice, arcades, and covered walkways/windows). Be sure to include the location, size, color, and material of any proposed structure. | |
| Indicate Building Height(s) | <input type="checkbox"/> | <input type="checkbox"/> | The height of the building shall be measured from the average elevation of the finished grade along the front of the building to the highest point of the roof or parapet of the building if it is a flat, mansard or shed roof; or to the midpoint of the roof if it is gable, hip or gambrel roof. | §07.03 of Art. 05 |
| Minimum Standards for Articulation: | | | | |
| Primary Facades (i.e. facades visible from a public ROW, open space/green space, public/private park, and or residential zoning district or residentially used property) | <input type="checkbox"/> | <input type="checkbox"/> | 1. Wall Height [H] = H 2. Wall Length [L] = 3 x H 3. Secondary Entry/Arch. Element Length = 25% x L 4. Wall Projection = 25% x H 5. Primary Entry/Arch. Element Width = 2 x (25% x L) 6. Projection Height = 25% x H 7. Primary Entry/Arch. Element Length = 2 x (25% x L) | §04.01.C.1, of Art. 05 |
| Secondary Facades | <input type="checkbox"/> | <input type="checkbox"/> | 1. Wall Height [H] = H 2. Wall Length [L] = 3 x H 3. Secondary Entry/Arch. Element Length = 15% x L 4. Secondary Entry/Arch. Element Width = 15% x H 5. Projection Height = 15% x H | §04.01.C.2, of Art. 05 |

6.2 BUILDING ELEVATIONS: INDUSTRIAL

| Requirements | ✓ = OK | N/A | Comments | UDC Reference |
|---|--------------------------|--------------------------|---|----------------------------|
| NOTE: Industrial buildings are subject to all the elements listed in Section 6.1 Building Elevations: Non-Industrial with the exception of the following standards. | | | | |
| Minimum 90% Masonry Requirement | <input type="checkbox"/> | <input type="checkbox"/> | Exterior walls should consist of 90% masonry materials excluding doors and windows. | §05.01.A.1, of Art. 05 |
| Indicate Amount and Location of the Minimum 20% Stone Requirement | <input type="checkbox"/> | <input type="checkbox"/> | Applies to facades that are visible from a public right-of-way and/or open space. | §05.01.A.1.a.1, of Art. 05 |
| Minimum Standards for Articulation: | | | | |
| Primary Facades (i.e. facades visible from a public ROW, open space/green space, public/private park, and or residential zoning district or residentially used property) | <input type="checkbox"/> | <input type="checkbox"/> | 1. Wall Height [H] = H 2. Wall Length [L] = 4 x H 3. Wall Projection = 25% x H 4. Entry/Arch. Element Length = 33% x L 5. Projection Height = 25% x H 6. Entry/Arch. Element Width = 2 x (25% x H) | §05.01.C.1, of Art. 05 |
| Secondary Facades | <input type="checkbox"/> | <input type="checkbox"/> | 1. Wall Height [H] = H 2. Wall Length [L] = 3 x H 3. Entry/Arch. Element Length = 15% x L 4. Entry/Arch. Element Width = 15% x H 5. Projection Height = 15% x H | §05.01.C.2, of Art. 05 |