



# DEVELOPMENT APPLICATION

City of Rockwall  
Planning and Zoning Department  
385 S. Goliad Street  
Rockwall, Texas 75087

STAFF USE ONLY

PLANNING & ZONING CASE NO.

**NOTE: THE APPLICATION IS NOT CONSIDERED ACCEPTED BY THE CITY UNTIL THE PLANNING DIRECTOR AND CITY ENGINEER HAVE SIGNED BELOW.**

DIRECTOR OF PLANNING:

CITY ENGINEER:

PLEASE CHECK THE APPROPRIATE BOX BELOW TO INDICATE THE TYPE OF DEVELOPMENT REQUEST (SELECT ONLY ONE BOX):

### PLATTING APPLICATION FEES:

- MASTER PLAT (\$100.00 + \$15.00 ACRE)<sup>1</sup>
- PRELIMINARY PLAT (\$200.00 + \$15.00 ACRE)<sup>1</sup>
- FINAL PLAT (\$300.00 + \$20.00 ACRE)<sup>1</sup>
- REPLAT (\$300.00 + \$20.00 ACRE)<sup>1</sup>
- AMENDING OR MINOR PLAT (\$150.00)
- PLAT REINSTATEMENT REQUEST (\$100.00)

### SITE PLAN APPLICATION FEES:

- SITE PLAN (\$250.00 + \$20.00 ACRE)<sup>1</sup>
- AMENDED SITE PLAN/ELEVATIONS/LANDSCAPING PLAN (\$100.00)

### ZONING APPLICATION FEES:

- ZONING CHANGE (\$200.00 + \$15.00 ACRE)<sup>1</sup>
- SPECIFIC USE PERMIT (\$200.00 + \$15.00 ACRE)<sup>1 & 2</sup>
- PD DEVELOPMENT PLANS (\$200.00 + \$15.00 ACRE)<sup>1</sup>

### OTHER APPLICATION FEES:

- TREE REMOVAL (\$75.00)
- VARIANCE REQUEST/SPECIAL EXCEPTIONS (\$100.00)<sup>2</sup>

### NOTES:

<sup>1</sup>: IN DETERMINING THE FEE, PLEASE USE THE EXACT ACREAGE WHEN MULTIPLYING BY THE PER ACRE AMOUNT. FOR REQUESTS ON LESS THAN ONE ACRE, ROUND UP TO ONE (1) ACRE.  
<sup>2</sup>: A \$1,000.00 FEE WILL BE ADDED TO THE APPLICATION FEE FOR ANY REQUEST THAT INVOLVES CONSTRUCTION WITHOUT OR NOT IN COMPLIANCE TO AN APPROVED BUILDING PERMIT.

## PROPERTY INFORMATION [PLEASE PRINT]

ADDRESS 2852 FM 1141 Rockwall, Tx 75087

SUBDIVISION Rockwall High School 9th Grade Center LOT 1 BLOCK 1

GENERAL LOCATION at the northwest corner of Quail Run Road and FM 1141

## ZONING, SITE PLAN AND PLATTING INFORMATION [PLEASE PRINT]

CURRENT ZONING AG CURRENT USE PUBLIC SCHOOL

PROPOSED ZONING NEIGHBORHOOD SERVICES PROPOSED USE PUBLIC SCHOOL

ACREAGE 76 LOTS [CURRENT] 1 LOTS [PROPOSED] 1

- SITE PLANS AND PLATS:** BY CHECKING THIS BOX YOU ACKNOWLEDGE THAT DUE TO THE PASSAGE OF HB3167 THE CITY NO LONGER HAS FLEXIBILITY WITH REGARD TO ITS APPROVAL PROCESS, AND FAILURE TO ADDRESS ANY OF STAFF'S COMMENTS BY THE DATE PROVIDED ON THE DEVELOPMENT CALENDAR WILL RESULT IN THE DENIAL OF YOUR CASE.

## OWNER/APPLICANT/AGENT INFORMATION [PLEASE PRINT/CHECK THE PRIMARY CONTACT/ORIGINAL SIGNATURES ARE REQUIRED]

OWNER Rockwall Independent School District  APPLICANT Glenn Engineering Corp.

CONTACT PERSON William Salee - Executive Director of Operations CONTACT PERSON Robert Howman

ADDRESS 1191 T.L. Townsend Drive ADDRESS 4500 Fuller Drive

Suite 220

CITY, STATE & ZIP Rockwall, Texas 75087 CITY, STATE & ZIP Irving, Texas 75038

PHONE 469-698-7031 PHONE 972-989-2174 cell

E-MAIL will.salee@rockwallisd.org E-MAIL rahowman@glennengineering.com

## NOTARY VERIFICATION [REQUIRED]

BEFORE ME, THE UNDERSIGNED AUTHORITY, ON THIS DAY PERSONALLY APPEARED Will Salee [OWNER] THE UNDERSIGNED, WHO STATED THE INFORMATION ON THIS APPLICATION TO BE TRUE AND CERTIFIED THE FOLLOWING:

"I HEREBY CERTIFY THAT I AM THE OWNER FOR THE PURPOSE OF THIS APPLICATION; ALL INFORMATION SUBMITTED HEREIN IS TRUE AND CORRECT; AND THE APPLICATION FEE OF \$ 100.00 TO COVER THE COST OF THIS APPLICATION, HAS BEEN PAID TO THE CITY OF ROCKWALL ON THIS THE 19th DAY OF August, 2022 BY SIGNING THIS APPLICATION. I AGREE THAT THE CITY OF ROCKWALL (I.E. "CITY") IS AUTHORIZED AND PERMITTED TO PROVIDE INFORMATION CONTAINED WITHIN THIS APPLICATION TO THE PUBLIC. THE CITY IS ALSO AUTHORIZED AND PERMITTED TO REPRODUCE ANY COPYRIGHTED INFORMATION SUBMITTED IN CONJUNCTION WITH THIS APPLICATION, IF SUCH REPRODUCTION IS ASSOCIATED OR IN RESPONSE TO A REQUEST FOR PUBLIC INFORMATION."

GIVEN UNDER MY HAND AND SEAL OF OFFICE ON THIS THE 19th DAY OF August, 2022

OWNER'S SIGNATURE

NOTARY PUBLIC IN AND FOR THE STATE OF TEXAS

*Will Salee*  
*Diana Chapman*

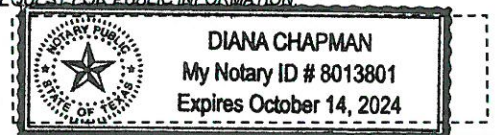

MY COMMISSION EXPIRES

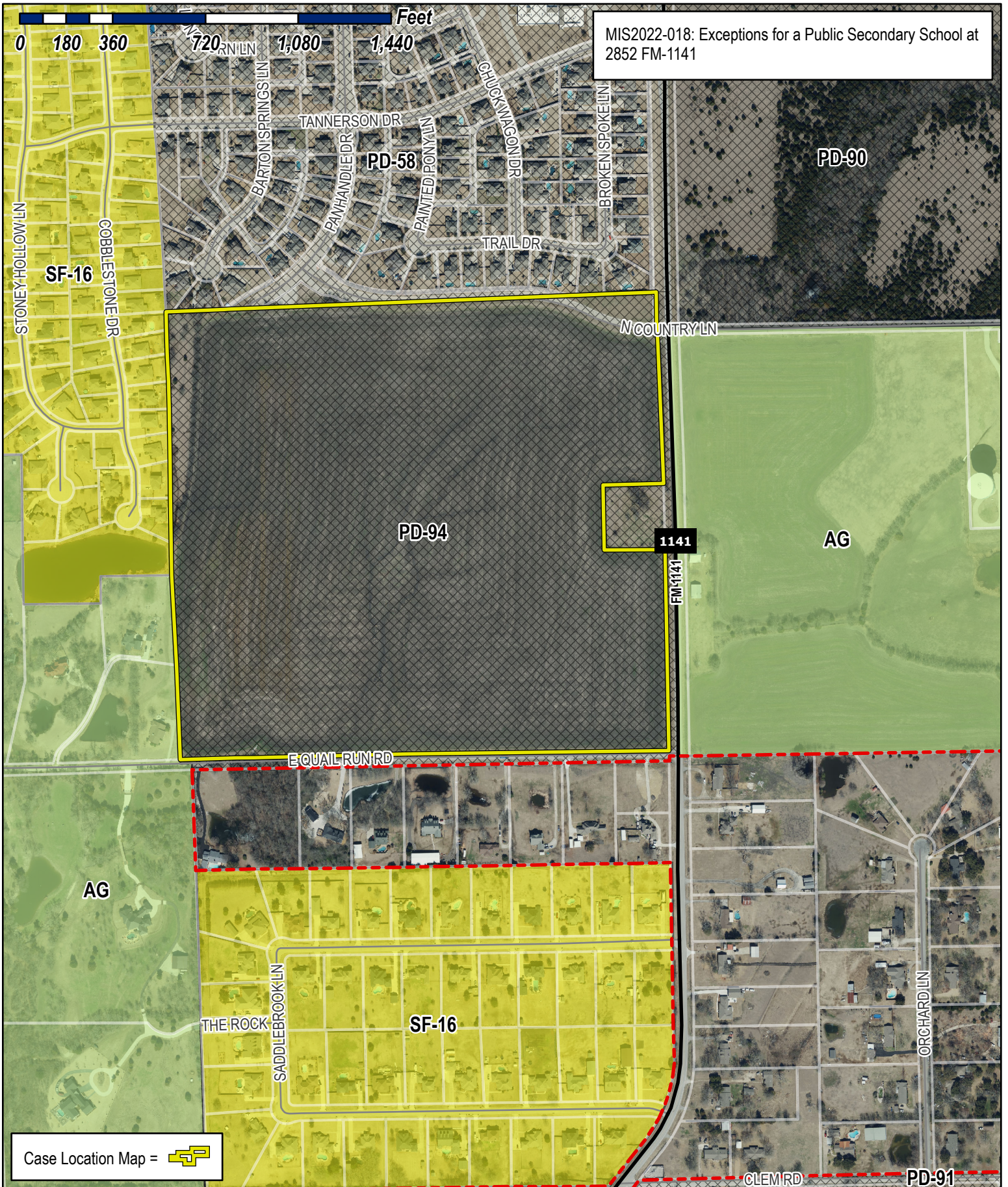

MIS2022-018: Exceptions for a Public Secondary School at 2852 FM-1141

Case Location Map = 



# City of Rockwall

Planning & Zoning Department  
 385 S. Goliad Street  
 Rockwall, Texas 75032  
 (P): (972) 771-7745  
 (W): www.rockwall.com

The City of Rockwall GIS maps are continually under development and therefore subject to change without notice. While we endeavor to provide timely and accurate information, we make no guarantees. The City of Rockwall makes no warranty, express or implied, including warranties of merchantability and fitness for a particular purpose. Use of the information is the sole responsibility of the user.





August 19, 2022

Ryan Miller  
Director of Planning  
City of Rockwall  
385 South Goliad  
Rockwall, TX 75087

**Rockwall ISD – Updated Site Plans for Ninth Grade Center Projects:  
SP 2022-17 (FM1141& Quail Run) & SP2022-18 (John King Blvd at GBCCA)**

Mr. Miller,

Per recent site plan approval for the above referenced projects on July 12, 2022 by the Planning & Zoning Commission, there were the following conditional approval items noted by the city staff that are to be addressed related to landscape plan requirements and sports field/court lighting:

North Site:

- (1) *The applicant will need to provide an updated Landscape Plan showing landscaping along the right-of-way of Panhandle Drive (i.e. berms and shrubbery with a minimum of one [1] canopy tree and one [1] accent tree per 50-feet of linear frontage). In addition, the Landscape Plan should show one (1) canopy tree per 750 SF of detention area and one (1) accent tree per 1,500 SF of detention area.*
- (2) *The applicant must request an exception for any light pole greater than 30'-0" in height per Subsection 03.03.D, of Article 07*

South Site:

- (1) *The applicant will need to provide an updated Landscape Plan showing one (1) canopy tree per 750 SF of detention area and one (1) accent tree per 1,500 SF of detention area.*
- (2) *The applicant must request an exception for any light pole greater than 30'-0" in height per Subsection 03.03.D, of Article 07*

Rockwall ISD is submitting updated landscape plans showing the number and location of proposed trees to include in regards to the detention areas. The North plan submitted with this letter includes the required landscaping along the Panhandle Drive right of way as required.

**Landscape Plan – Detention Areas**

Rockwall ISD is requesting a partial variance for consideration by the Planning & Zoning Commission. The space available around the perimeter of the detention pond is limited due to the required location on the site for these detention areas. At both sites, 3-tiered screening elements are adjacent to the detention areas limiting the amount of trees that can feasibly fit around and near the detention basin. Forcing trees in this area will create a scenario where tree canopy growth will inhibit any ground cover, reduce tree health, and increase the likelihood of erosion due to the lack of groundcover. All other required trees for the 3-tier screening and required parking lot trees are shown to be provided and we will be in compliance. As a result, the district is asking for the following variance:

*Approval to disperse throughout the site as many of the required detention canopy and accent trees in open areas possible that are not reserved for future potential building expansions and in a manner that will not create a hazard, nuisance or erosion issue. Once those spaces are exhausted we propose to then omit the following numbers of trees per site:*



### **North Site:**

Number of Required Detention Trees: (155) Number of trees proposed to be planted: (101)  
Omit (36) Canopy Trees & (18) Accent Trees related to detention area requirements.  
Approximate percentage of detention trees requesting to omit: (35%)

Other Required Trees to be planted:

- 3-Tier Screening Trees (162) Canopy Trees & (245) Accent Trees: (407) Total for Screening
- Required Trees at Parking Areas: (39) Canopy Trees

**Total Number of Trees to be planted if variance is approved: (547) Total North Site Trees**

### **South Site:**

Number of Required Detention Trees: (198) Number of trees proposed to be planted: (132)  
Omit (43) Canopy Trees & (23) Accent Trees related to detention area requirements.  
Approximate percentage of detention trees requesting to omit: (35%)

Other Required Trees to be planted:

- 3-Tier Screening Trees (234) Canopy Trees & (70) Accent Trees: (304) Total for Screening
- Required Trees at Parking Areas: (53) Canopy Trees

**Total Number of Trees to be planted if variance is approved: (489) Total South Site Trees**

In lieu of investing resources in dispersed trees that do not serve the purpose of beautifying the detention area and would have to be removed in the future, the district would like to direct those resources to beautifying and creating community accessible amenities for the detention areas in the following ways as an alternate compliance method for consideration:

1. Create a Wet Pond - In lieu of a dry detention basin, the district would propose to make these a constant level wet retention pond while still functioning to detain runoff as required.
  - a. The pond would include an aeration fountain element
  - b. The pond would include circulation plumbing to minimize algae growth
  - c. The pond will have an organic shape and have a flagstone border
  - d. The district would utilize HVAC condensate collection to fill the pond in hot, humid summer & spring seasons where pond evaporation is the greatest.
2. Create Park Amenities -The district would create a park area that is accessible to the community off the adjacent thoroughfare (John King – South & Quail Run Road – North) from the required 10-foot wide walk pathways at both locations.
  - a. Please refer the provided rendered images of park areas for proposed aesthetics
  - b. Park area will include 10' meandering pathways to pond overlook areas
  - c. Park area will include multiple park bench seating areas off of walkways
  - d. Park area will include landscape boulders within park area as an enhanced landscape feature to reinforce a more natural park setting.

This alternative method proposed to beautify the pond would transform an otherwise unattractive drainage area on both sites to a park amenity that can be utilized by both the school district and the community and will ensure resources expended provide permanent beautification elements to the site. Rockwall ISD requests acceptance of this variance and the alternate compliance method in lieu of planting the partial amount of trees requested to be omitted at each site.



### **Sports Field Lighting – Exception Request**

Per the above referenced comment, Rockwall ISD is requesting the following exceptions to install sports field lighting as necessary for utilization by the campus when daylight levels are not adequate for practice and game events:

1. Tennis Court Lighting – 40' above tennis court surface
2. Baseball Field Lighting – 70' above baseball field surface
3. Football/Soccer Field Lighting – 80' above field surface

Sports field lighting product data and photometric data are included in this request for review. All parking lot lighting at both site locations will be 25' above adjacent parking surfaces and be in compliance. The need for this exception request is to ensure light levels are adequate for these sports fields/courts for playability and safety.

The following mitigation items are proposed to be implemented:

1. Implementation of 3-tier landscape screening as required by City of Rockwall.
2. Intentional site location of fields on the property to minimize adjacency to the densest residential areas as possible as discussed in previous P&Z meetings.
3. Use of current LED sports field technology that allows LED lamps to be screened and focused on the play fields with minimal light spread beyond the field area.
4. Sports field/court lighting will be controlled by the district's energy management system. This will require users to make reservations to turn lights on and create the ability to have lockout times when lights cannot be used and the ability to turn off the fixtures remotely if required.

Rockwall ISD requests acceptance of the requested light pole height exceptions as proposed to ensure adequate playability of and safety of the field use.

I look forward to attending the Planning & Zoning Commission in person on August 30<sup>th</sup> to provide a presentation and address any questions the commission may have in regards to the districts proposed requests.

Sincerely,

A handwritten signature in blue ink, appearing to read 'Will Salee', is written over a light blue horizontal line.

Will Salee  
Executive Director of Operations

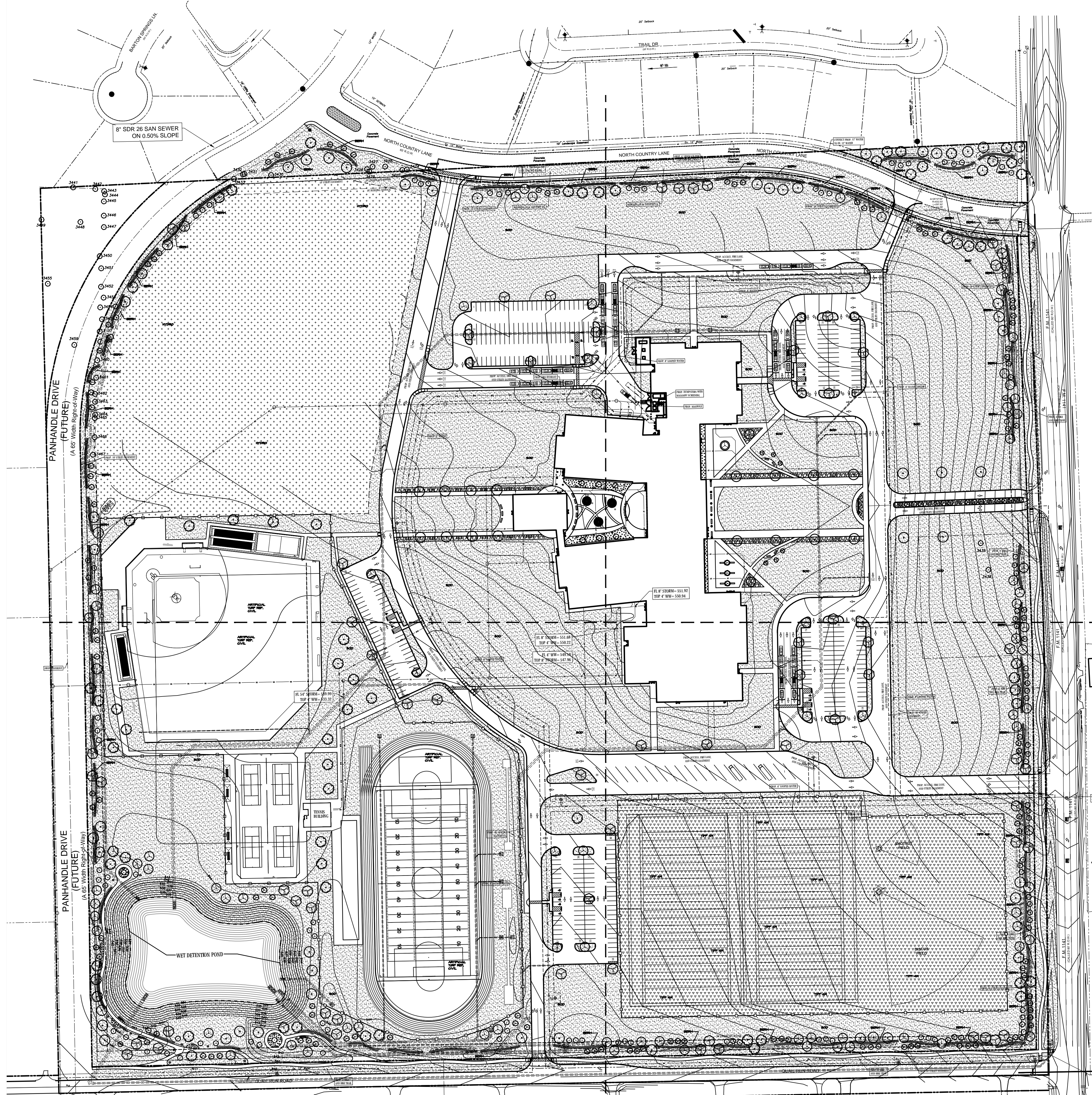

L5

L2

L4

L3

SITE DATA SUMMARY	
EXISTING ZONING	AG
PROPOSED ZONING	PB FOR NS USES (22022-015)
USE	PUBLIC SCHOOL
LOT AREA	3,044.079 S.F. OR 69.88 AC.
BUILDING AREA (FLOOR AREA)	
PROPOSED FIRST FLOOR	150,170 S.F.
PROPOSED SECOND FLOOR	41,019 S.F.
TOTAL BUILDING AREA	191,189 S.F.
TOTAL FLOOR AREA (FIRST FLOOR)	150,170 S.F.
LOT COVERAGE	5.00%
FLOOR AREA RATIO	0.05:1
TOTAL IMPERVIOUS AREA	731,645.08 S.F. OR 24.04 AC.
BUILDING HEIGHT	137' 10" (2 STORIES)
TOTAL REQUIRED PARKING (1 PER 5 STUDENTS)	205 SPACES
PARKING PROVIDED	
PARKING SURFACE	
9.0x18.0'	202 SPACES
9.0x20.0'	158 SPACES
15.0x30.0'	20 SPACES
TOTAL PARKING PROVIDED	381 SPACES

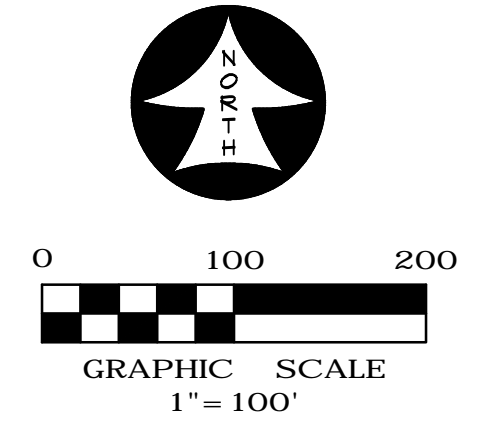

APPROVED:  
I hereby certify that the above and foregoing site plan for a development in the City of Rockwall, Texas, was approved by the Planning & Zoning Commission of the City of Rockwall on the [DAY] day of [MONTH], [YEAR].  
WITNESS OUR HANDS, this [DAY] day of [MONTH], [YEAR].

Planning & Zoning Commission, Chairman      Director of Planning and Zoning

**ROCKWALL - NINTH GRADE CENTER**  
**LOT 1, BLOCK A**  
OUT OF THE  
JOHN M. GASS SURVEY, ABSTRACT NO. 88  
CITY OF ROCKWALL, ROCKWALL COUNTY, TEXAS

OWNER/DEVELOPER:  
ROCKWALL ISD  
801 E. WASHINGTON ST.  
ROCKWALL, TEXAS 75087  
(972) 771-0605  
CONTACT: JAMES WATSON

SURVEYOR:  
BOWMAN  
1200 W. MAGNOLIA BLVD.  
SUITE 300  
FORT WORTH, TEXAS 76104  
(214) 484-8586  
CONTACT: ROBERT HANSEN

ENGINEER:  
GLENN ENGINEERING CORP.  
4500 FULLER DR.  
IRVING, TEXAS 75038  
(972) 717-5151  
CONTACT: CHERALYN M. ARMISTEAD

CITY OF ROCKWALL CASE NO. SP2022-017

**CORGAN**

401 N. Houston St  
Dallas, TX 75202  
T: 214-748-2000

ISSUES		
1	05/11/22	30% PROGRESS SET
2	07/06/22	60% PROGRESS SET
3	08/04/22	90% PROGRESS SET
4	08/16/22	95% PROGRESS SET
5		
6		

REVISIONS		

THIS DOCUMENT IS RELEASED FOR PERMIT REVIEW UNDER THE AUTHORITY OF: MICHAEL RAMSEY REGISTERED LANDSCAPE ARCHITECT #1901. IT IS NOT TO BE USED FOR CONSTRUCTION PURPOSES.

**RAMSEY LANDSCAPE ARCHITECTS, L.L.C.**  
11914 WISHING WELL CT.  
FRISCO, TEXAS 75035  
PHONE (972) 335-0889  
FAX (469) 362-5433  
EMAIL: MIKE.RL@ATT.NET

**NINTH GRADE CENERS**  
- North Site  
for  
Rockwall Independent School district  
2852 FM 1141 Rockwall, TX 75087

**OVERALL LANDSCAPE PLAN**

**JOB** 21572.0000  
**DATE** 08/16/22  
**SHEET** L 1

**ISSUES**

1	05/11/22	30% PROGRESS SET
2	07/06/22	60% PROGRESS SET
3	08/04/22	90% PROGRESS SET
4	08/16/22	95% PROGRESS SET
5		
6		

**REVISIONS**

THIS DOCUMENT IS RELEASED FOR PERMIT REVIEW UNDER THE AUTHORITY OF: MICHAEL RAMSEY REGISTERED LANDSCAPE ARCHITECT #1901. IT IS NOT TO BE USED FOR CONSTRUCTION PURPOSES.

**RAMSEY LANDSCAPE ARCHITECTS, LLC**

11914 WISHING WELL CT.  
FRISCO, TEXAS 75035  
PHONE (972) 335-0889  
FAX (469) 362-5433  
EMAIL: MIKE.RL@ATT.NET

**NINTH GRADE CENERS**

- North Site  
for  
Rockwall Independent School district  
2852 FM 1141 Rockwall, TX 75087

**LANDSCAPE PLAN AREA C**

**JOB** 21572.0000  
**DATE** 08/16/22  
**SHEET**

MATCHLINE SEE SHEET L3

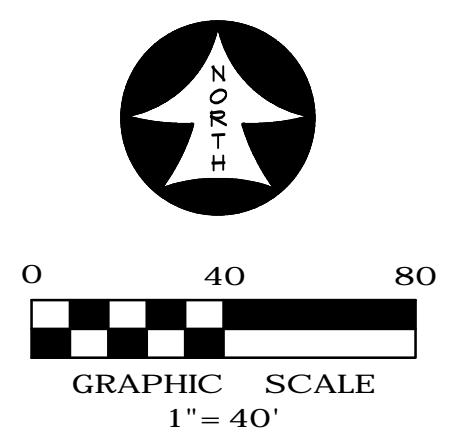
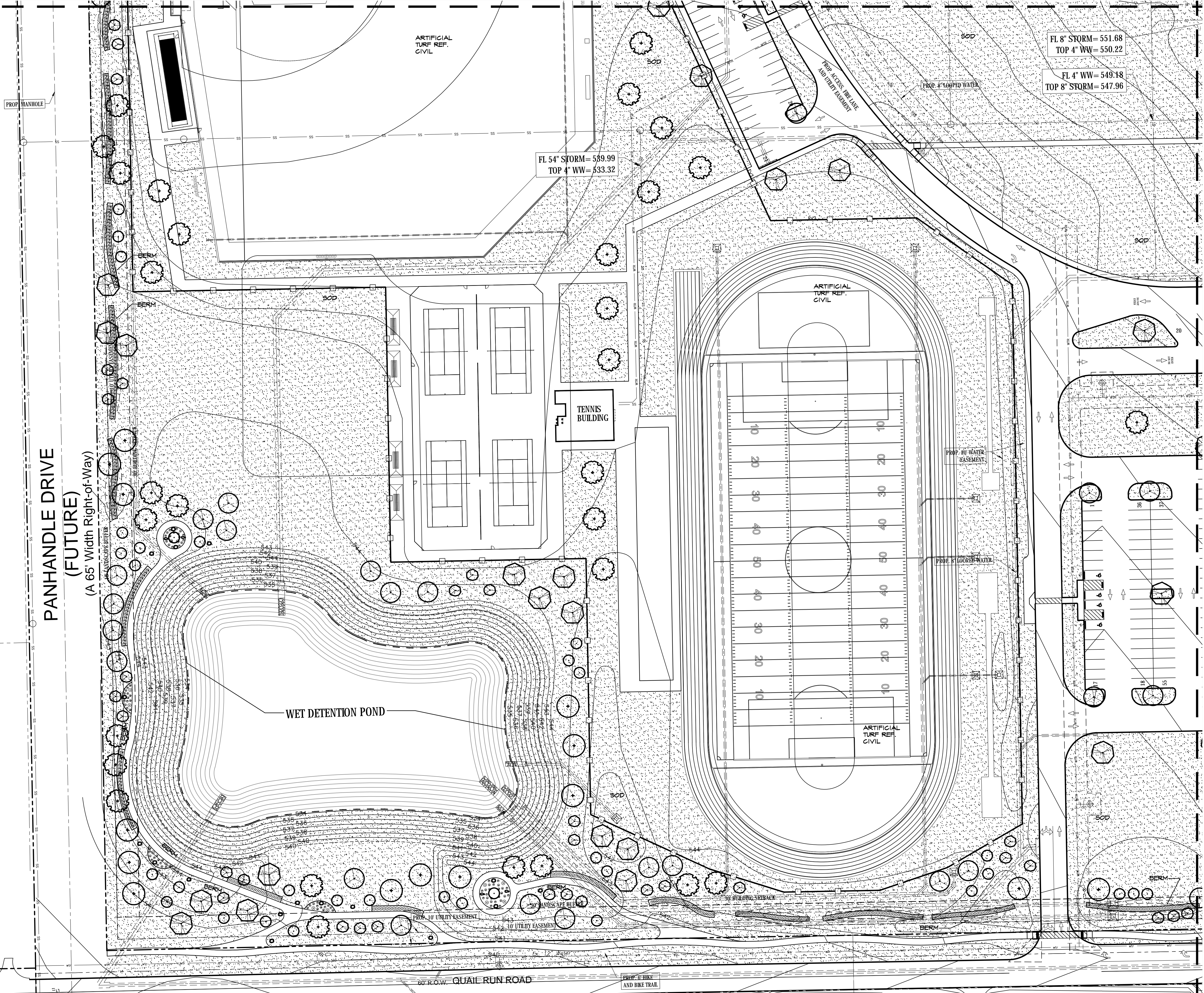

APPROVED: I hereby certify that the above and foregoing site plan for a development in the City of Rockwall, Texas, was approved by the Planning & Zoning Commission of the City of Rockwall on the [ ] day of [ ] [ ] [ ]. WITNESS OUR HANDS, this [DAY] day of [MONTH], [YEAR].

Planning & Zoning Commission, Chairman

Director of Planning and Zoning

**ROCKWALL - NINTH GRADE CENTER**

**LOT 1, BLOCK A**

**OUT OF THE**

**JOHN M. GASS SURVEY, ABSTRACT NO. 88**  
**CITY OF ROCKWALL, ROCKWALL COUNTY, TEXAS**

**OWNER/DEVELOPER:**  
ROCKWALL ISD  
801 E. WASHINGTON ST.  
ROCKWALL, TEXAS 75087  
(972) 771-0605  
CONTACT: JAMES WATSON

**ENGINEER:**  
GLEN ENGINEERING CORP.  
4500 FULLER DR.  
IRVING, TEXAS 75038  
(972) 717-5151  
CONTACT: CHERALYN M. ARMDO

**SURVEYOR:**  
BOWMAN  
1200 W. MAGNOLIA BLVD.  
SUITE 300  
FORT WORTH, TEXAS 76104  
(214) 484-8586  
CONTACT: ROBERT HANSEN





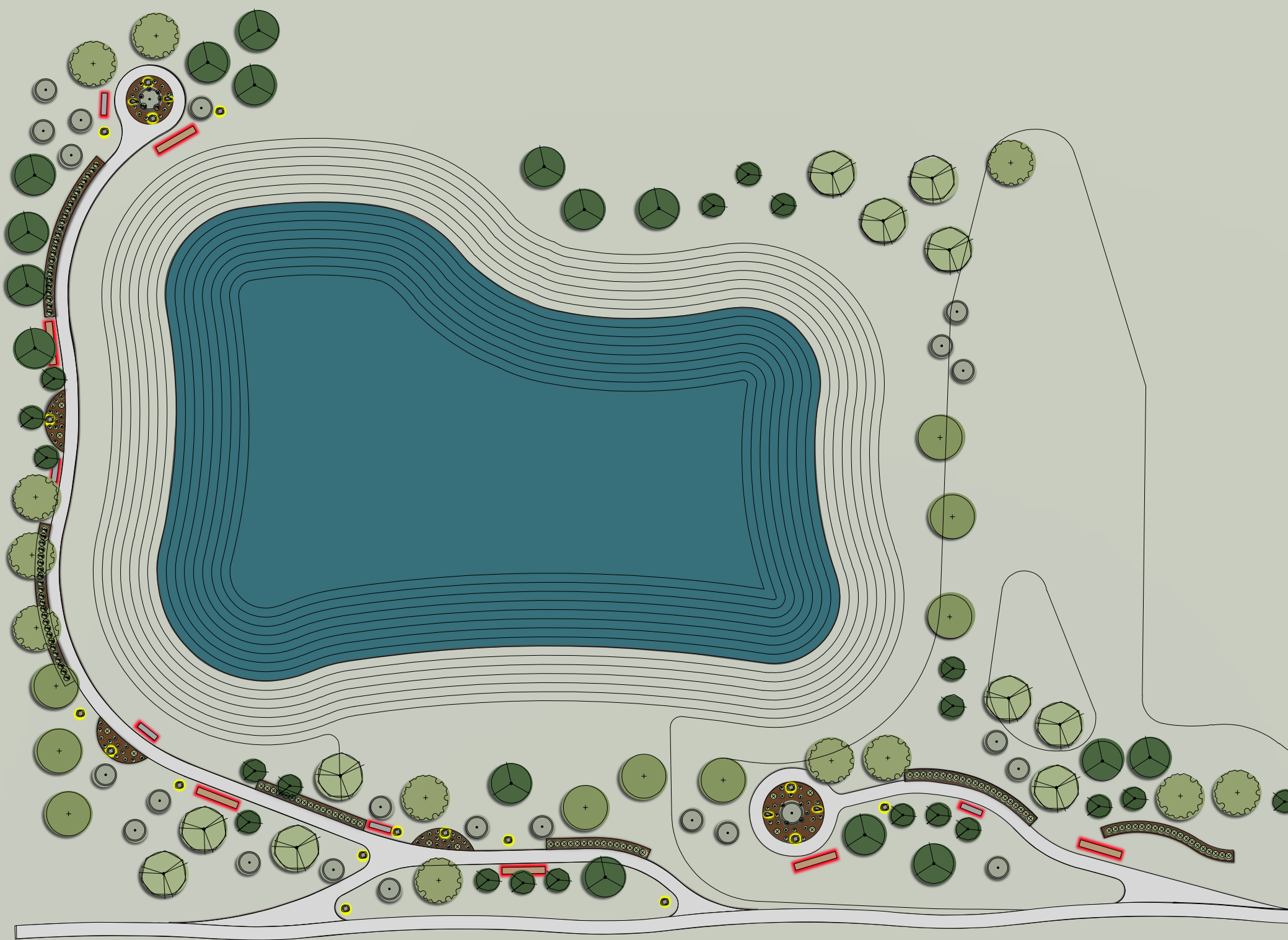





EQUIPMENT LIST FOR AREAS SHOWN							
Pole				Luminaires			
QTY	LOCATION	SIZE	GRADE ELEVATION	MOUNTING HEIGHT	LUMINAIRE TYPE	QTY / POLE	THIS GRID
4	F1-F4	80'	-	15.5'	TLC-BT-575	2	2
				80'	TLC-LED-1500	7	7
4	TOTALS					36	36

GRID SUMMARY	
Name:	Football
Size:	360' x 160'
Spacing:	30.0' x 30.0'
Height:	3.0' above grade
ILLUMINATION SUMMARY	
MAINTAINED HORIZONTAL FOOTCANDLES	
Entire Grid	
Guaranteed Average:	30
Scan Average:	35.95
Maximum:	43
Minimum:	31
Avg / Min:	1.17
Guaranteed Max / Min:	2.5
Max / Min:	1.40
UG (adjacent pts):	1.17
CU:	0.47
No. of Points:	72
LUMINAIRE INFORMATION	
Applied Circuits:	A
No. of Luminaires:	36
Total Load:	44.64 kW

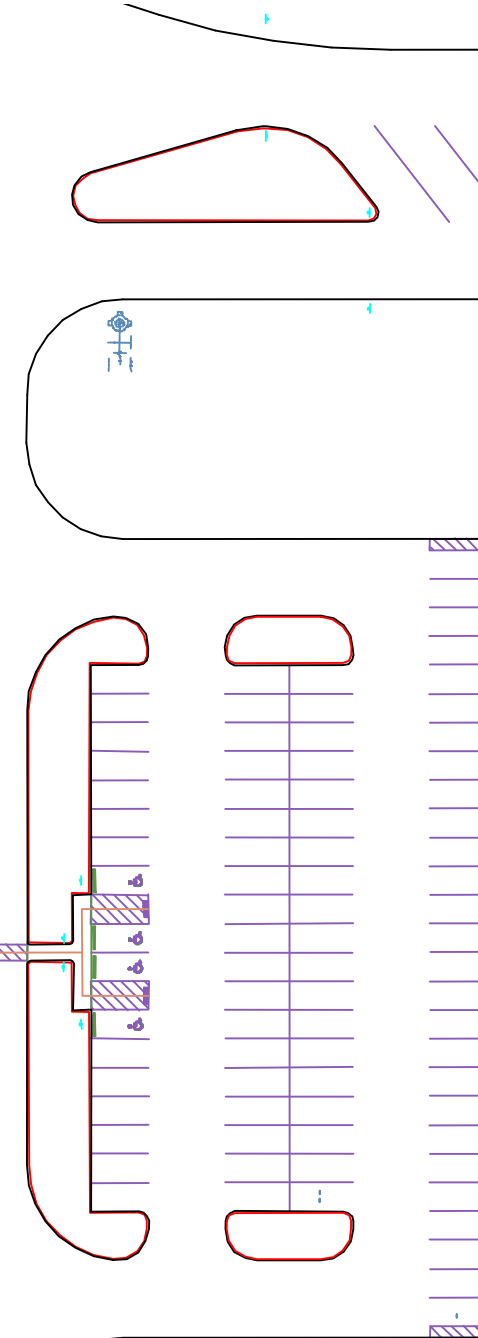
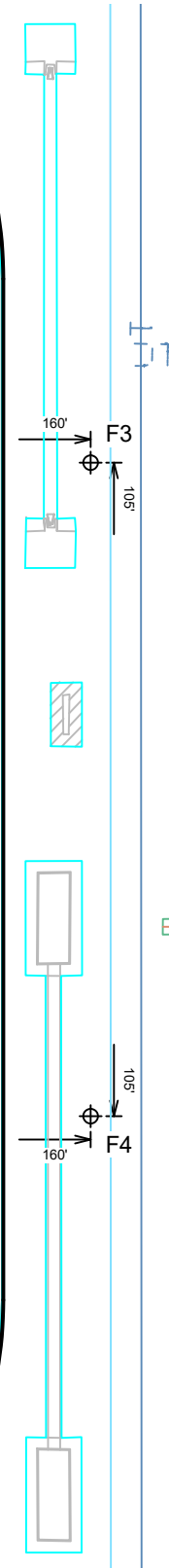
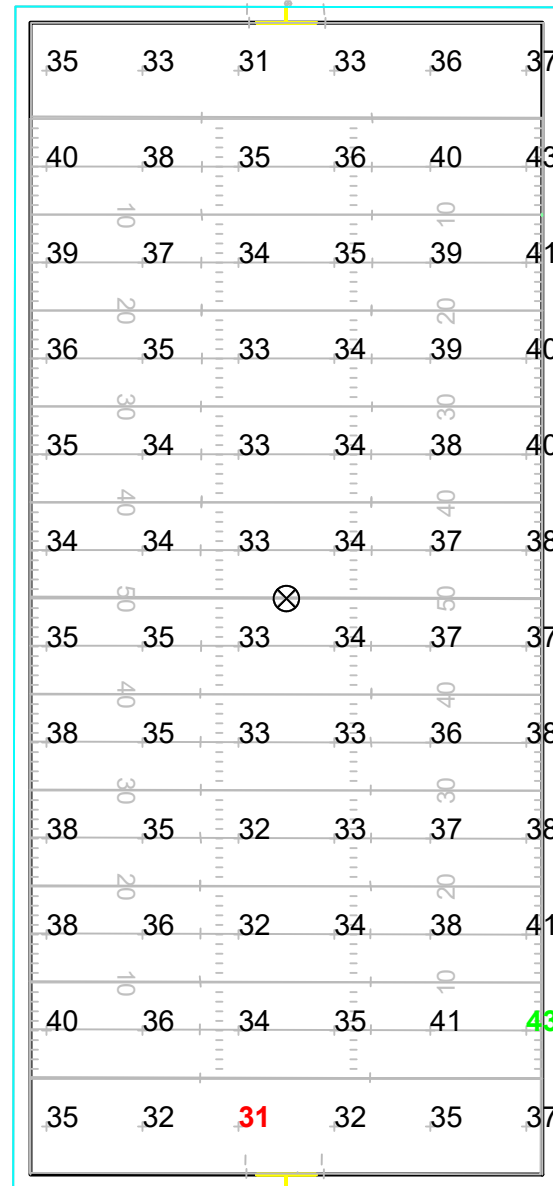
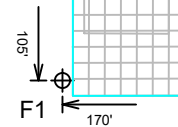
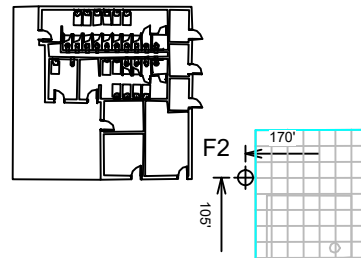
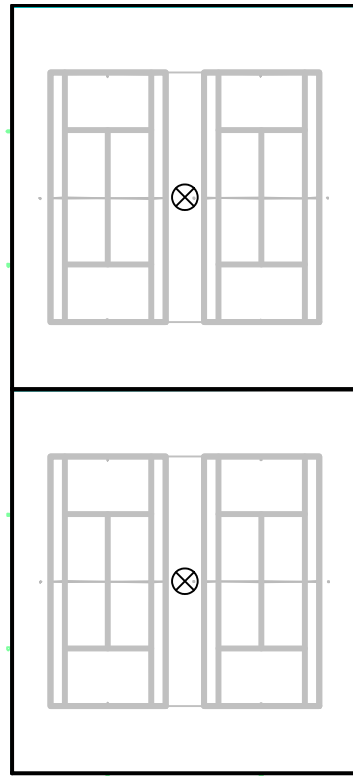

**Guaranteed Performance:** The ILLUMINATION described above is guaranteed per your Musco Warranty document and includes a 0.95 dirt depreciation factor.

**Field Measurements:** Individual field measurements may vary from computer-calculated predictions and should be taken in accordance with IESNA RP-6-15.

**Electrical System Requirements:** Refer to Amperage Draw Chart and/or the "Musco Control System Summary" for electrical sizing.

**Installation Requirements:** Results assume ± 3% nominal voltage at line side of the driver and structures located within 3 feet (1m) of design locations.

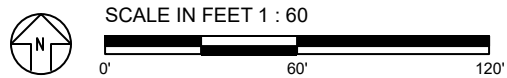

Pole location(s) ⊕ dimensions are relative to 0,0 reference point(s) ⊗



We Make It Happen.

# Rockwall ISD 9th Grade Center North

Rockwall, TX

EQUIPMENT LIST FOR AREAS SHOWN								
Pole				Luminaires				
QTY	LOCATION	SIZE	GRADE ELEVATION	MOUNTING HEIGHT	LUMINAIRE TYPE	QTY / POLE	THIS GRID	OTHER GRIDS
4	F1-F4	80'	0'	15.52'	TLC-BT-575	2	2	0
				80'	TLC-LED-1500	7	7	0
4	TOTALS					36	36	0

GRID SUMMARY	
Name:	Track
Size:	Irregular
Spacing:	30.0' x 30.0'
Height:	3.0' above grade

ILLUMINATION SUMMARY	
MAINTAINED HORIZONTAL FOOTCANDLES	
	Entire Grid
Scan Average:	18.66
Maximum:	38
Minimum:	3
Avg / Min:	5.56
Max / Min:	11.34
UG (adjacent pts):	0.00
CU:	0.16
No. of Points:	48
LUMINAIRE INFORMATION	
Applied Circuits:	A
No. of Luminaires:	36
Total Load:	44.64 kW

**Guaranteed Performance:** The ILLUMINATION described above is guaranteed per your Musco Warranty document and includes a 0.95 dirt depreciation factor.

**Field Measurements:** Individual field measurements may vary from computer-calculated predictions and should be taken in accordance with IESNA RP-6-15.

**Electrical System Requirements:** Refer to Amperage Draw Chart and/or the "Musco Control System Summary" for electrical sizing.

**Installation Requirements:** Results assume ± 3% nominal voltage at line side of the driver and structures located within 3 feet (1m) of design locations.

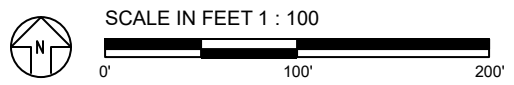
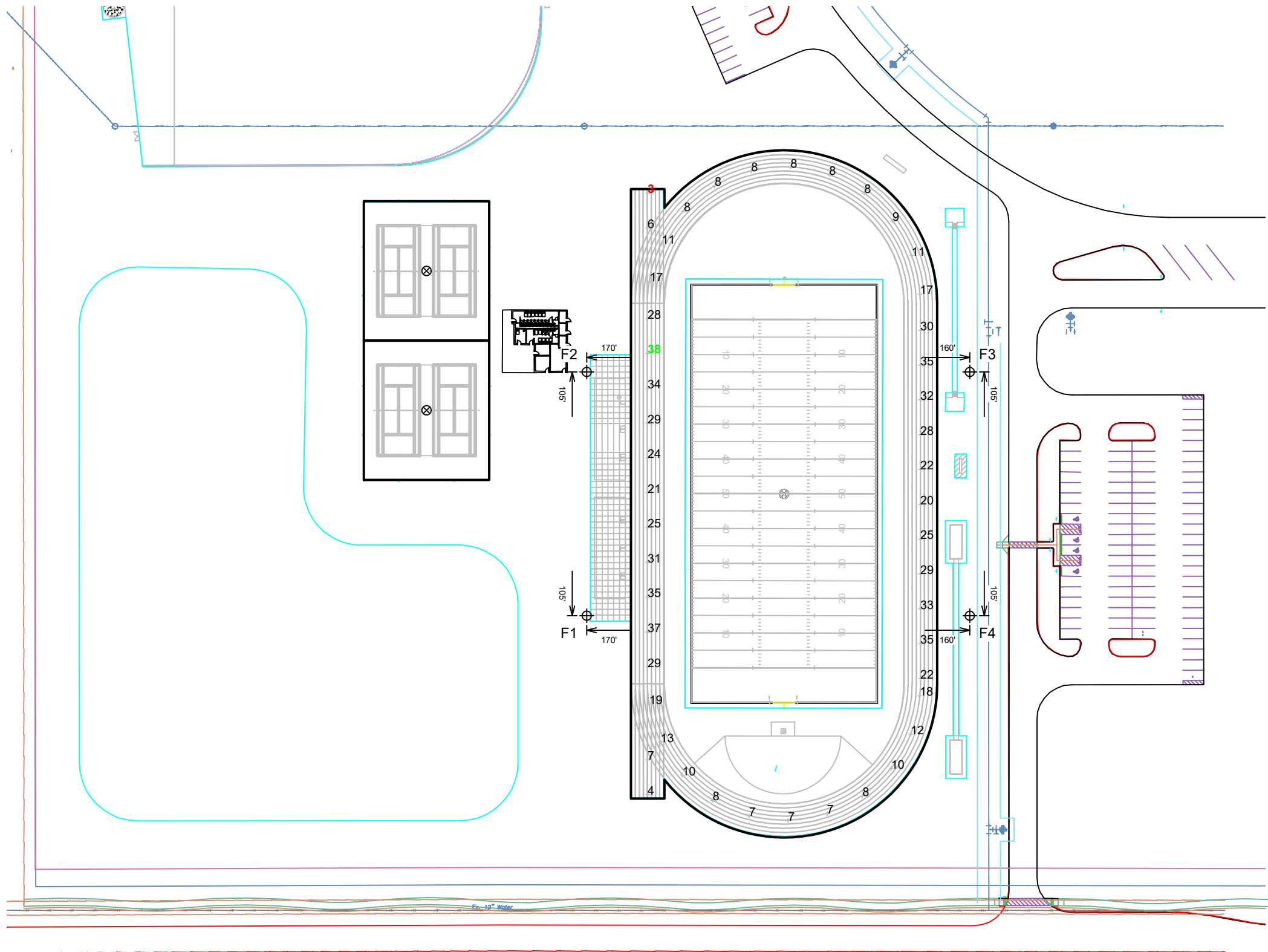

ENGINEERED DESIGN By: Ryan A. Marsh, LC · File #221256A · 28-Jul-22

Pole location(s) ⊕ dimensions are relative to 0,0 reference point(s) ⊗



Not to be reproduced in whole or part without the written consent of Musco Sports Lighting, LLC. ©1981, 2022 Musco Sports Lighting, LLC.

## ILLUMINATION SUMMARY

EQUIPMENT LIST FOR AREAS SHOWN								
Pole				Luminaires				
QTY	LOCATION	SIZE	GRADE ELEVATION	MOUNTING HEIGHT	LUMINAIRE TYPE	QTY / POLE	THIS GRID	OTHER GRIDS
2	T1-T2	40'	-	40'	TLC-LED-600	2	2	0
2	T3-T4	40'	-	40'	TLC-LED-600	4	2	2
4	TOTALS					12	8	4

GRID SUMMARY	
Name:	Tennis 1-2
Size:	2 Court - 12' Spacing
Spacing:	20.0' x 20.0'
Height:	3.0' above grade

ILLUMINATION SUMMARY	
MAINTAINED HORIZONTAL FOOTCANDLES	
Entire Grid	
Guaranteed Average:	30
Scan Average:	37.23
Maximum:	50
Minimum:	30
Avg / Min:	1.24
Guaranteed Max / Min:	2.5
Max / Min:	1.66
UG (adjacent pts):	0.00
CU:	0.88
No. of Points:	30

LUMINAIRE INFORMATION	
Applied Circuits:	B
No. of Luminaires:	8
Total Load:	4.64 kW

**Guaranteed Performance:** The ILLUMINATION described above is guaranteed per your Musco Warranty document and includes a 0.95 dirt depreciation factor.

**Field Measurements:** Individual field measurements may vary from computer-calculated predictions and should be taken in accordance with IESNA RP-6-15.

**Electrical System Requirements:** Refer to Amperage Draw Chart and/or the "Musco Control System Summary" for electrical sizing.

**Installation Requirements:** Results assume ± 3% nominal voltage at line side of the driver and structures located within 3 feet (1m) of design locations.

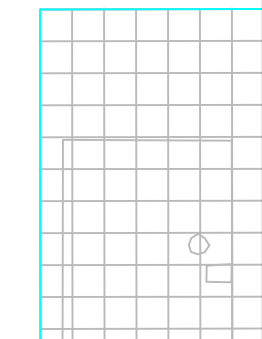
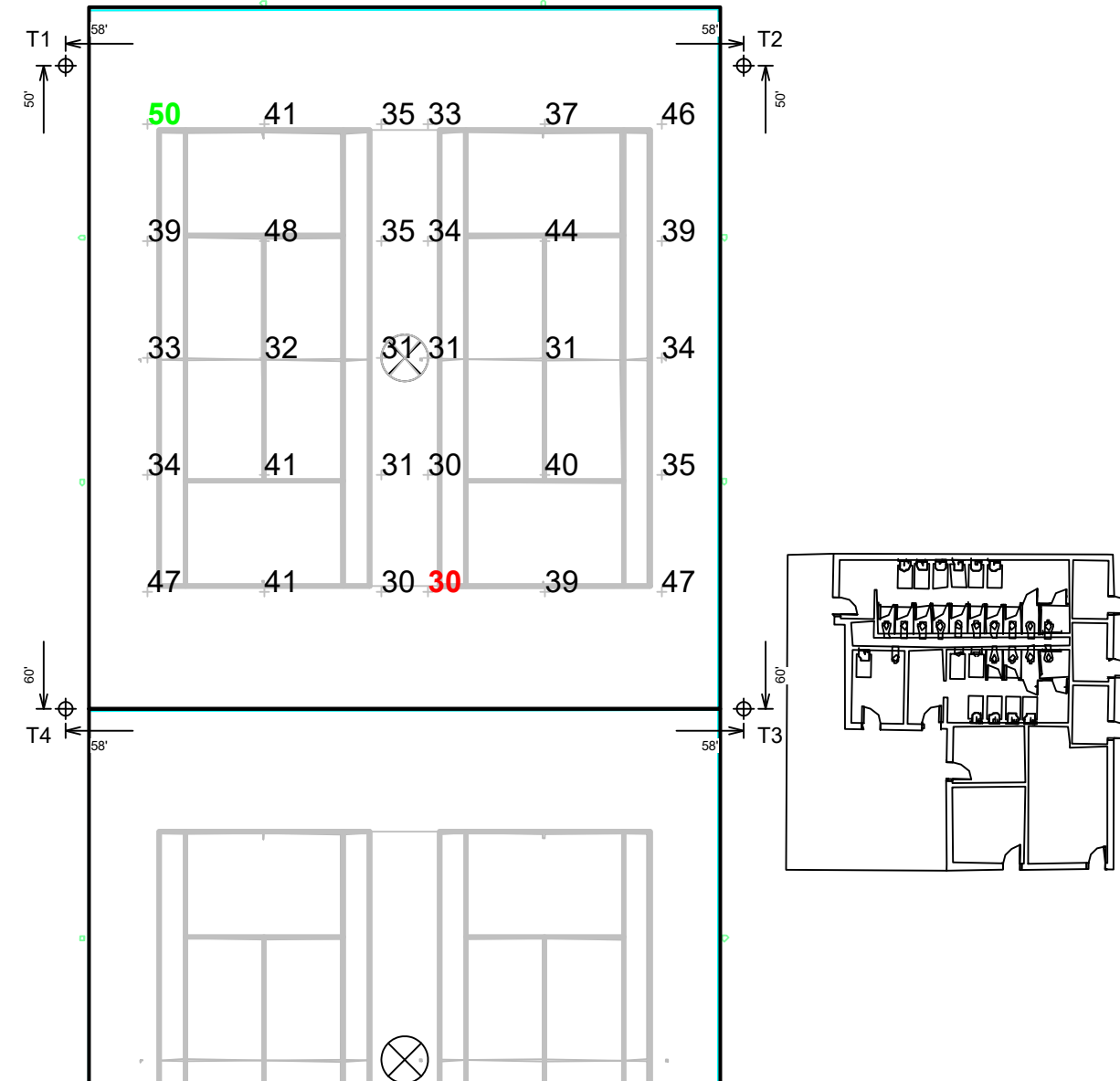

Pole location(s) Ⓢ dimensions are relative to 0,0 reference point(s) ⊗

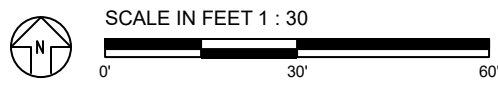

EQUIPMENT LIST FOR AREAS SHOWN									
Pole			Luminaires						
QTY	LOCATION	SIZE	GRADE ELEVATION	MOUNTING HEIGHT	LUMINAIRE TYPE	QTY / POLE	THIS GRID	OTHER GRIDS	
2	T3-T4	40'	0'	40'	TLC-LED-600	4	2	2	
2	T5-T6	40'	-	40'	TLC-LED-600	2	2	0	
4	TOTALS						12	8	4

GRID SUMMARY	
Name:	Tennis 3-4
Size:	2 Court - 12' Spacing
Spacing:	20.0' x 20.0'
Height:	3.0' above grade

ILLUMINATION SUMMARY	
MAINTAINED HORIZONTAL FOOTCANDLES	
Entire Grid	
Guaranteed Average:	30
Scan Average:	37.13
Maximum:	49
Minimum:	30
Avg / Min:	1.23
Guaranteed Max / Min:	2.5
Max / Min:	1.64
UG (adjacent pts):	0.00
CU:	0.88
No. of Points:	30
LUMINAIRE INFORMATION	
Applied Circuits:	C
No. of Luminaires:	8
Total Load:	4.64 kW

**Guaranteed Performance:** The ILLUMINATION described above is guaranteed per your Musco Warranty document and includes a 0.95 dirt depreciation factor.

**Field Measurements:** Individual field measurements may vary from computer-calculated predictions and should be taken in accordance with IESNA RP-6-15.

**Electrical System Requirements:** Refer to Amperage Draw Chart and/or the "Musco Control System Summary" for electrical sizing.

**Installation Requirements:** Results assume ± 3% nominal voltage at line side of the driver and structures located within 3 feet (1m) of design locations.

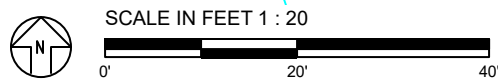
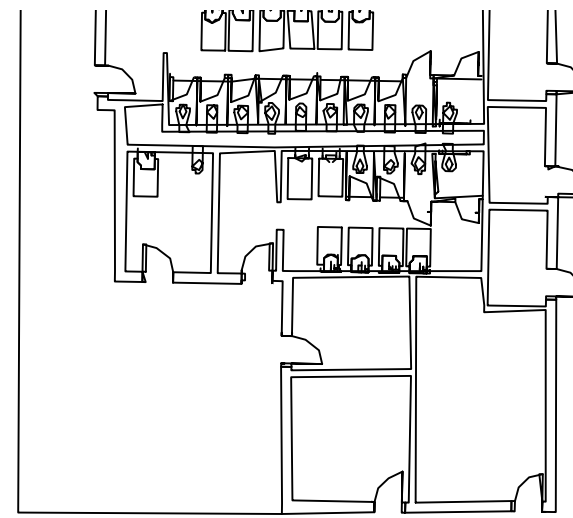
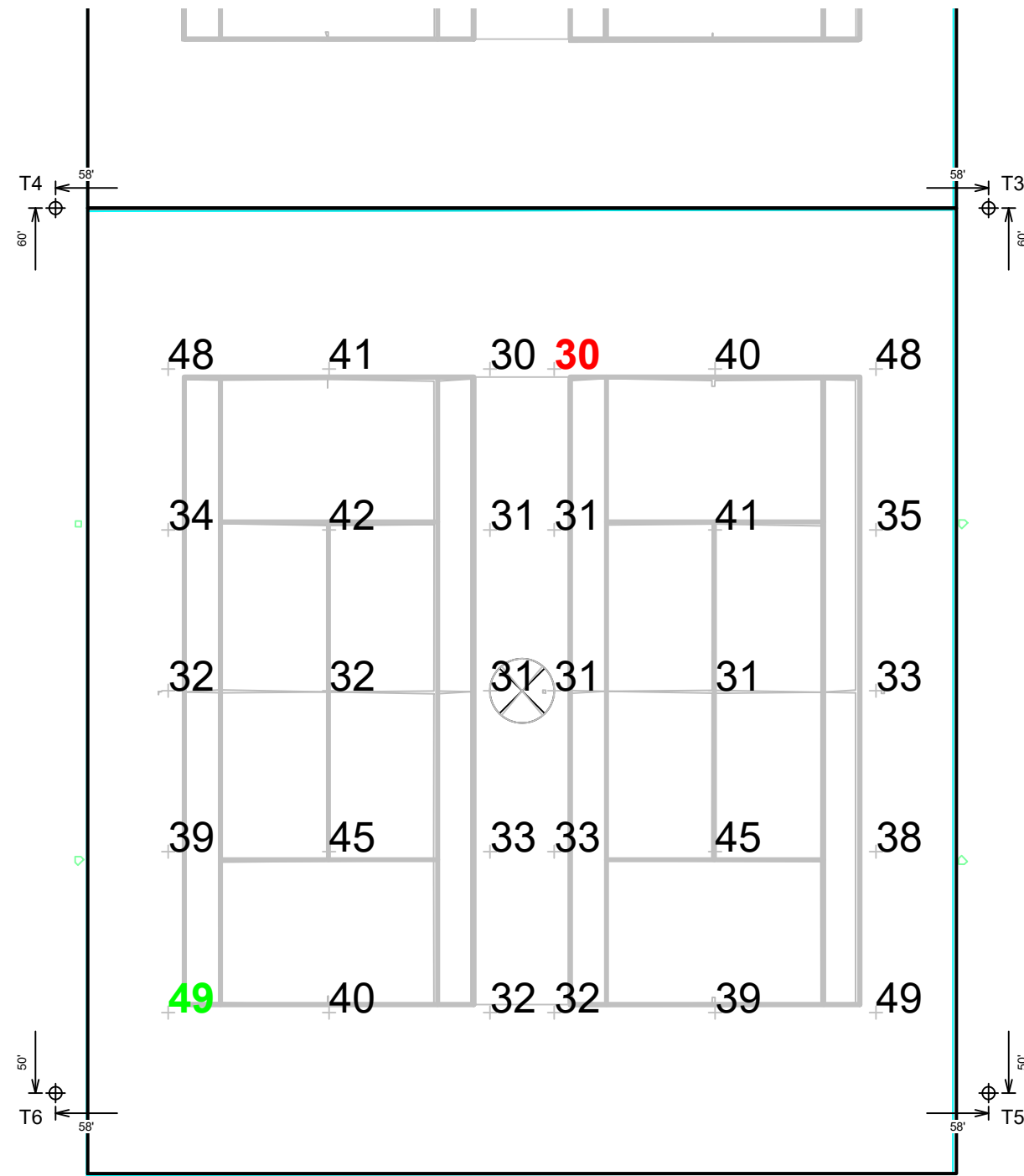

Pole location(s) Ⓢ dimensions are relative to 0,0 reference point(s) ⊗



We Make It Happen.

# Rockwall ISD 9th Grade Center North

Rockwall, TX

EQUIPMENT LIST FOR AREAS SHOWN								
Pole			Luminaires					
QTY	LOCATION	SIZE	GRADE ELEVATION	MOUNTING HEIGHT	LUMINAIRE TYPE	QTY / POLE	THIS GRID	OTHER GRIDS
2	A1-A2	70'	-	15.5'	TLC-BT-575	1	1	0
				70'	TLC-LED-1500	4	4	0
2	B1-B2	80'	-	15.5'	TLC-BT-575	1	1	0
				80'	TLC-LED-1500	6	6	0
2	C1-C2	70'	-	15.5'	TLC-BT-575	1	1	0
				70'	TLC-LED-1200	3	3	0
2	D1-D2	70'	-	15.5'	TLC-BT-575	1	1	0
				70'	TLC-LED-1200	4	4	0
8	TOTALS					42	42	0

GRID SUMMARY		
Name:	Baseball	
Size:	Irregular 315' / 390' / 315'	
Spacing:	30.0' x 30.0'	
Height:	3.0' above grade	

ILLUMINATION SUMMARY		
MAINTAINED HORIZONTAL FOOTCANDLES		
	Infield	Outfield
Guaranteed Average:	50	30
Scan Average:	52.69	33.40
Maximum:	69	45
Minimum:	39	26
Avg / Min:	1.34	1.30
Guaranteed Max / Min:	2	2.5
Max / Min:	1.75	1.75
UG (adjacent pts):	1.21	1.34
CU:	0.73	
No. of Points:	25	93

LUMINAIRE INFORMATION	
Applied Circuits:	D
No. of Luminaires:	42
Total Load:	49.58 kW

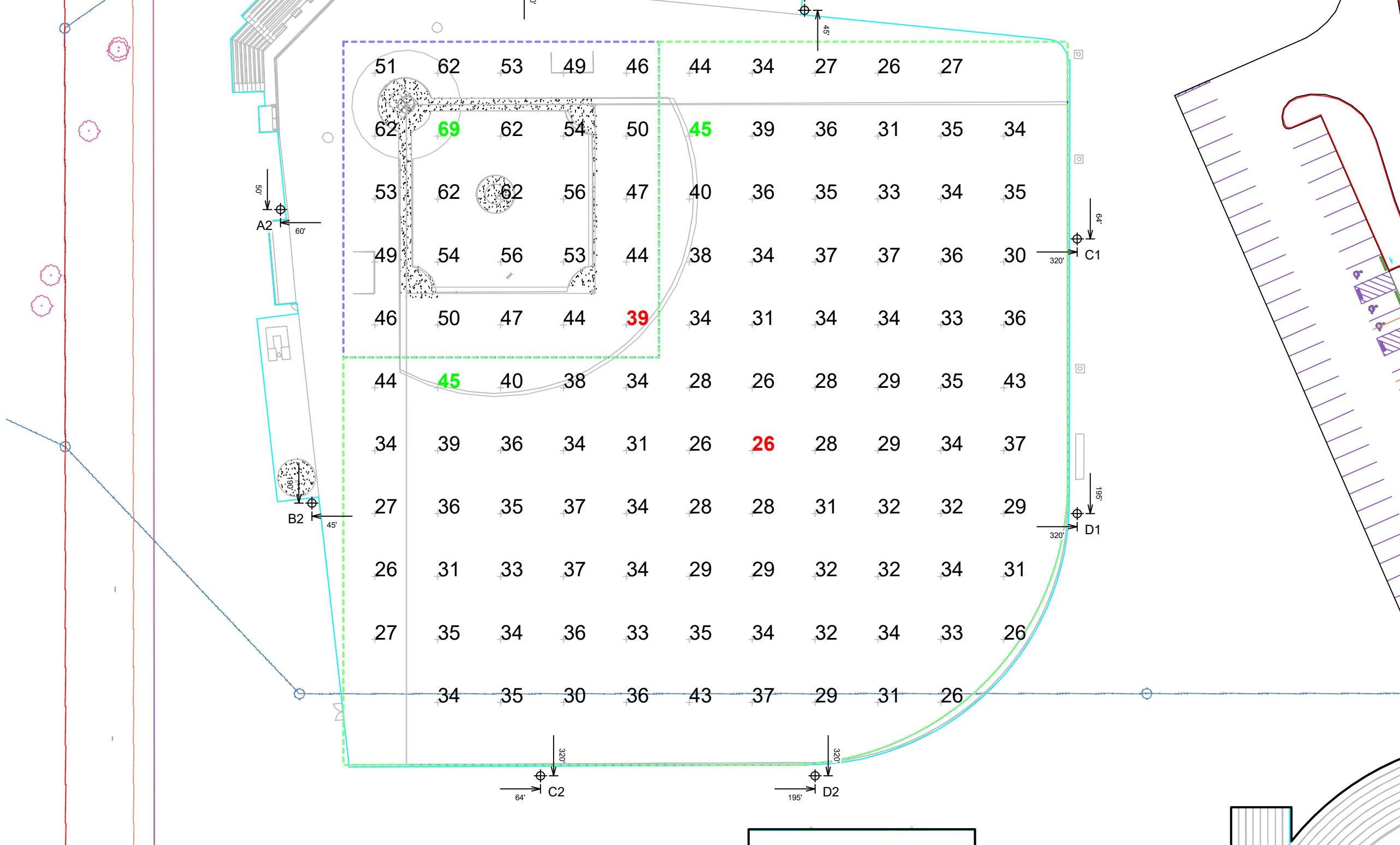

**Guaranteed Performance:** The ILLUMINATION described above is guaranteed per your Musco Warranty document and includes a 0.95 dirt depreciation factor.

**Field Measurements:** Individual field measurements may vary from computer-calculated predictions and should be taken in accordance with IESNA RP-6-15.

**Electrical System Requirements:** Refer to Amperage Draw Chart and/or the "Musco Control System Summary" for electrical sizing.

**Installation Requirements:** Results assume ± 3% nominal voltage at line side of the driver and structures located within 3 feet (1m) of design locations.

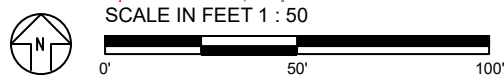

ENGINEERED DESIGN By: Ryan A. Marsh, LC · File #221256A · 28-Jul-22

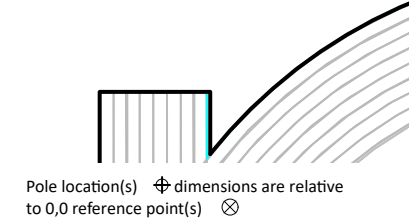

Not to be reproduced in whole or part without the written consent of Musco Sports Lighting, LLC. ©1981, 2022 Musco Sports Lighting, LLC.

## ILLUMINATION SUMMARY



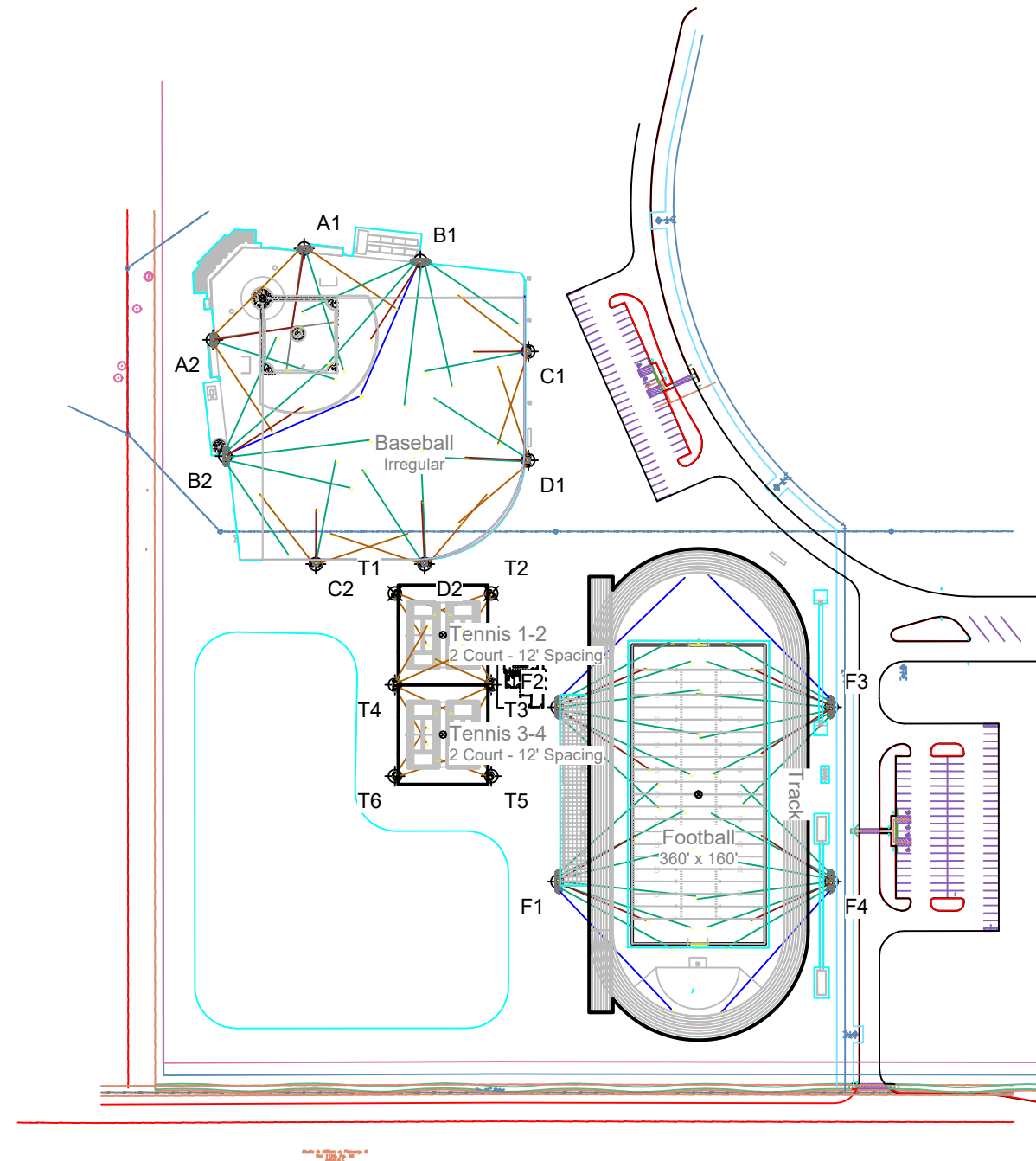

**EQUIPMENT LAYOUT**

**INCLUDES:**

- Baseball
- Football
- Tennis 1-2
- Tennis 3-4
- Track

**Electrical System Requirements:** Refer to Amperage Draw Chart and/or the "Musco Control System Summary" for electrical sizing.

**Installation Requirements:** Results assume ± 3% nominal voltage at line side of the driver and structures located within 3 feet (1m) of design locations.

**EQUIPMENT LIST FOR AREAS SHOWN**

QTY	Pole			Luminaires		QTY / POLE
	LOCATION	SIZE	GRADE ELEVATION	MOUNTING HEIGHT	LUMINAIRE TYPE	
2	A1-A2	70'	-	15.5' 70'	TLC-BT-575 TLC-LED-1500	1 4
2	B1-B2	80'	-	15.5' 80'	TLC-BT-575 TLC-LED-1500	1 6
2	C1-C2	70'	-	15.5' 70'	TLC-BT-575 TLC-LED-1200	1 3
2	D1-D2	70'	-	15.5' 70'	TLC-BT-575 TLC-LED-1200	1 4
4	F1-F4	80'	-	15.5' 80'	TLC-BT-575 TLC-LED-1500	2 7
4	T1-T2 T5-T6	40'	-	40'	TLC-LED-600	2
2	T3-T4	40'	-	40'	TLC-LED-600	4
18	TOTALS					94

**SINGLE LUMINAIRE AMPERAGE DRAW CHART**

Ballast Specifications (.90 min power factor)	Line Amperage Per Luminaire (max draw)					
	208 (60)	220 (60)	240 (60)	277 (60)	347 (60)	480 (60)
Single Phase Voltage						
TLC-LED-1500	8.5	8.1	7.4	6.4	5.1	4.7
TLC-LED-1200	7.0	6.6	6.1	5.2	4.2	4.0
TLC-BT-575	3.4	3.2	2.9	2.5	2.0	1.8
TLC-LED-600	3.4	3.2	3.0	2.6	2.0	1.5

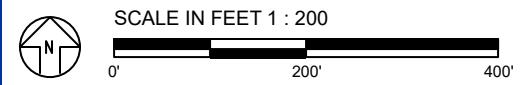

Pole location(s) Ⓧ dimensions are relative to 0,0 reference point(s) ⊗



# Rockwall ISD 9th Grade Center North

Rockwall, TX

## Lighting System

Pole / Fixture Summary						
Pole ID	Pole Height	Mtg Height	Fixture Qty	Luminaire Type	Load	Circuit
A1-A2	70'	70'	4	TLC-LED-1500	5.72 kW	D
B1-B2	80'	16'	1	TLC-BT-575	0.58 kW	D
		80'	6	TLC-LED-1500	8.58 kW	D
C1-C2	70'	70'	3	TLC-LED-1200	3.51 kW	D
		16'	1	TLC-BT-575	0.58 kW	D
D1-D2	70'	70'	4	TLC-LED-1200	4.68 kW	D
		16'	1	TLC-BT-575	0.58 kW	D
F1-F4	80'	80'	7	TLC-LED-1500	10.01 kW	A
		16'	2	TLC-BT-575	1.15 kW	A
T1-T2	40'	40'	2	TLC-LED-600	1.16 kW	B
T3	40'	40'	2	TLC-LED-600	1.16 kW	B
		40'	2	TLC-LED-600	1.16 kW	C
T4	40'	40'	2	TLC-LED-600	1.16 kW	C
		40'	2	TLC-LED-600	1.16 kW	B
T5-T6	40'	40'	2	TLC-LED-600	1.16 kW	C
<b>18</b>			<b>94</b>		<b>103.50 kW</b>	

Circuit Summary			
Circuit	Description	Load	Fixture Qty
A	Football	44.64 kW	36
B	Tennis 1-2	4.64 kW	8
C	Tennis 3-4	4.64 kW	8
D	Baseball	49.58 kW	42

Fixture Type Summary							
Type	Source	Wattage	Lumens	L90	L80	L70	Quantity
TLC-LED-1500	LED 5700K - 75 CRI	1430W	160,000	>120,000	>120,000	>120,000	48
TLC-LED-1200	LED 5700K - 75 CRI	1170W	136,000	>120,000	>120,000	>120,000	14
TLC-BT-575	LED 5700K - 75 CRI	575W	52,000	>120,000	>120,000	>120,000	16
TLC-LED-600	LED 5700K - 75 CRI	580W	65,600	>120,000	>120,000	>120,000	16

## Light Level Summary

Calculation Grid Summary								
Grid Name	Calculation Metric	Illumination					Circuits	Fixture Qty
		Ave	Min	Max	Max/Min	Ave/Min		
Baseball (Infield)	Horizontal Illuminance	52.7	39	69	1.75	1.35	D	42
Baseball (Outfield)	Horizontal Illuminance	33.4	26	45	1.75	1.28	D	42
Football	Horizontal Illuminance	36	31	43	1.40	1.16	A	36
Tennis 1-2	Horizontal Illuminance	37.2	30	50	1.66	1.24	B	8
Tennis 3-4	Horizontal Illuminance	37.1	30	49	1.64	1.24	C	8
Track	Horizontal Illuminance	18.7	3	38	11.34	6.22	A	36

## From Hometown to Professional



**We Make It Happen.**

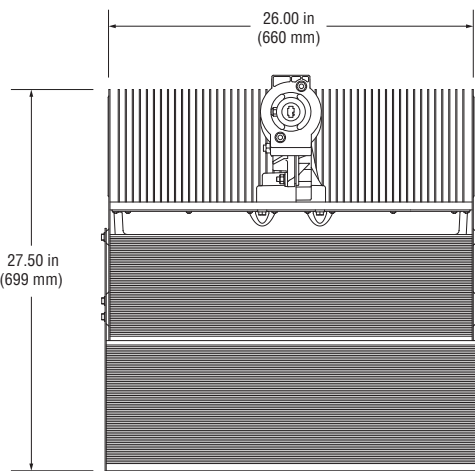
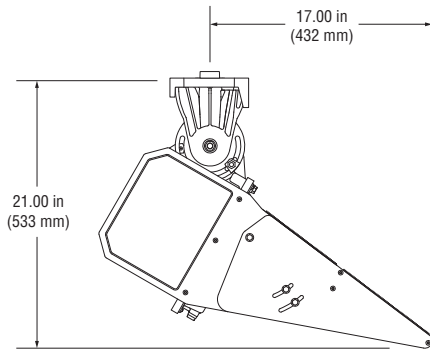
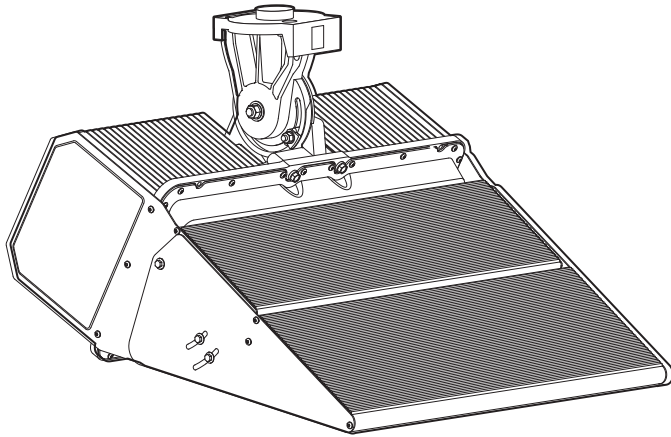

**Luminaire Data**

Weight (luminaire) ..... 80 lb (36 kg)  
 UL listing number..... E338094  
 UL listed for USA / Canada..... UL1598 CSA-C22.2 No.250.0  
 Ingress protection, luminaire, international ..... IP65  
 Ingress protection, luminaire, USA ..... IP54  
 Material and finish ..... Aluminum, powder-coat painted  
 Wind speed rating (aiming only)..... 150 mi/h (67 m/s)  
 UL ambient temperature rating, luminaire ..... 50°C (122°F)

**Photometric Characteristics**

Projected lumen maintenance per IES TM-21-11  
 L90 (10.5k) ..... >63,500 h  
 L80 (10.5k) ..... >63,500 h  
 L70 (10.5k) ..... >63,500 h  
 CIE correlated color temperature ..... 5700 K  
 Color Rendering Index (CRI), typical..... 75  
 Color Rendering Index (CRI), minimum ..... 70  
 Lumens<sup>1</sup> ..... 121,000

Footnotes:

1) Lumen values at stabilized operation in 25°C ambient temperature environment. Incorporates appropriate dirt depreciation factor for life of luminaire.

## Driver Data

### Electrical Data

Rated wattage<sup>1</sup>

Per driver..... 1,150 W

Per luminaire..... 1,150 W

Number of luminaires per driver..... 1

Starting (inrush) current..... <40 A, 256 μs

Fuse rating..... 15 A

UL, IEC ambient temperature rating,  
electrical components enclosure..... 50°C (122°F)

Ingress protection,  
electrical components enclosure..... IP54

Efficiency..... 95%

Dimming mode..... optional

Range, energy consumption..... .20 – 100%

Range, light output..... .25 – 100%

### Typical Wiring

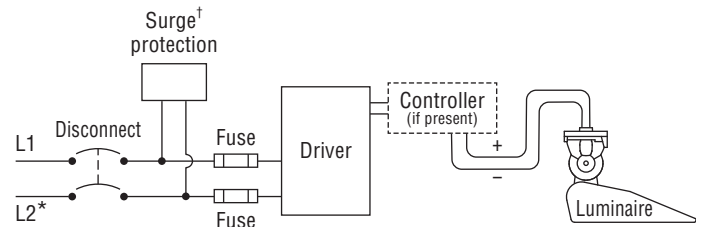

\* If L2 (com) is neutral then not switched or fused.  
† Not present if indoor installation.

	200 Vac 50/60 Hz	208 Vac 60 Hz	220 Vac 50/60 Hz	230 Vac 50 Hz	240 Vac 50/60 Hz	277 Vac 60 Hz	347 Vac 60 Hz	380 Vac 50/60 Hz	400 Vac 50 Hz	415 Vac 50 Hz	480 Vac 60 Hz
<b>Max operating current<sup>2</sup> per luminaire</b>	7.11 A	6.83 A	6.46 A	6.18 A	5.92 A	5.13 A	4.10 A	3.74 A	3.56 A	3.43 A	2.96 A

Footnotes:

- 1) Rated wattage is the power consumption, including driver efficiency losses, at stabilized operation in 25°C ambient temperature environment.
- 2) Operating current includes allowance for 0.90 minimum power factor, operating temperature, and LED light source manufacturing tolerances.

### Notes

1. Use thermal magnetic HID-rated or D-curve circuit breakers.
2. See *Musco Control System Summary* for circuit information.



## Luminaire and Driver Components – TLC-BT-575

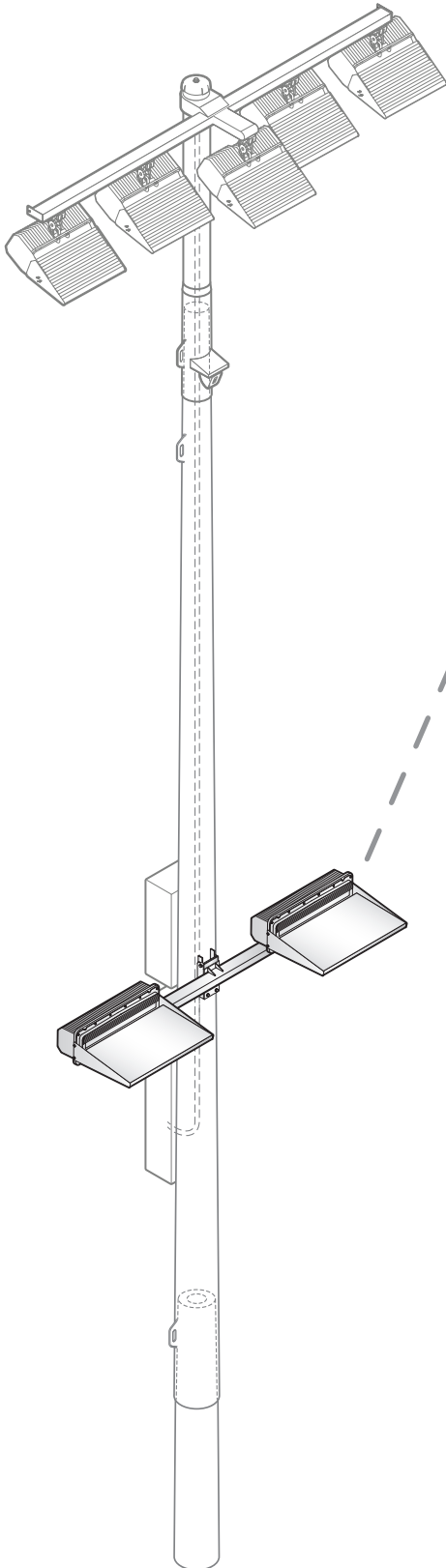

### Luminaire Data

Weight (luminaire) .....	34 lb (15 kg)
UL listing number .....	E338094
UL Listed for USA / Canada .....	UL1598 CSA-C22.2 No.250.0
Ingress protection, luminaire, international .....	IP65
Ingress protection, luminaire, USA .....	IP54
Material and finish .....	Aluminum, powder-coat painted
Wind speed rating (aiming only) .....	150 mi/h (67 m/s)

### Photometric Characteristics

Projected lumen maintenance per IES TM-21-11	
L90 (10.5k) .....	>63,500 h
L80 (10.5k) .....	>63,500 h
L70 (10.5k) .....	>63,500 h
CIE correlated color temperature .....	5700 K
Color Rendering Index (CRI), typical .....	75
Color Rendering Index (CRI), minimum .....	70
Lumens <sup>1</sup> .....	52,000

Footnotes:

1) Incorporates appropriate dirt depreciation factor for life of luminaire.

All components from foundation to poletop are designed to work together in Light-Structure System™ to ensure reliable, trouble-free operation.

## Luminaire and Driver Components – TLC-BT-575

### Driver Data

#### Electrical Data

Rated wattage<sup>1</sup>

Per driver..... 575 W

Per luminaire..... 575 W

Number of luminaires per driver..... 1

Starting (inrush) current..... <40 A, 256 µs

Fuse rating..... 15 A

UL, IEC ambient temperature rating,  
electrical components enclosure ..... 50°C (122°F)

Ingress protection,  
electrical components enclosure ..... IP54

Efficiency..... 95%

### Typical Wiring

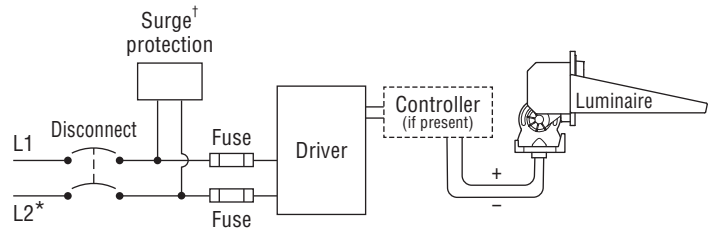

\* If L2 (com) is neutral then not switched or fused.

† Not present if indoor installation.

	200 Vac 50/60 Hz	208 Vac 60 Hz	220 Vac 50/60 Hz	230 Vac 50 Hz	240 Vac 50/60 Hz	277 Vac 60 Hz	347 Vac 60 Hz	380 Vac 50/60 Hz	400 Vac 50 Hz	415 Vac 50 Hz	480 Vac 60 Hz
<b>Max operating current<sup>2</sup> per luminaire</b>	3.30 A	3.17 A	3.00 A	2.87 A	2.75 A	2.38 A	1.90 A	1.74 A	1.65 A	1.59 A	1.38 A

Footnotes:

- 1) Rated wattage is the power consumption, including driver efficiency losses, at stabilized operation in 25°C ambient temperature environment.
- 2) Operating current includes allowance for 0.90 minimum power factor, operating temperature, and LED light source manufacturing tolerances.

#### Notes

1. Use thermal magnetic HID-rated or D-curve circuit breakers.
2. See *Musco Control System Summary* for circuit information.

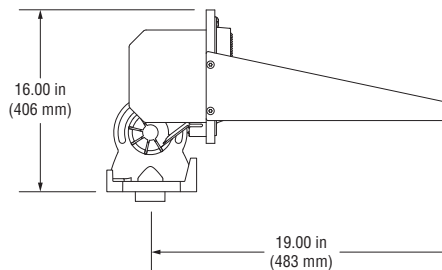
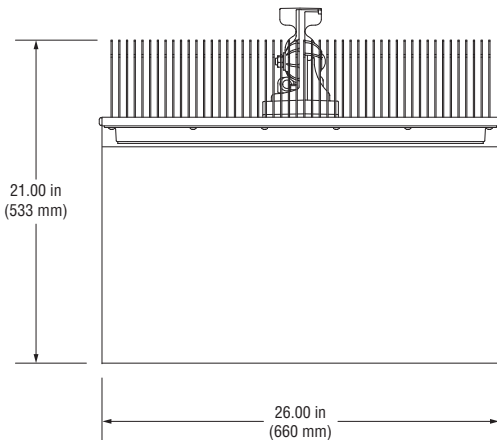

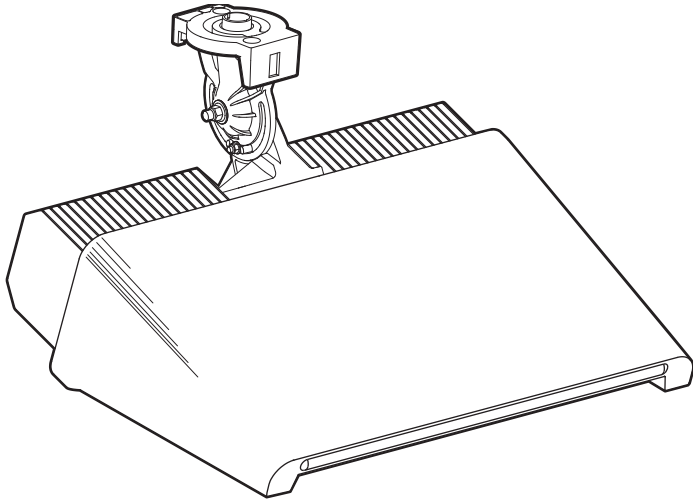

**Luminaire Data**

Weight (luminaire) ..... 40 lb (18 kg)  
 UL listing number ..... E338094  
 UL Listed for USA / Canada ..... UL1598 CSA-C22.2 No.250.0  
 Ingress protection, luminaire, international ..... IP65  
 Ingress protection, luminaire, USA ..... IP54  
 Material and finish ..... Aluminum,  
 powder-coat painted  
 Wind speed rating (aiming only) ..... 150 mi/h (67 m/s)

**Photometric Characteristics**

Projected lumen maintenance per IES TM-21-11  
 L90(10.5k) ..... >63,500 h  
 L80(10.5k) ..... >63,500 h  
 L70(10.5k) ..... >63,500 h  
 CIE correlated color temperature ..... 5700 K  
 Color Rendering Index (CRI), typical ..... 75  
 Color Rendering Index (CRI), minimum ..... 70  
 Lumens<sup>1</sup> ..... 46,500

Footnotes:

1) Incorporates appropriate dirt depreciation factor for life of luminaire.

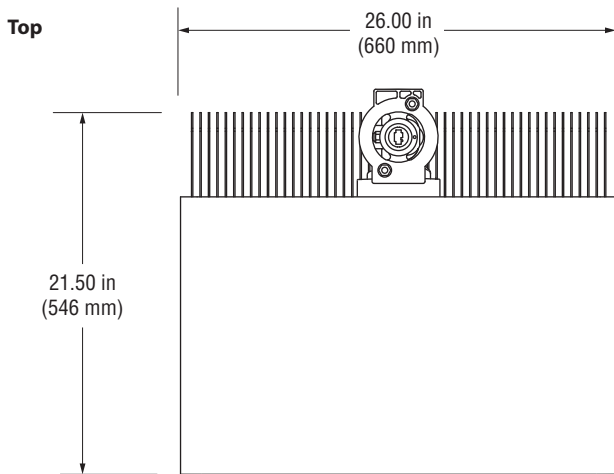
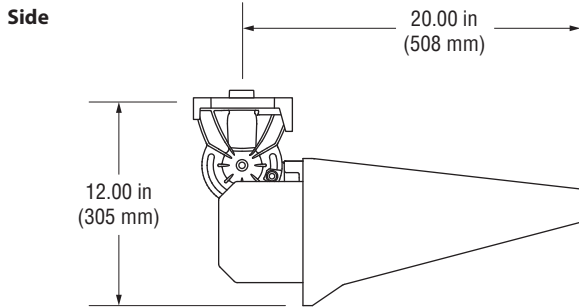



# WST LED

## Architectural Wall Sconce



Catalog Number
Notes
Type

Hit the Tab key or mouse over the page to see all interactive elements.

### A+ Capable Luminaire

This item is an A+ capable luminaire, which has been designed and tested to provide consistent color appearance and system-level interoperability.

- All configurations of this luminaire meet the Acuity Brands' specification for chromatic consistency
- This luminaire is A+ Certified when ordered with DTL® controls marked by a **shaded background**. DTL DLL equipped luminaires meet the A+ specification for luminaire to photocontrol interoperability1
- This luminaire is part of an A+ Certified solution for ROAM® or XPoint™ Wireless control networks, providing out-of-the-box control compatibility with simple commissioning, when ordered with drivers and control options marked by a **shaded background**<sup>1</sup>

To learn more about A+, visit [www.acuitybrands.com/aplus](http://www.acuitybrands.com/aplus).

See ordering tree for details.

A+ Certified Solutions for ROAM require the order of one ROAM node per luminaire. Sold Separately: [Link to Roam](#); [Link to DTL DLL](#)

## Specifications

### Luminaire

- Height:** 8-1/2"  
(21.59 cm)
- Width:** 17"  
(43.18 cm)
- Depth:** 10-3/16"  
(25.9 cm)
- Weight:** 20 lbs  
(9.1 kg)

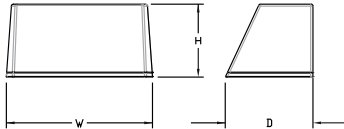

### Optional Back Box (PBBW)

- Height:** 8.49"  
(21.56 cm)
- Width:** 17.01"  
(43.21 cm)
- Depth:** 1.70"  
(4.32 cm)

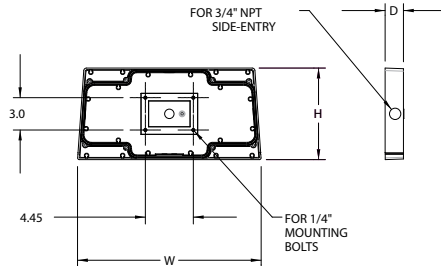

### Optional Back Box (BBW)

- Height:** 4"  
(10.2 cm)
- Width:** 5-1/2"  
(14.0 cm)
- Depth:** 1-1/2"  
(3.8 cm)

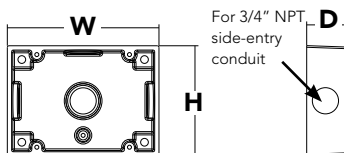



## Ordering Information

**EXAMPLE: WST LED P1 40K VF MVOLT DDBTXD**

WST LED								
Series	Performance Package	Color temperature		Distribution	Voltage		Mounting	
WST LED	P1	1,500 Lumen package	27K	2700 K	VF	Visual comfort forward throw	MVOLT <sup>1</sup> 277 <sup>2</sup>	<b>Shipped included</b> (blank) Surface mounting bracket PBBW Premium surface-mounted back box <sup>3,4</sup> <b>Shipped separately</b> BBW Surface-mounted back box <sup>3</sup>
	P2	3,000 Lumen package	30K	3000 K	VW	Visual comfort wide	120 <sup>3</sup> 347 <sup>2</sup>	
	P3	6,000 Lumen package	40K	4000 K			208 <sup>2</sup> 480 <sup>2</sup>	
			50K	5000 K			240 <sup>2</sup>	

Options				Finish (required)			
NLTAIR2 PIR	nLIGHT AIR Wireless enabled motion/ambient sensor for 8'-15' mounting heights <sup>5,6,7</sup>			E7WC	Emergency battery backup, CA Title 20 Noncompliant (cold, 7W) <sup>7,12</sup>	DDBXD	Dark bronze
NLTAIR2 PIRH	nLIGHT AIR Wireless enabled motion/ambient sensor for 15'-30' mounting heights <sup>5,6,7</sup>			E7WHR	Remote emergency battery backup, CA Title 20 Noncompliant (remote 7W) <sup>7,13</sup>	DBLXD	Black
PE	Photoelectric cell, button type <sup>8</sup>			E20WH	Emergency battery pack 18W constant power, Certified in CA Title 20 MAEDBS <sup>7</sup>	DNAXD	Natural aluminum
PER	NEMA twist-lock receptacle only (controls ordered separate) <sup>9</sup>			E20WC	Emergency battery pack -20°C 18W constant power, Certified in CA Title 20 MAEDBS <sup>7,12</sup>	DWHXD	White
PER5	Five-wire receptacle only (controls ordered separate) <sup>9</sup>			E23WHR	Remote emergency battery backup, CA Title 20 Noncompliant (remote 20W) <sup>7,12,14</sup>	DSSXD	Sandstone
PER7	Seven-wire receptacle only (controls ordered separate) <sup>9</sup>			LCE	Left side conduit entry <sup>15</sup>	DBBXTD	Textured dark bronze
PIR	Motion/Ambient Light Sensor, 8-15' mounting height <sup>5,6</sup>			RCE	Right side conduit entry <sup>15</sup>	DBLXTD	Textured black
PIR1FC3V	Motion/ambient sensor, 8-15' mounting height, ambient sensor enabled at 1fc <sup>5,6</sup>			BAA	Buy America(n) Act Compliant	DNATXD	Textured natural aluminum
PIRH	180° motion/ambient light sensor, 15-30' mounting height <sup>5,6</sup>			<b>Shipped separately</b>			
PIRH1FC3V	Motion/ambient sensor, 15-30' mounting height, ambient sensor enabled at 1fc <sup>5,6</sup>			RBPW	Retrofit back plate <sup>3</sup>	DWHGXD	Textured white
SF	Single fuse (120, 277, 347V) <sup>2</sup>			VG	Vandal guard <sup>15</sup>	DSSTXD	Textured sandstone
DF	Double fuse (208, 240, 480V) <sup>2</sup>			WG	Wire guard <sup>15</sup>		
DS	Dual switching <sup>10</sup>						
DMG	0-10V dimming extend out back of housing for external control (control ordered separate) <sup>11</sup>						
E7WH	Emergency battery backup, Non CEC compliant (7W) <sup>7</sup>						

## Accessories

Ordered and shipped separately.

WSTVCPBBW DDBXD U	Premium Surface - mounted back box
WSBBW DDBTXD U	Surface - mounted back box
RBPW DDBXD U	Retrofit back plate
DLL127F 1.5 JU	Photocell - SSL twist-lock (120-277V) <sup>17</sup>
DLL347F 1.5 CUL JU	Photocell - SSL twist-lock (347V) <sup>17</sup>
DLL480F 1.5 CUL JU	Photocell - SSL twist-lock (480V) <sup>17</sup>

## NOTES

- MVOLT driver operates on any line voltage from 120-277V (50/60 Hz).
- Single fuse (SF) requires 120V, 277V or 347V. Double fuse (DF) requires 208V, 240V or 480V.
- Also available as a separate accessory; see accessories information.
- Top conduit entry standard.
- Not available with VG or WG. See PER Table.
- Reference Motion Sensor table.
- Not available with 347/480V.
- Need to specify 120, 208, 240 or 277 voltage.
- Photocell ordered and shipped as a separate line item from Acuity Brands Controls. Shorting Cap included.
- Not available with Emergency options, PE or PER options.
- DMG option not available with standalone or networked sensors/controls.
- Battery pack rated for -20° to 40°C.
- Comes with PBBW.
- Warranty period is 3-years.
- Not available with BBW.
- Must order with fixture; not an accessory.
- Requires luminaire to be specified with PER, PER5 or PER7 option. See PER Table.

## Emergency Battery Operation

The emergency battery backup is integral to the luminaire — no external housing required! This design provides reliable emergency operation while maintaining the aesthetics of the product. All emergency backup configurations include an independent secondary driver with an integral relay to immediately detect AC power loss, meeting interpretations of [NFPA 70/NEC 2008 - 700.16](#). The emergency battery will power the luminaire for a minimum duration of 90 minutes (maximum duration of three hours) from the time supply power is lost, per [International Building Code Section 1006](#) and [NFPA 101 Life Safety Code Section 7.9](#), provided luminaires are mounted at an appropriate height and illuminate an open space with no major obstructions. The examples below show illuminance of 1 fc average and 0.1 fc minimum of the P1 power package and VF distribution product in emergency mode.

10' x 10' Gridlines  
8' and 12' Mounting Height

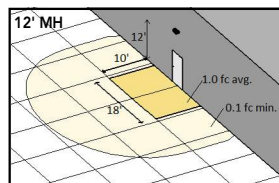
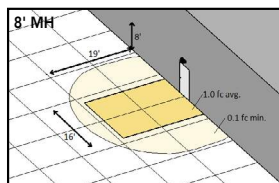

WST LED P1 27K VF MVOLT E7WH

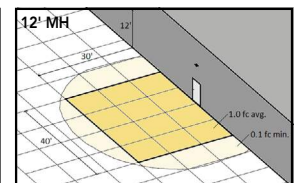
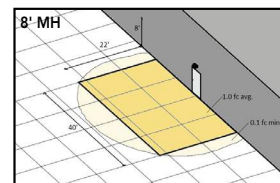

WST LED P2 40K VF MVOLT E20WH

## Performance Data

### Lumen Ambient Temperature (LAT) Multipliers

Use these factors to determine relative lumen output for average ambient temperatures from 0-40°C (32-104°F).

Ambient		Lumen Multiplier
0°C	32°F	1.03
10°C	50°F	1.02
20°C	68°F	1.01
<b>25°C</b>	<b>77°F</b>	<b>1.00</b>
30°C	86°F	0.99
40°C	104°F	0.98

### Electrical Load

Performance package	System Watts	Current (A)					
		120	208	240	277	347	480
P1	11	0.1	0.06	0.05	0.04	---	---
	14	---	---	---	---	0.04	0.03
P1 DS	14	0.12	0.07	0.06	0.06	---	---
	P2	25	0.21	0.13	0.11	0.1	---
30		---	---	---	---	0.09	0.06
P2 DS	25	0.21	0.13	0.11	0.1	---	---
	P3	50	0.42	0.24	0.21	0.19	---
56		---	---	---	---	0.16	0.12
P3 DS	52	0.43	0.26	0.23	0.21	---	---

### Projected LED Lumen Maintenance

Values calculated according to IESNA TM-21-11 methodology and valid up to 40°C.

Operating Hours	0	25,000	50,000	100,000
Lumen Maintenance Factor	1.0	>0.95	>0.92	>0.87

### Motion Sensor Default Settings

Option	Dimmed State	High Level (when triggered)	Photocell Operation	Ramp-up Time	Dwell Time	Ramp-down Time
*PIR or PIRH	3V (37%) Output	10V (100%) Output	Enabled @ 5FC	3 sec	5 min	5 min
PIR1FC3V or PIRH1FC3V	3V (37%) Output	10V (100%) Output	Enabled @ 1FC	3 sec	5 min	5 min

\*for use with site wide Dusk to Dawn control

### PER Table

Control	PER (3 wire)	PER5 (5 wire)		PER7 (7 wire)		
			Wire 4/Wire5		Wire 4/Wire5	Wire 6/Wire7
Photocontrol Only (On/Off)	✓	⚠	Wired to dimming leads on driver	⚠	Wired to dimming leads on driver	Wires Capped inside fixture
ROAM	⊘	✓	Wired to dimming leads on driver	⚠	Wired to dimming leads on driver	Wires Capped inside fixture
ROAM with Motion	⊘	⚠	Wired to dimming leads on driver	⚠	Wired to dimming leads on driver	Wires Capped inside fixture
Futureproof*	⊘	⚠	Wired to dimming leads on driver	✓	Wired to dimming leads on driver	Wires Capped inside fixture
Futureproof* with Motion	⊘	⚠	Wired to dimming leads on driver	✓	Wired to dimming leads on driver	Wires Capped inside fixture

✓ Recommended

⊘ Will not work

⚠ Alternate

\*Futureproof means: Ability to change controls in the future.

### Lumen Output

Lumen values are from photometric tests performed in accordance with IESNA LM-79-08. Data is considered to be representative of the configurations shown, within the tolerances allowed by Lighting Facts.

Performance Package	System Watts (MVOLT*)	Dist. Type	27K (2700K, 70 CRI)					30K (3000K, 70 CRI)					40K (4000K, 70 CRI)					50K (5000K, 70 CRI)				
			Lumens	B	U	G	LPW	Lumens	B	U	G	LPW	Lumens	B	U	G	LPW	Lumens	B	U	G	LPW
P1	12W	VF	1,494	0	0	0	125	1,529	0	0	0	127	1,639	0	0	0	137	1,639	0	0	0	137
		VW	1,513	0	0	0	126	1,548	0	0	0	129	1,659	0	0	0	138	1,660	0	0	0	138
P2	25W	VF	3,163	1	0	1	127	3,237	1	0	1	129	3,469	1	0	1	139	3,468	1	0	1	139
		VW	3,201	1	0	0	128	3,276	1	0	0	131	3,512	1	0	0	140	3,512	1	0	0	140
P3	50W	VF	6,025	1	0	1	121	6,165	1	0	1	123	6,609	1	0	1	132	6,607	1	0	1	132
		VW	6,098	1	0	1	122	6,240	1	0	1	125	6,689	1	0	1	134	6,691	1	0	1	134



Isofootcandle plots for the WST LED P3 40K VF and VW. Distances are in units of mounting height (10').

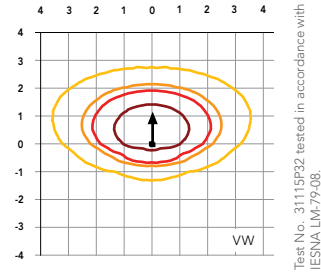
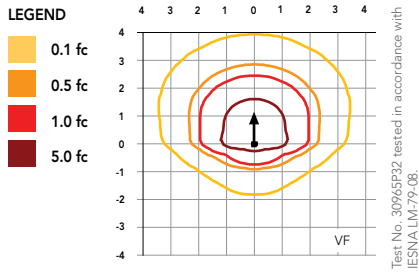

Distribution overlay comparison to 175W metal halide.

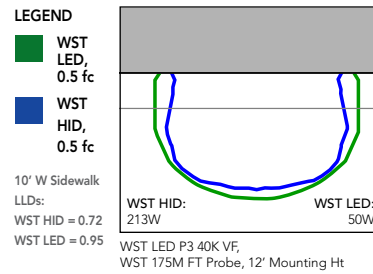

## FEATURES & SPECIFICATIONS

### INTENDED USE

The classic architectural shape of the WST LED was designed for applications such as hospitals, schools, malls, restaurants, and commercial buildings. The long life LEDs and driver make this luminaire nearly maintenance-free.

### CONSTRUCTION

The single-piece die-cast aluminum housing integrates secondary heat sinks to optimize thermal transfer from the internal light engine heat sinks and promote long life. The driver is mounted in direct contact with the casting for a low operating temperature and long life. The die-cast door frame is fully gasketed with a one-piece solid silicone gasket to keep out moisture and dust, providing an IP65 rating for the luminaire.

### FINISH

Exterior parts are protected by a zinc-infused Super Durable TGIC thermoset powder coat finish that provides superior resistance to corrosion and weathering. A tightly controlled multi-stage process ensures a minimum 3 mils thickness for a finish that can withstand extreme climate changes without cracking or peeling. Standard Super Durable colors include dark bronze, black, natural aluminum, sandstone and white. Available in textured and non-textured finishes.

### OPTICS

Well crafted reflector optics allow the light engine to be recessed within the luminaire, providing visual comfort, superior distribution, uniformity, and spacing in wall-mount applications. The WST LED has zero uplight and qualifies as a Nighttime Friendly™ product, meaning it is consistent with the LEED® and Green Globes™ criteria for eliminating wasteful uplight.

### ELECTRICAL

Light engine(s) consist of 98 high-efficacy LEDs mounted to a metal core circuit board and integral aluminum heat sinks to maximize heat dissipation and promote long life (100,000 hrs at 40°C, L87). Class 2 electronic driver has a power factor >90%, THD <20%. Easily-serviceable surge protection device meets a minimum Category B (per ANSI/IEEE C62.41.2).

### INSTALLATION

A universal mounting plate with integral mounting support arms allows the fixture to hinge down for easy access while making wiring connections.

### LISTINGS

CSA certified to U.S. and Canadian standards. Luminaire is IP65 rated. PIR and back box options are rated for wet location. Rated for -30°C to 40°C ambient.

DesignLights Consortium® (DLC) Premium qualified product. Not all versions of this product may be DLC Premium qualified. Please check the DLC Qualified Products List at [www.designlights.org/QPL](http://www.designlights.org/QPL) to confirm which versions are qualified.

### BUY AMERICAN

Product with the BAA option is assembled in the USA and meets the Buy America(n) government procurement requirements under FAR, DFARS and DOT. Please refer to [www.acuitybrands.com/buy-american](http://www.acuitybrands.com/buy-american) for additional information.

### WARRANTY

5-year limited warranty. This is the only warranty provided and no other statements in this specification sheet create any warranty of any kind. All other express and implied warranties are disclaimed. Complete warranty terms located at: [www.acuitybrands.com/support/warranty/terms-and-conditions](http://www.acuitybrands.com/support/warranty/terms-and-conditions)

**Note:** Actual performance may differ as a result of end-user environment and application. All values are design or typical values, measured under laboratory conditions at 25 °C. Specifications subject to change without notice.

