



PLANNING AND ZONING CASE CHECKLIST

City of Rockwall
Planning and Zoning Department
385 S. Goliad Street
Rockwall, Texas 75087

P&Z CASE # Z2020-034 P&Z DATE 09/14/20 CC DATE 09/21/20 APPROVED/DENIED _____
ARCHITECTURAL REVIEW BOARD DATE _____ HPAB DATE _____ PARK BOARD DATE _____

ZONING APPLICATION	
<input checked="" type="checkbox"/>	SPECIFIC USE PERMIT
<input type="checkbox"/>	ZONING CHANGE
<input type="checkbox"/>	PD CONCEPT PLAN
<input type="checkbox"/>	PD DEVELOPMENT PLAN

SITE PLAN APPLICATION	
<input type="checkbox"/>	SITE PLAN
<input type="checkbox"/>	LANDSCAPE PLAN
<input type="checkbox"/>	TREESCAPE PLAN
<input type="checkbox"/>	PHOTOMETRIC PLAN
<input type="checkbox"/>	BUILDING ELEVATIONS
<input type="checkbox"/>	MATERIAL SAMPLES
<input type="checkbox"/>	COLOR RENDERING

PLATTING APPLICATION	
<input type="checkbox"/>	MASTER PLAT
<input type="checkbox"/>	PRELIMINARY PLAT
<input type="checkbox"/>	FINAL PLAT
<input type="checkbox"/>	REPLAT
<input type="checkbox"/>	ADMINISTRATIVE/MINOR PLAT
<input type="checkbox"/>	VACATION PLAT
<input type="checkbox"/>	LANDSCAPE PLAN
<input type="checkbox"/>	TREESCAPE PLAN

<input type="checkbox"/>	COPY OF ORDINANCE (ORD.# _____)
<input checked="" type="checkbox"/>	APPLICATIONS
<input checked="" type="checkbox"/>	RECEIPT
<input checked="" type="checkbox"/>	LOCATION MAP
<input checked="" type="checkbox"/>	HOA MAP
<input checked="" type="checkbox"/>	PON MAP
<input type="checkbox"/>	FLU MAP
<input type="checkbox"/>	NEWSPAPER PUBLIC NOTICE
<input type="checkbox"/>	500-FT. BUFFER PUBLIC NOTICE
<input type="checkbox"/>	PROJECT REVIEW
<input type="checkbox"/>	STAFF REPORT
<input type="checkbox"/>	CORRESPONDENCE
<input type="checkbox"/>	COPY-ALL PLANS REQUIRED
<input type="checkbox"/>	COPY-MARK-UPS
<input type="checkbox"/>	CITY COUNCIL MINUTES-LASERFICHE
<input type="checkbox"/>	MINUTES-LASERFICHE
<input type="checkbox"/>	PLAT FILED DATE _____
<input type="checkbox"/>	CABINET # _____
<input type="checkbox"/>	SLIDE # _____
NOTES: _____	

ZONING MAP UPDATED _____	



DEVELOPMENT APPLICATION

City of Rockwall
Planning and Zoning Department
385 S. Goliad Street
Rockwall, Texas 75087

STAFF USE ONLY

PLANNING & ZONING CASE NO. 22020-034

NOTE: THE APPLICATION IS NOT CONSIDERED ACCEPTED BY THE CITY UNTIL THE PLANNING DIRECTOR AND CITY ENGINEER HAVE SIGNED BELOW.

DIRECTOR OF PLANNING:

CITY ENGINEER:

Please check the appropriate box below to indicate the type of development request [SELECT ONLY ONE BOX]:

Platting Application Fees:

- Master Plat (\$100.00 + \$15.00 Acre) ¹
- Preliminary Plat (\$200.00 + \$15.00 Acre) ¹
- Final Plat (\$300.00 + \$20.00 Acre) ¹
- Replat (\$300.00 + \$20.00 Acre) ¹
- Amending or Minor Plat (\$150.00)
- Plat Reinstatement Request (\$100.00)

Site Plan Application Fees:

- Site Plan (\$250.00 + \$20.00 Acre) ¹
- Amended Site Plan/Elevations/Landscaping Plan (\$100.00)

Zoning Application Fees:

- Zoning Change (\$200.00 + \$15.00 Acre) ¹
- Specific Use Permit (\$200.00 + \$15.00 Acre) ¹
- PD Development Plans (\$200.00 + \$15.00 Acre) ¹

Other Application Fees:

- Tree Removal (\$75.00)
- Variance Request (\$100.00)

Notes:

¹: In determining the fee, please use the exact acreage when multiplying by the per acre amount. For requests on less than one acre, round up to one (1) acre.

PROPERTY INFORMATION [PLEASE PRINT]

Address 118 Mischeif Lane

Subdivision Chandler's Landing Phase 20

Lot 12

Block A

General Location

ZONING, SITE PLAN AND PLATTING INFORMATION [PLEASE PRINT]

Current Zoning

Current Use Vacant lot

Proposed Zoning

Proposed Use Private SFR

Acreage

Lots [Current]

Lots [Proposed]

SITE PLANS AND PLATS: By checking this box you acknowledge that due to the passage of HB3167 the City no longer has flexibility with regard to its approval process, and failure to address any of staff's comments by the date provided on the Development Calendar will result in the denial of your case.

OWNER/APPLICANT/AGENT INFORMATION [PLEASE PRINT/CHECK THE PRIMARY CONTACT/ORIGINAL SIGNATURES ARE REQUIRED]

Owner Major Rush

Applicant

Contact Person Carolyn Sternes - Tilson Homes

Contact Person

Address 411 Durham Dr.

Address

City, State & Zip Houston, TX. 77007

City, State & Zip

Phone 713-293-3104

Phone

E-Mail sternes@tilsonhome.com

E-Mail

NOTARY VERIFICATION [REQUIRED]

Before me, the undersigned authority, on this day personally appeared Major Rush [Owner] the undersigned, who stated the information on this application to be true and certified the following:

"I hereby certify that I am the owner for the purpose of this application; all information submitted herein is true and correct; and the application fee of \$ _____, to cover the cost of this application, has been paid to the City of Rockwall on this the 13 day of AUG, 2020. By signing this application, I agree that the City of Rockwall (i.e. "City") is authorized and permitted to provide information contained within this application to the public. The City is also authorized and permitted to reproduce any copyrighted information submitted in conjunction with this application, if such reproduction is associated or in response to a request for public information."

Given under my hand and seal of office on this the 13 day of AUG, 2020.

Owner's Signature

Major Rush

Notary Public in and for the State of Texas

Jim Williams

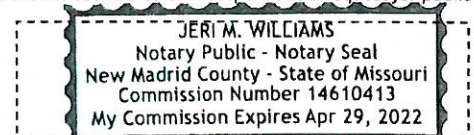

My Commission Expires 04.29.2022

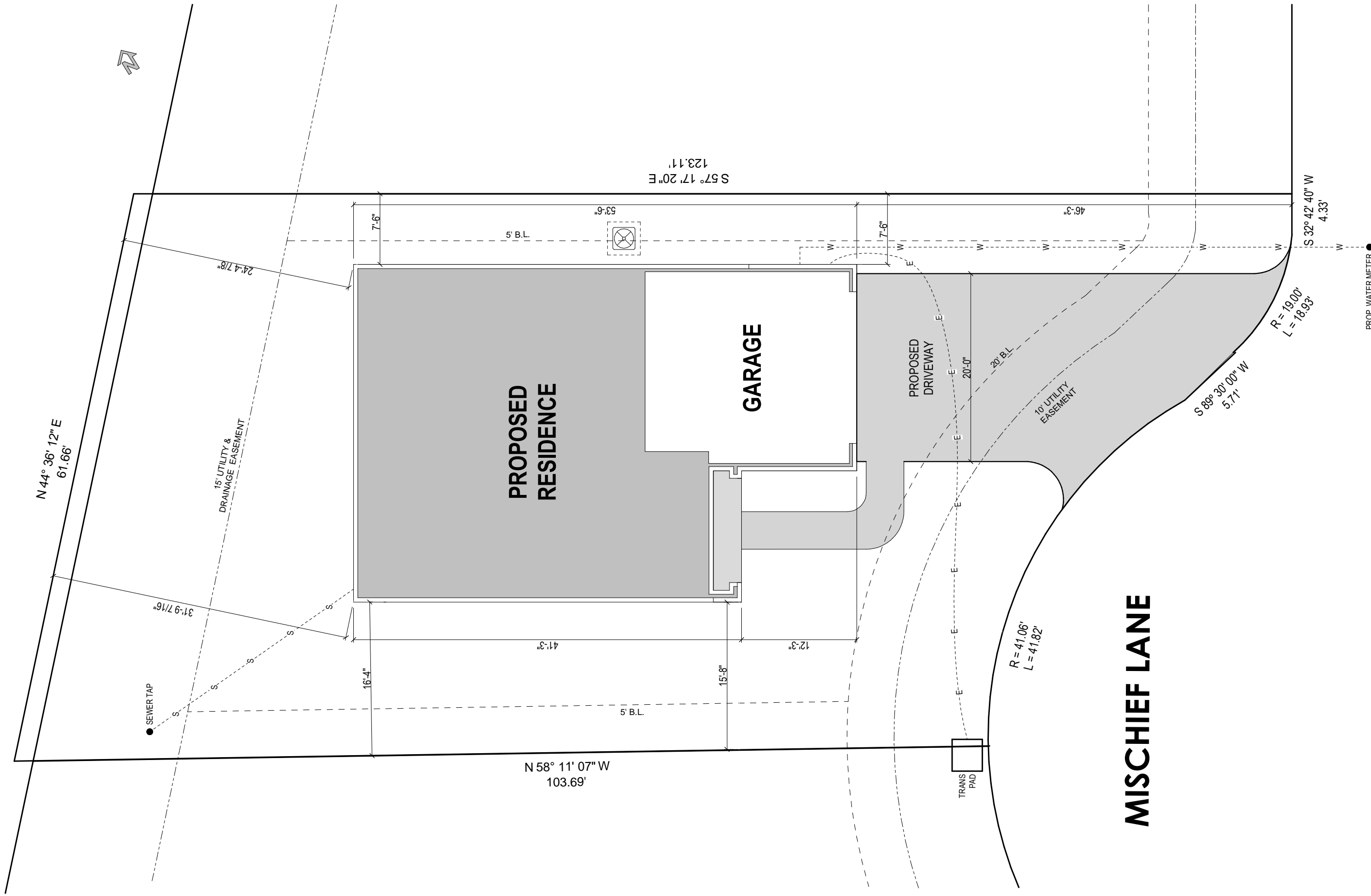

MISCHIEFF LANE

LOT 12, BLOCK A, CHANDLER'S LANDING PHASE 20
 118 MISCHIEFF LANE, ROCKWALL, TX, 75032

1 SITE PLAN
 1" = 10'-0"

A-SITE
 MR. MAJOR RUSH
 Job #1194397
 Rockwall County



The measurements, dimensions, and other specifications shown on this document are guidelines for construction use only. The actual specifications of the finished structure may vary. This document may not be relied on as representation of what the completed structure will look like.

FC- 9/10/2019 - MD
 RD- 03/17/2019 - SL
 PERMIT- 05/12/2020 - SL
 CHKOUT- 04/27/2020 - ZO

FINAL PLANS
 4031
 GOLIAD A

Tilson Home Corporation 2019 ©

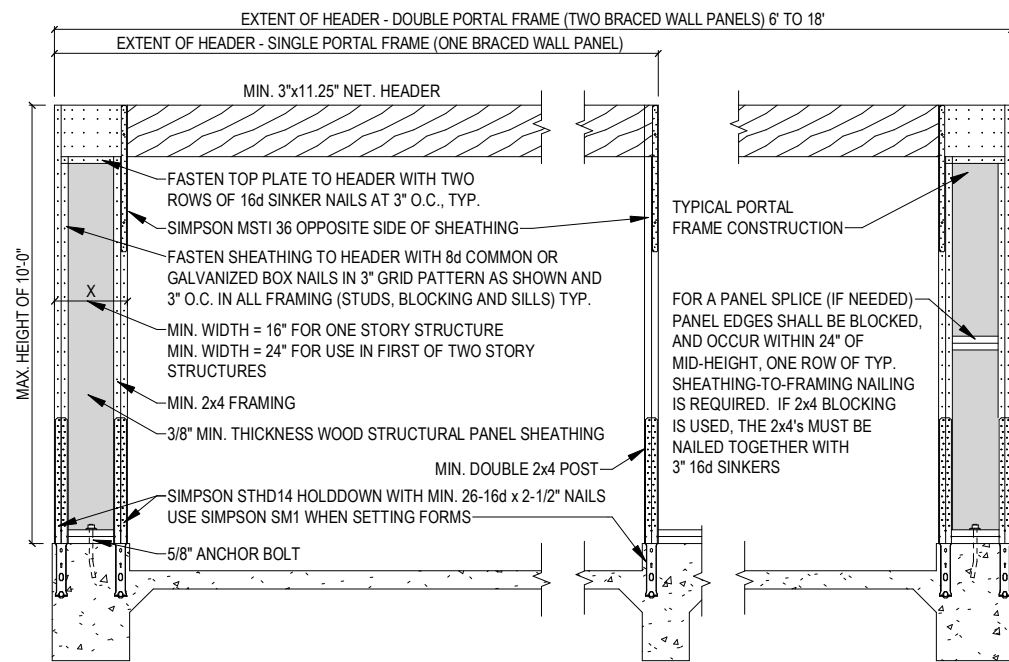

2 PORTAL FRAMING WITH HOLDDOWNS FOR GARAGE DOOR OPENINGS
1/8" = 1'-0"

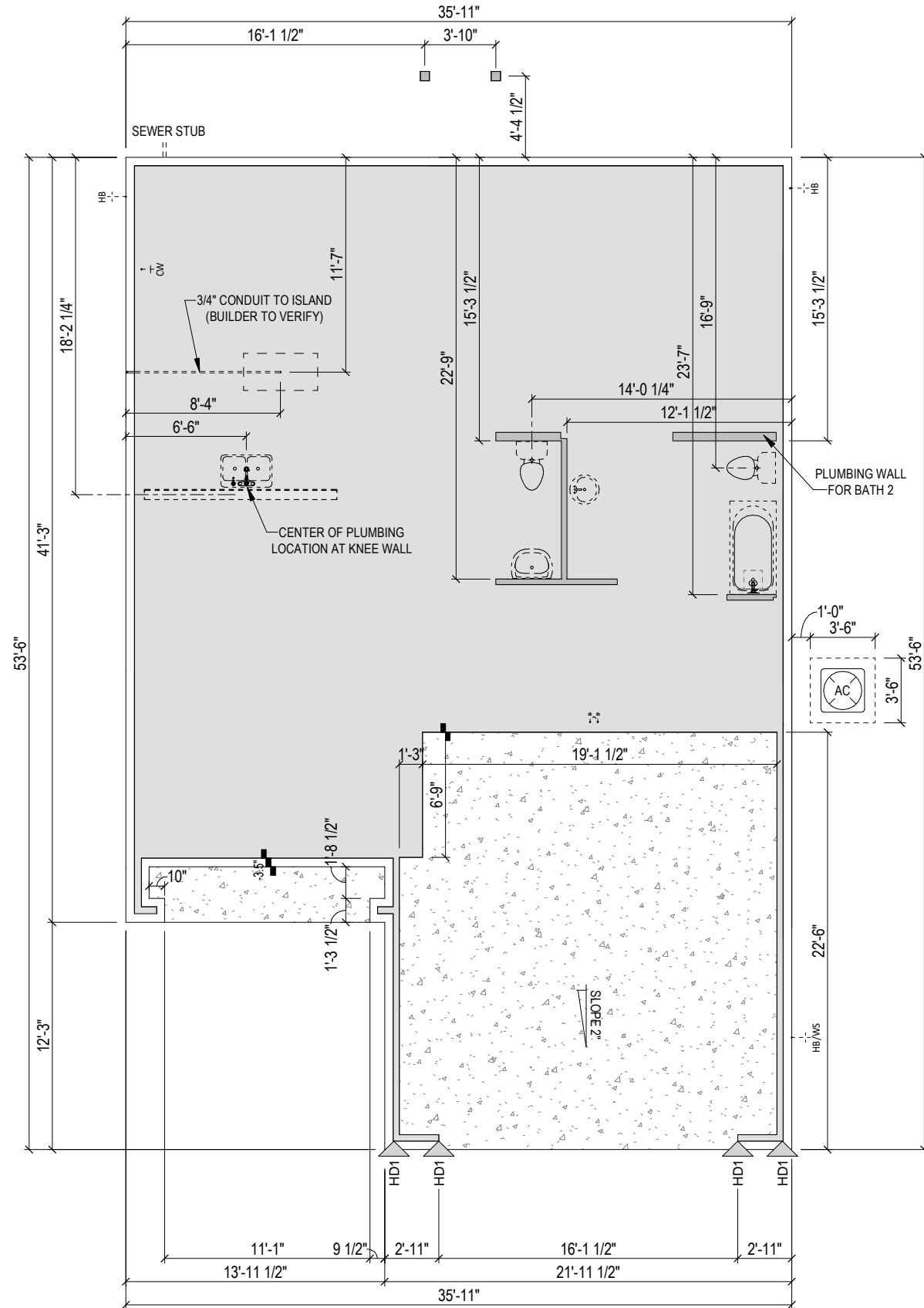

1 SLAB PLAN
1/8" = 1'-0"

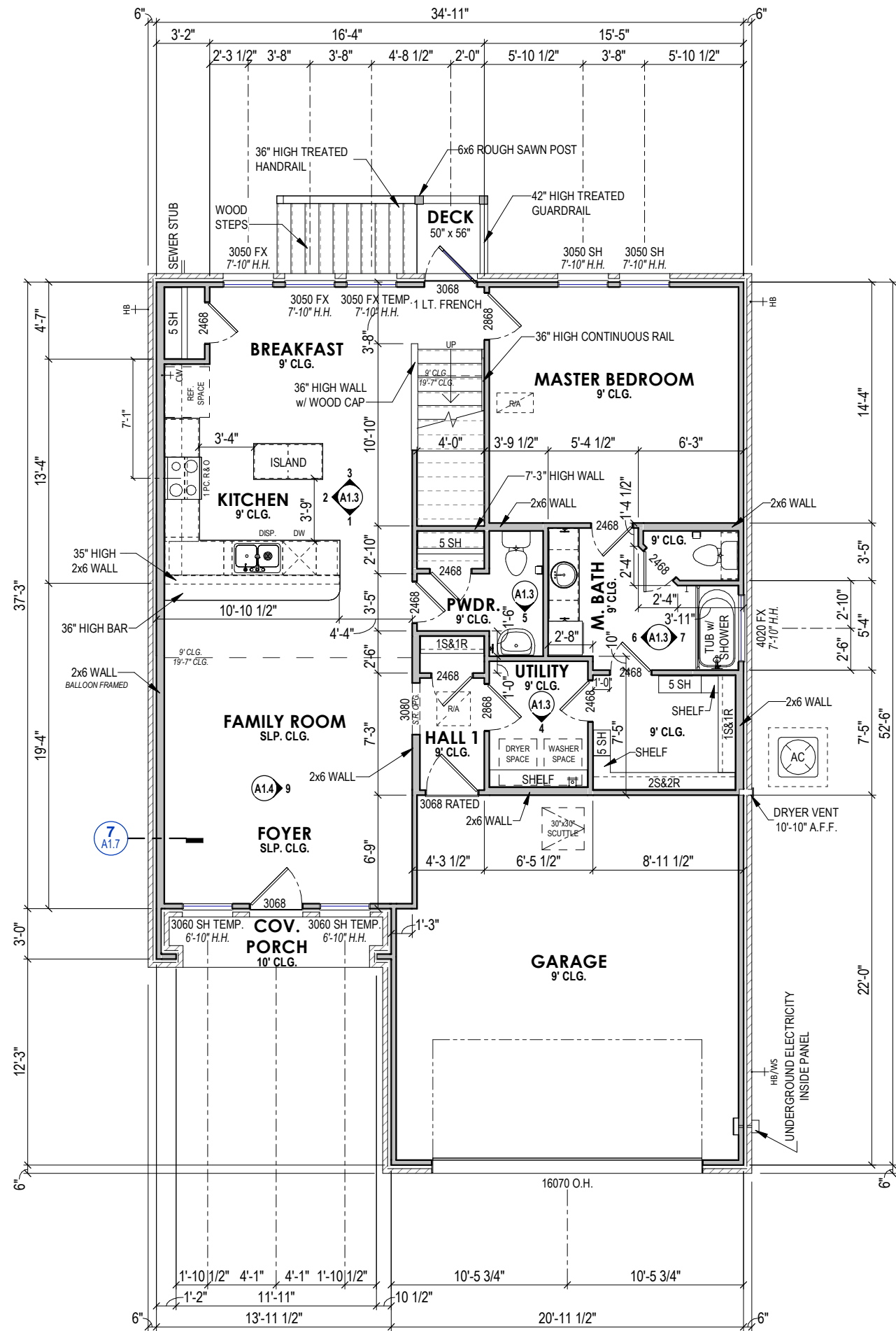

- FLOOR PLAN NOTES**
- BATH ACCESSORIES:**
(HEIGHT TO BE BLOCKED & MOUNTED)
- TOWEL BARS - 54" A.F.F.
 - TOILET PAPER HOLDER - 28" A.F.F.
 - ROBE HOOK - 72" A.F.F.
 - TOWEL RING - 60" A.F.F.
 - SHOWER ROD - 58" ABV. TUB DECK
- PLUMBING:**
- RANGE GAS SHUT-OFF VALVE (IF APPLICABLE) TO BE LOCATED IN ADJACENT CABINET
- HVAC:**
- FRESH AIR INTAKE SHALL BE VENTED THROUGH SOFFIT OR GABLE WALL
- WATER HEATER:**
- IF LOCATED IN ATTIC: PROVIDE PAN AND DRAIN
 - IF GAS & LOCATED IN CLOSET: WEATHERSTRIP DOOR, PROVIDE OUTSIDE COMBUSTIBLE AIR, & INSULATE WALLS
- GARAGE (IF APPLICABLE):**
- SEE SPECS FOR FINISH

FINAL PLANS
4031
GOLIAD A

EC- 9/10/2019 - MD
RD- 03/17/2019 - SL
PERMIT- 05/12/2020 - SL
CHKOUT- 04/27/2020 - ZO

The measurements, dimensions, and other specifications shown on this document are guidelines for construction use only. The actual specifications of the finished structure may vary. This document may not be relied on as representation of what the completed structure will look like.

TILSON
CUSTOM HOME BUILDERS

Tilson Home Corporation 2019 ©

MR. MAJOR RUSH
Job #1194397
Rockwall County

A1.1

1 1ST FLOOR PLAN
1/8" = 1'-0"

ROOM FINISH SCHEDULE

Name	Ceiling Height	Crown Mould Type	Chair Rail
1ST FLOOR			
BREAKFAST	9'	(none)	
FAMILY ROOM	SLP.	(none)	
FOYER	SLP.	(none)	
GARAGE	9'	(none)	
HALL 1	9'	(none)	
HALL 1 CLOSET	9'	(none)	
KITCHEN	9'	(none)	
MASTER BATH	9'	(none)	
MASTER BATH WATER CLOSET	9'	(none)	
MASTER BEDROOM	9'	(none)	
MASTER BEDROOM CLOSET	9'	(none)	
PANTRY	9'	(none)	
POWDER	9'	(none)	
POWDER	9'	(none)	
STAIRS		(none)	
UTILITY	9'	(none)	
2ND FLOOR			
BATH 2	9'	(none)	
BEDROOM 2	9'	(none)	
BEDROOM 2 CLOSET	9'	(none)	
BEDROOM 3	9'	(none)	
BEDROOM 3 CLOSET	9'	(none)	
LOFT	9'	(none)	

FLOORING SCHEDULE

Room	Type Comments	Area
Flooring - Carpet & Pad		
Bedroom 2	CARPET	159 SF
Bedroom 2 Closet	CARPET	18 SF
Bedroom 3	CARPET	167 SF
Bedroom 3 Closet	CARPET	26 SF
Family Room	CARPET	226 SF
Loft	CARPET	275 SF
Master Bedroom	CARPET	206 SF
Master Bedroom Closet	CARPET	57 SF
Stairs	CARPET	52 SF
Stairs	CARPET	52 SF
		1239 SF
Flooring - Ceramic Tile		
Bath 2	CERAMIC TILE	42 SF
Breakfast	CERAMIC TILE	118 SF
Foyer	CERAMIC TILE	54 SF
Hall 1	CERAMIC TILE	25 SF
Hall 1 Closet	CERAMIC TILE	8 SF
Kitchen	CERAMIC TILE	109 SF
Master Bath	CERAMIC TILE	50 SF
Master Bath Water Closet	CERAMIC TILE	14 SF
Pantry	CERAMIC TILE	10 SF
Powder	CERAMIC TILE	8 SF
Powder	CERAMIC TILE	37 SF
Utility	CERAMIC TILE	43 SF
		518 SF

NOTE: FLOORING LAYOUT SHOWN IS FOR ILLUSTRATION PURPOSES ONLY. SEE OPTIONS ADDENDUM FOR JOB SPECIFIC LAYOUT.

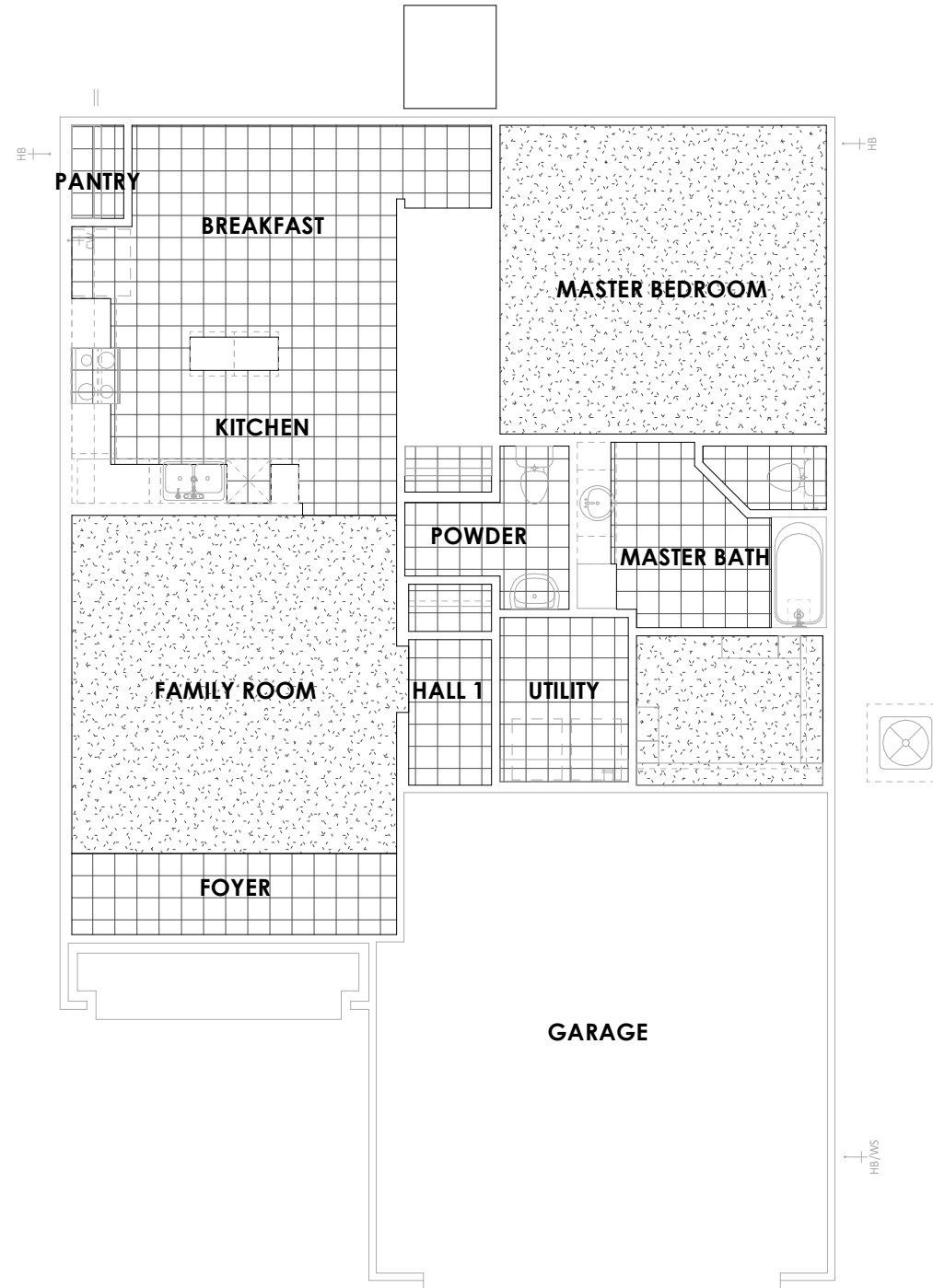

1 1ST FLOOR ROOM FINISH PLAN
1/8" = 1'-0"

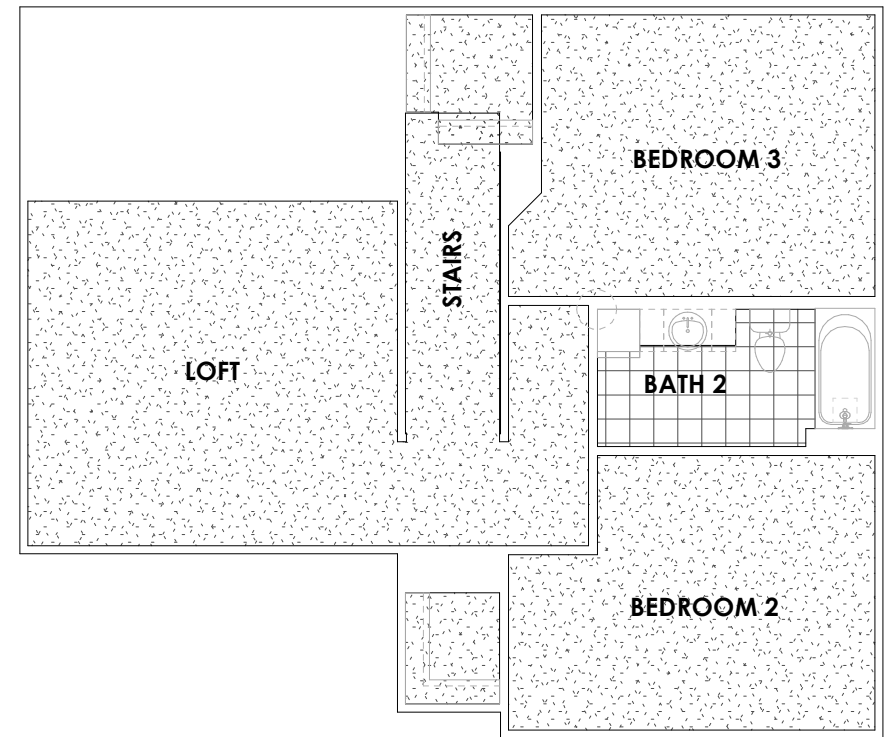

2 2ND FLOOR ROOM FINISH PLAN
1/8" = 1'-0"

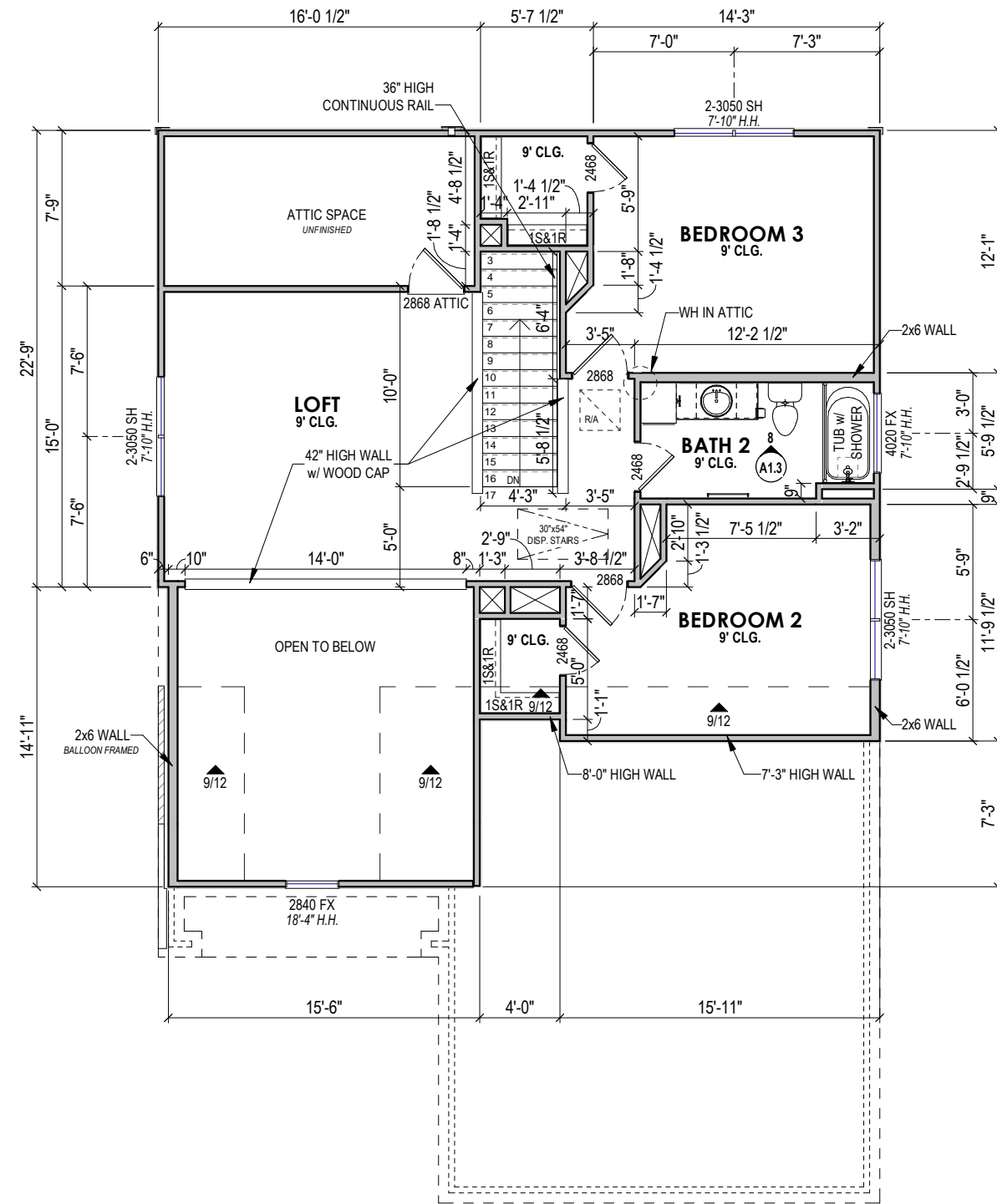

- FLOOR PLAN NOTES**
- BATH ACCESSORIES:**
(HEIGHT TO BE BLOCKED & MOUNTED)
- TOWEL BARS - 54" A.F.F.
 - TOILET PAPER HOLDER - 28" A.F.F.
 - ROBE HOOK - 72" A.F.F.
 - TOWEL RING - 60" A.F.F.
 - SHOWER ROD - 58" ABV. TUB DECK
- PLUMBING:**
- RANGE GAS SHUT-OFF VALVE (IF APPLICABLE) TO BE LOCATED IN ADJACENT CABINET
- HVAC:**
- FRESH AIR INTAKE SHALL BE VENTED THROUGH SOFFIT OR GABLE WALL
- WATER HEATER:**
- IF LOCATED IN ATTIC: PROVIDE PAN AND DRAIN
 - IF GAS & LOCATED IN CLOSET: WEATHERSTRIP DOOR, PROVIDE OUTSIDE COMBUSTIBLE AIR, & INSULATE WALLS
- GARAGE (IF APPLICABLE):**
- SEE SPECS FOR FINISH

1 2ND FLOOR PLAN
1/8" = 1'-0"

FINAL PLANS
4031
GOLIAD A

EC- 9/10/2019 - MD
RD- 03/17/2019 - SL
PERMIT- 05/12/2020 - SL
CHKOUT- 04/27/2020 - ZO

The measurements, dimensions, and other specifications shown on this document are guidelines for construction use only. The actual specifications of the finished structure may vary. This document may not be relied on as representation of what the completed structure will look like.

TILSON
CUSTOM HOME BUILDERS

Tilson Home Corporation, 2019 ©

MR. MAJOR RUSH
Job #1194397
Rockwall County

A1.2

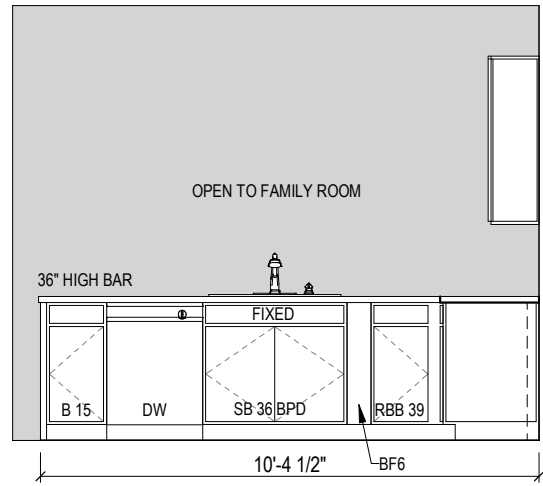

1 KITCHEN - SINK WALL
1/4" = 1'-0"

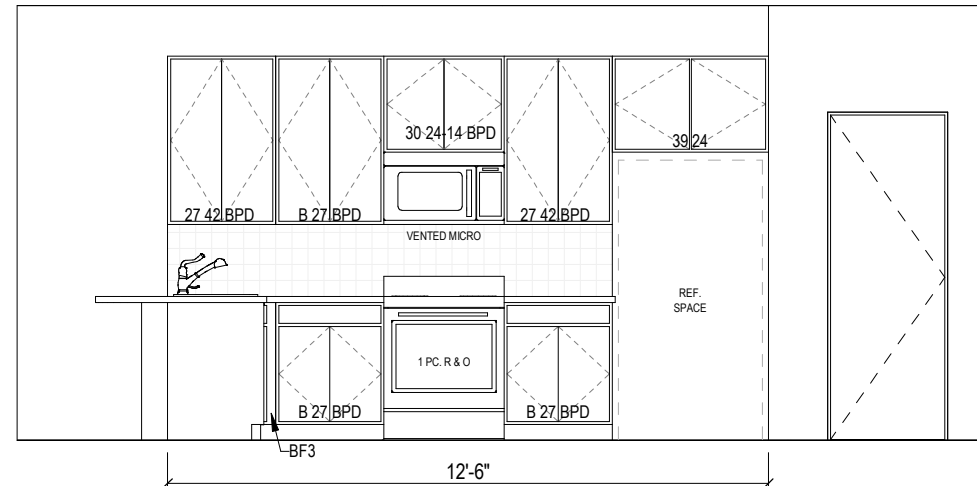

2 KITCHEN - RANGE WALL
1/4" = 1'-0"

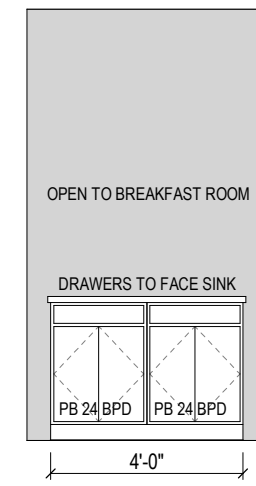

3 KITCHEN ISLAND
1/4" = 1'-0"

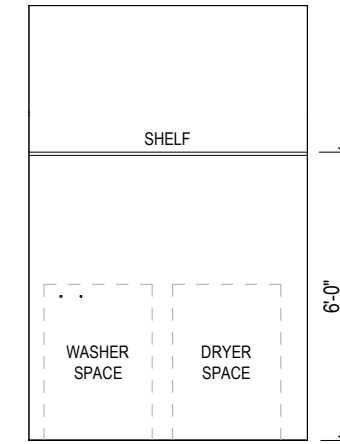

4 UTILITY
1/4" = 1'-0"

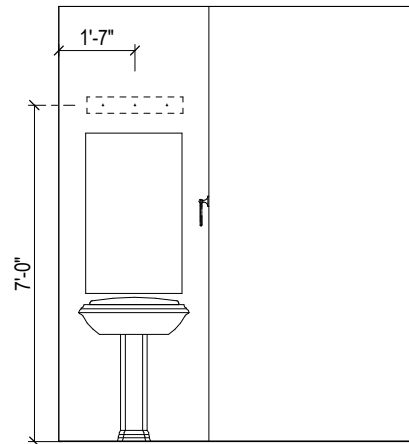

5 POWDER
1/4" = 1'-0"

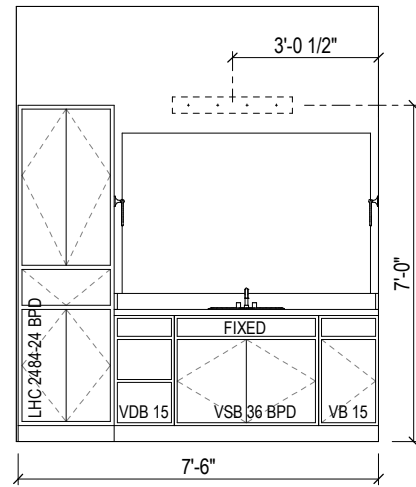

6 MASTER BATH
1/4" = 1'-0"

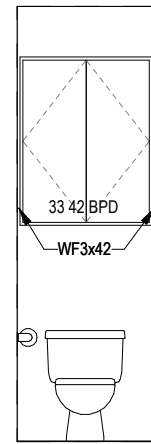

7 MASTER BATH - WC
1/4" = 1'-0"

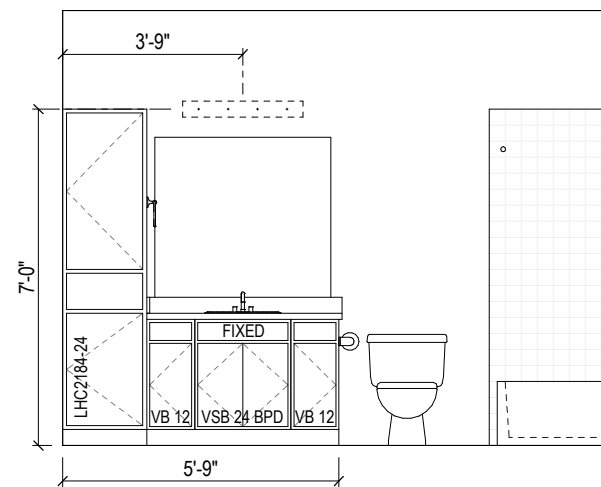

8 BATH 2
1/4" = 1'-0"

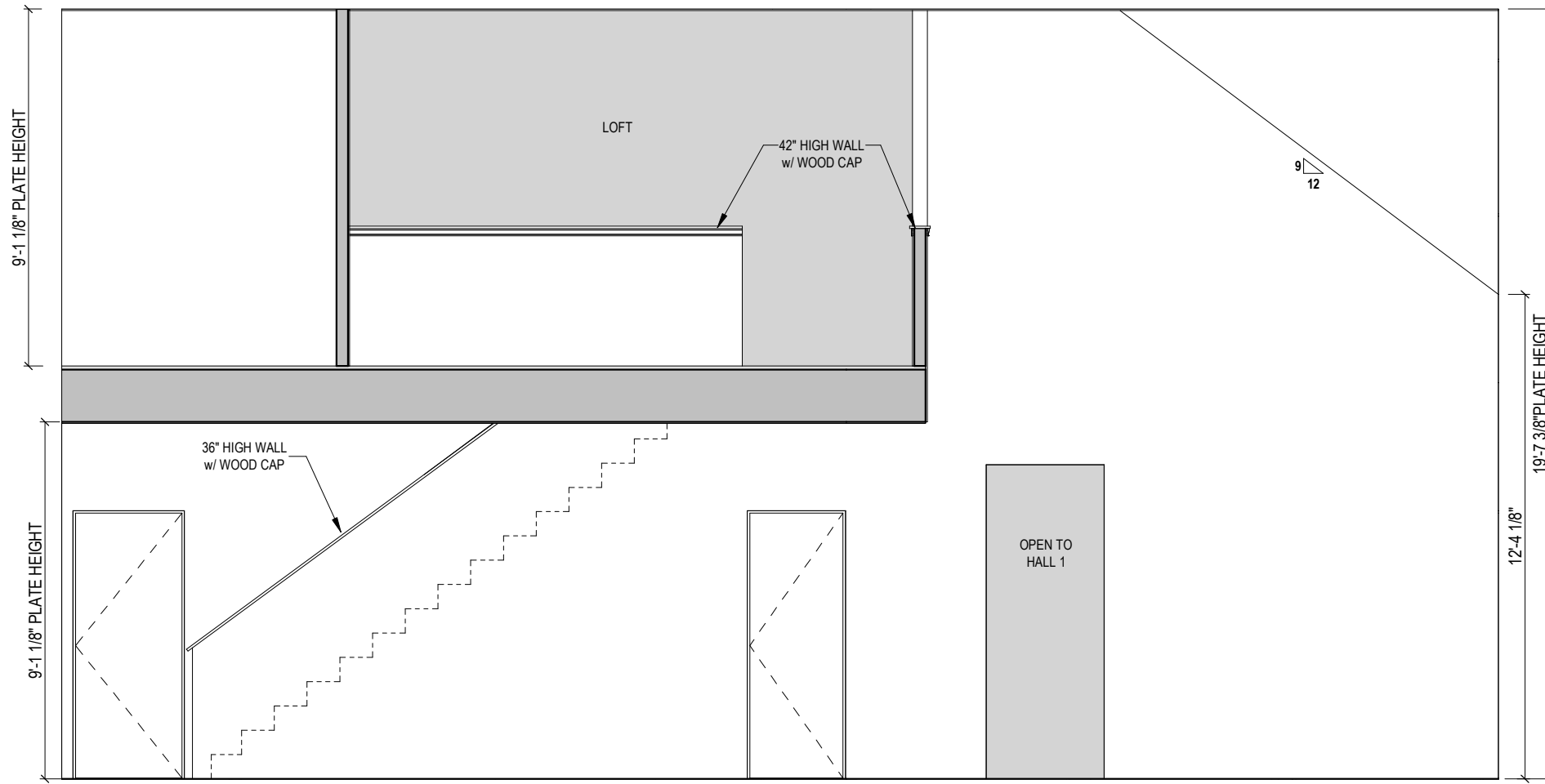

9 STAIR WALL
1/4" = 1'-0"

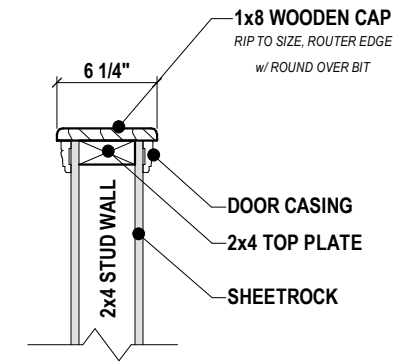

KNEE WALL DETAIL

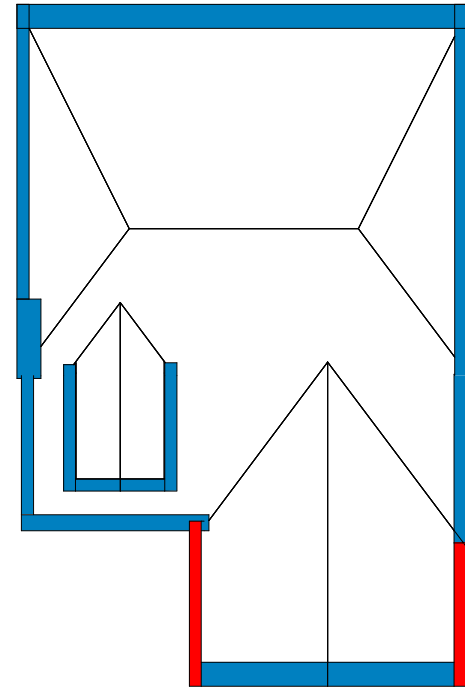
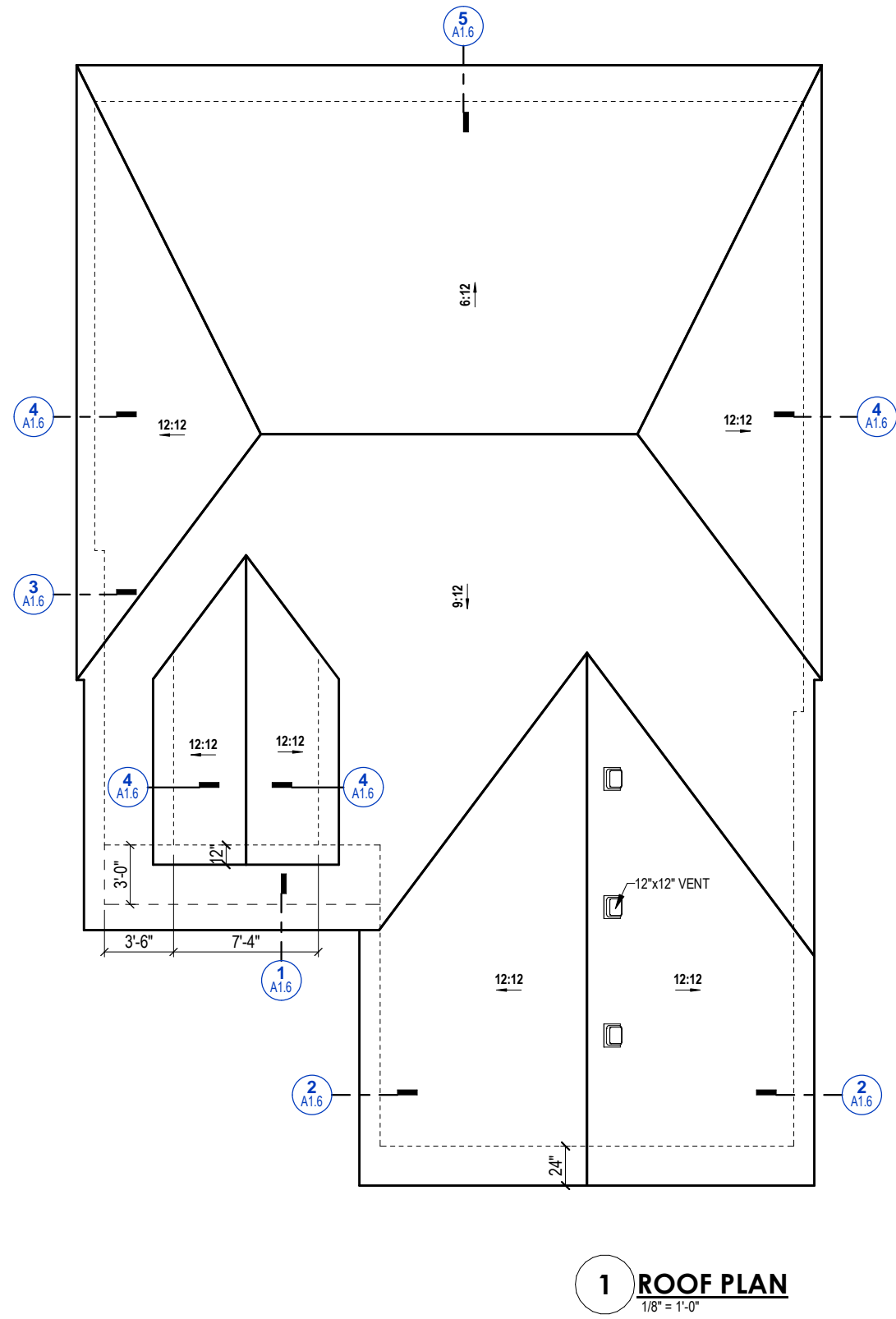

SOFFIT LEGEND

	VENTED SOFFIT
	NON VENTED SOFFIT

MR. MAJOR RUSH
Job #1194397
Rockwall County

A1.5

TILSON
CUSTOM HOME BUILDERS

Tilson Home Corporation 2019 ©

The measurements, dimensions, and other specifications shown on this document are guidelines for construction use only. The actual specifications of the finished structure may vary. This document may not be relied on as representation of what the completed structure will look like.

FC- 9/10/2019 - MD
RD- 03/17/2019 - SL
PERMIT- 05/12/2020 - SL
CHKOUT- 04/27/2020 - ZO

FINAL PLANS
4031
GOLIAD A

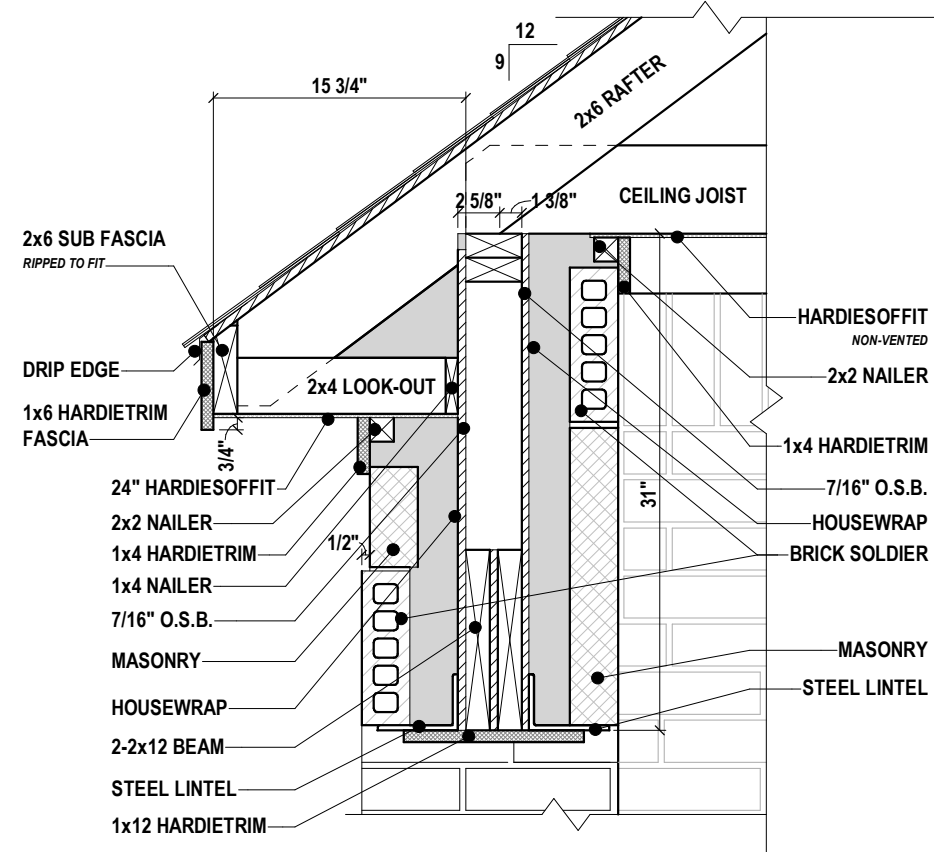

1 FRONT PORCH CORNICE
1" = 1'-0"

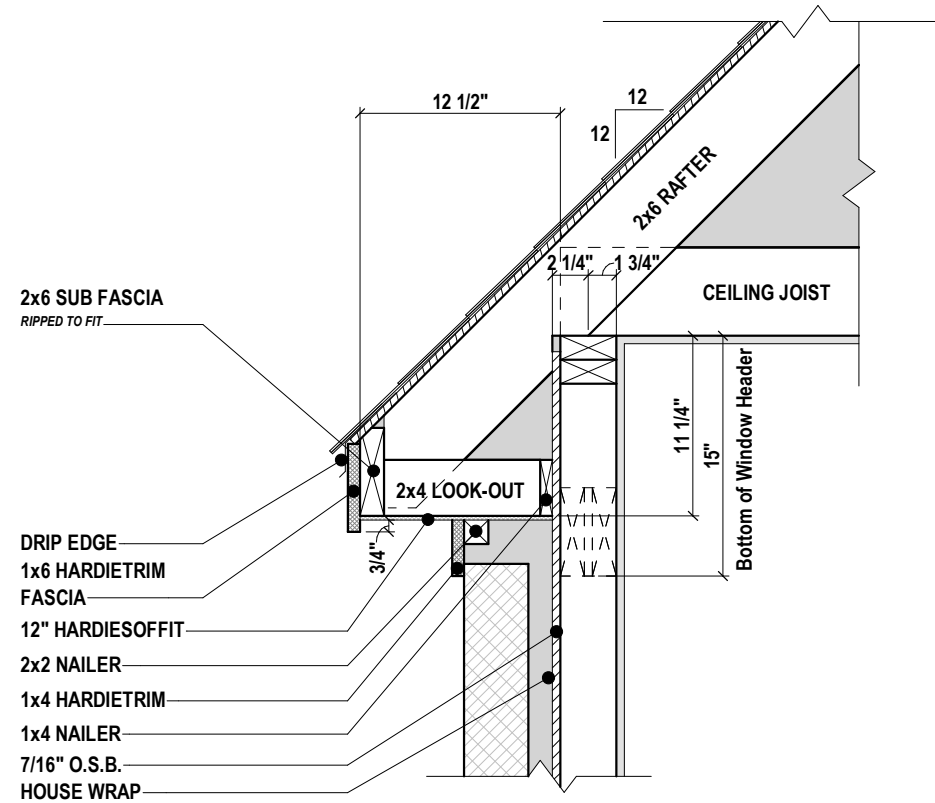

2 12-12 MASONRY CORNICE
1" = 1'-0"

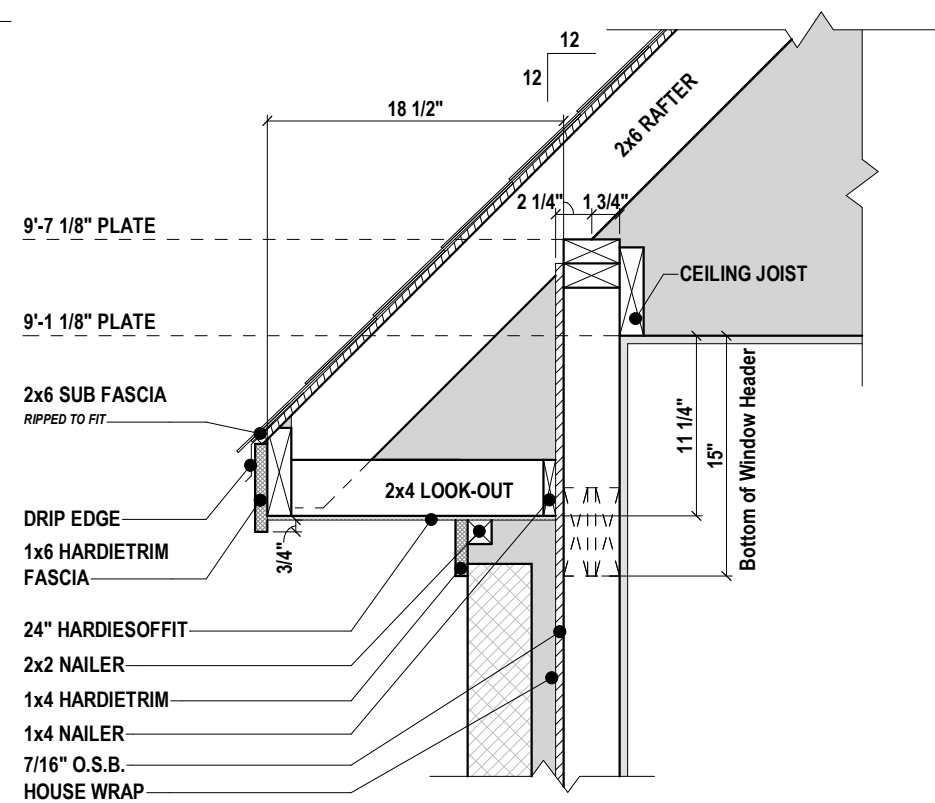

3 12-12 MASONRY CORNICE
1" = 1'-0"

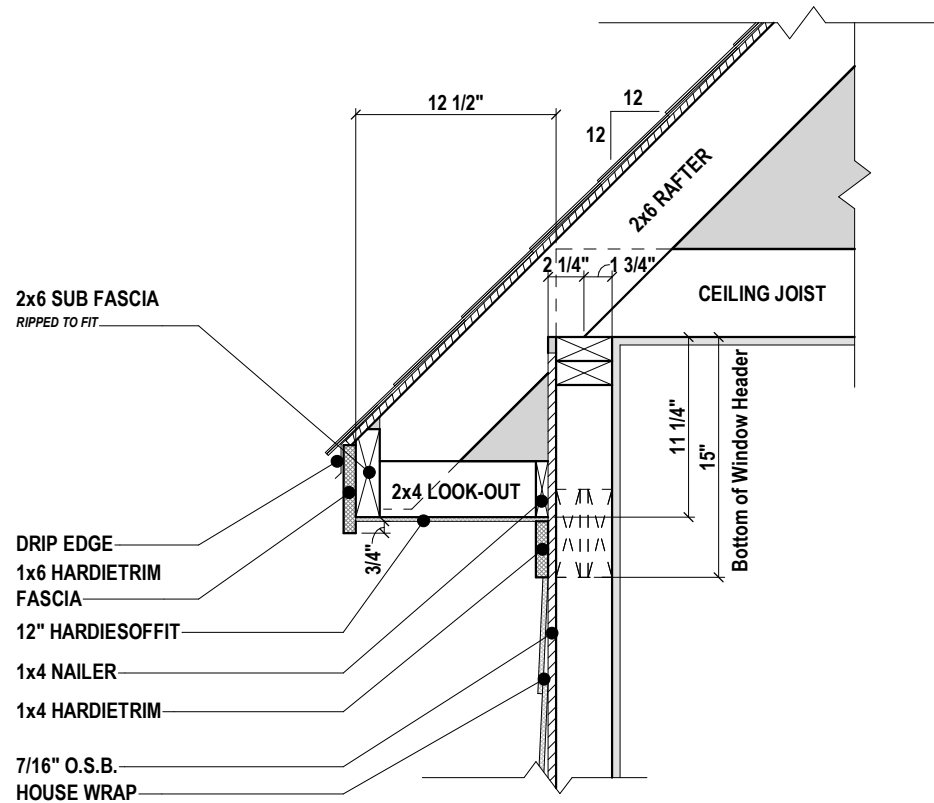

4 12-12 CORNICE
1" = 1'-0"

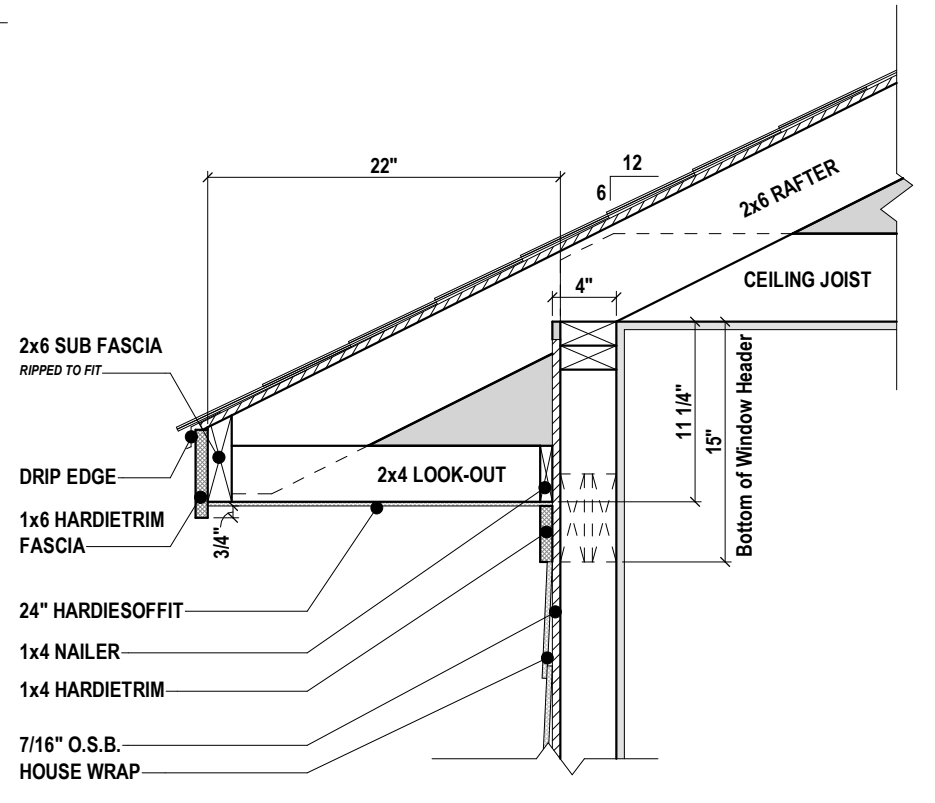

5 6-12 CORNICE
1" = 1'-0"

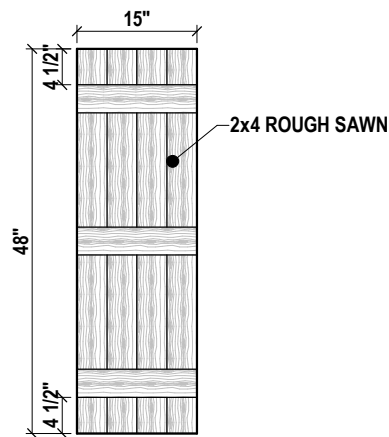

6 SHUTTER DETAIL
1/2" = 1'-0"

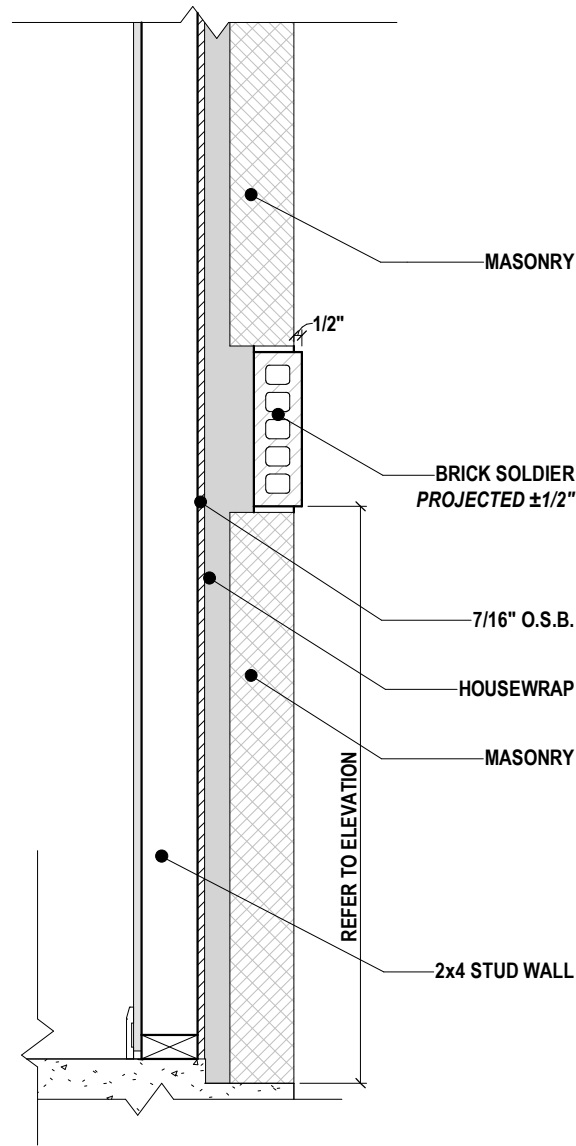

7 BRICK SOLDIER DETAIL
1" = 1'-0"

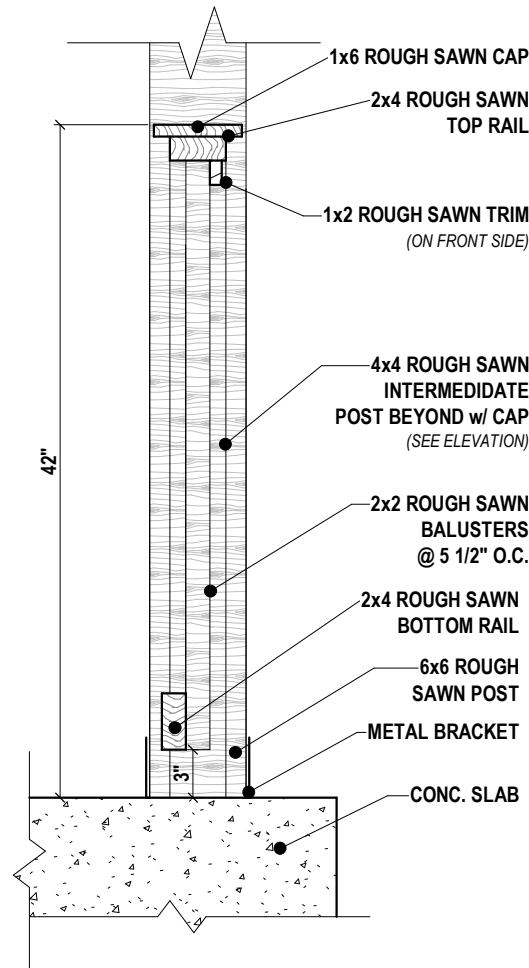

8 CONCRETE PORCH RAIL DETAIL
1" = 1'-0"

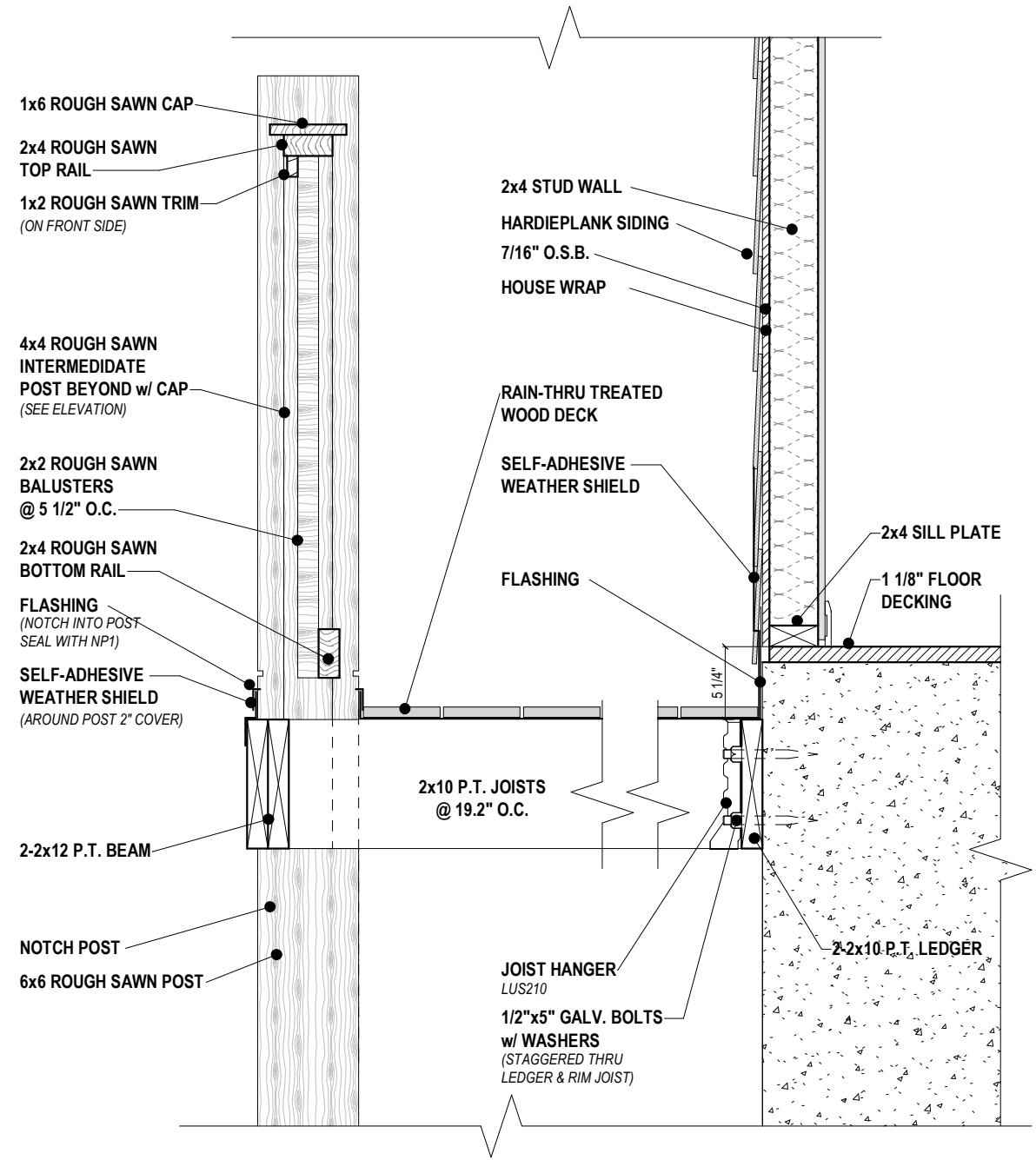

9 WALK - OUT DECK DETAIL
1" = 1'-0"



Z2020-034- SUP FOR 118 MISCHIEF LANE
ZONING - LOCATION MAP =



City of Rockwall

Planning & Zoning Department
385 S. Goliad Street
Rockwall, Texas 75032
(P): (972) 771-7745
(W): www.rockwall.com

The City of Rockwall GIS maps are continually under development and therefore subject to change without notice. While we endeavor to provide timely and accurate information, we make no guarantees. The City of Rockwall makes no warranty, express or implied, including warranties of merchantability and fitness for a particular purpose. Use of the information is the sole responsibility of the user.





City of Rockwall

Planning & Zoning Department
385 S. Goliad Street
Rockwall, Texas 75087
(P): (972) 771-7745
(W): www.rockwall.com

The City of Rockwall GIS maps are continually under development and therefore subject to change without notice. While we endeavor to provide timely and accurate information, we make no guarantees. The City of Rockwall makes no warranty, express or implied, including warranties of merchantability and fitness for a particular purpose. Use of the information is the sole responsibility of the user.

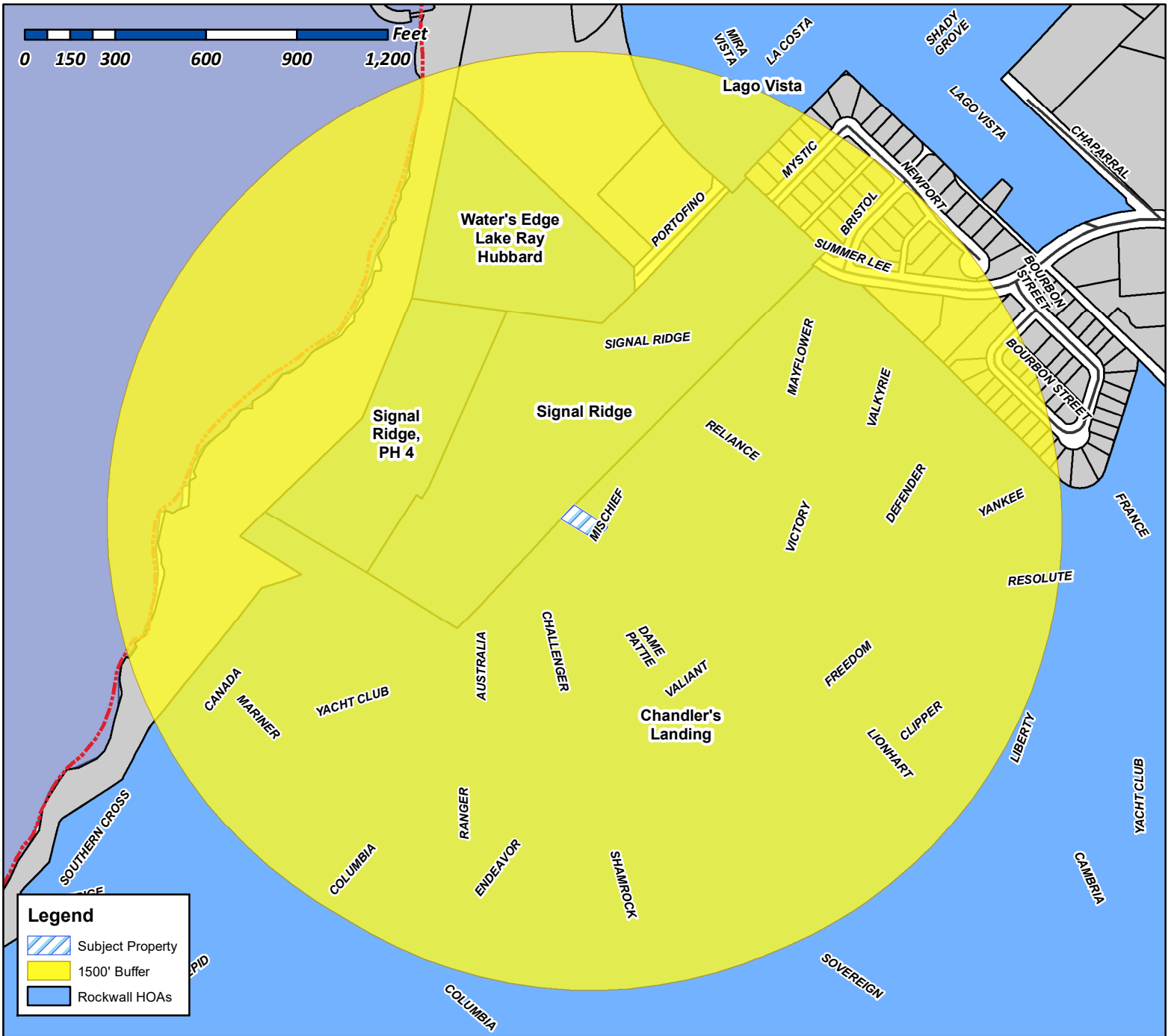

Case Number: Z2020-034
Case Name: SUP for 118 Mischief Lane
Case Type: Zoning
Zoning: Planned Development District 8 (PD-8)
Case Address: 118 Mischief Lane

Date Created: 8/14/2020
 For Questions on this Case Call (972) 771-7745

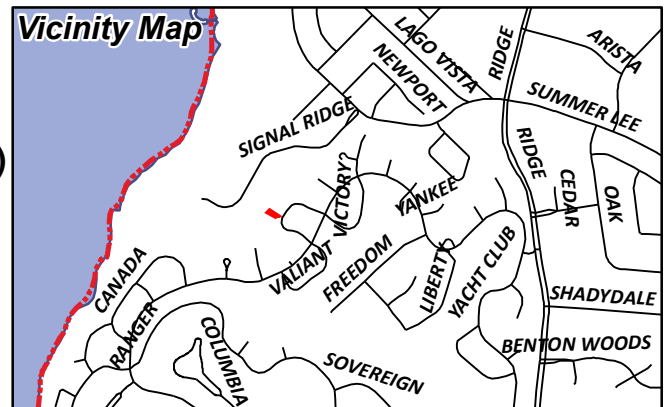



City of Rockwall

Planning & Zoning Department
385 S. Goliad Street
Rockwall, Texas 75087
(P): (972) 771-7745
(W): www.rockwall.com

The City of Rockwall GIS maps are continually under development and therefore subject to change without notice. While we endeavor to provide timely and accurate information, we make no guarantees. The City of Rockwall makes no warranty, express or implied, including warranties of merchantability and fitness for a particular purpose. Use of the information is the sole responsibility of the user.

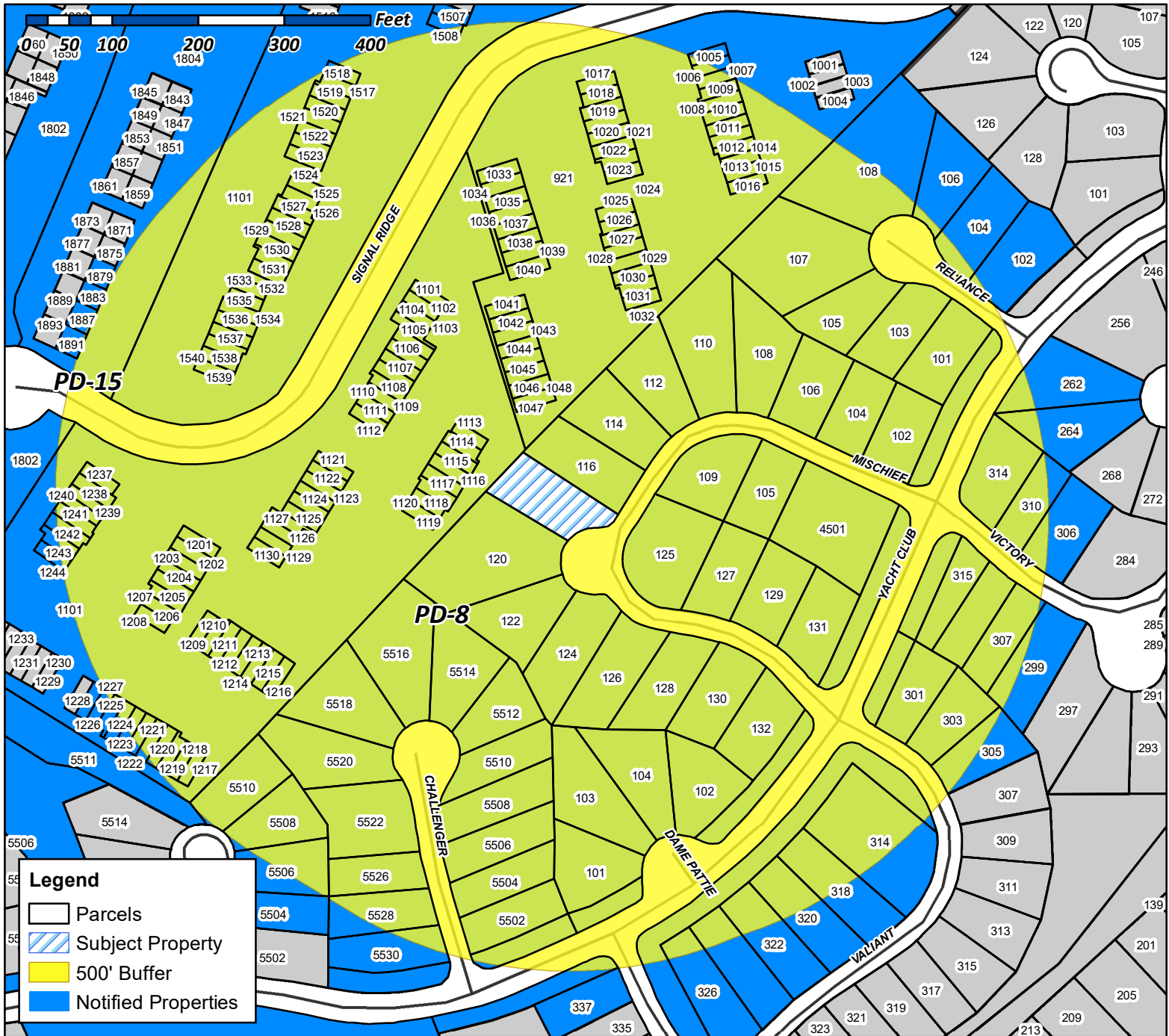

Case Number: Z2020-034
Case Name: SUP for 118 Mischief Lane
Case Type: Zoning
Zoning: Planned Development District 8 (PD-8)
Case Address: 118 Mischief Lane

Date Created: 8/14/2020
For Questions on this Case Call (972) 771-7745



MARICH ENTERPRISE CORPORATION
1005 SIGNAL RIDGE
ROCKWALL, TX 75032

SEPEHRI SUSAN M
1006 SIGNAL RIDGE PLACE
ROCKWALL, TX 75032

BROYLES STEPHANIE
1007 SIGNAL RIDGE PL
ROCKWALL, TX 75032

CHAPMAN PAMELA JEAN
1008 SIGNAL RIDGE
ROCKWALL, TX 75032

MIEROW SHARON A
1009 SIGNAL RIDGE PL
ROCKWALL, TX 75032

MAFFEI DIEGO R & GERTRAUD A
101 DAME PATTIE DR
ROCKWALL, TX 75032

GOODSON JOSEPH F & SONJA R
101 RELIANCE CT
ROCKWALL, TX 75032

HIGGINS MICHAEL R AND ANN S
1010 SIGNAL RIDGE
ROCKWALL, TX 75032

FOREMAN JANET
1011 SIGNAL RIDGE PL
ROCKWALL, TX 75032

ESTILL KENNETH W & CONNIE R
1012 SIGNAL RIDGE PL
ROCKWALL, TX 75032

MOORE GREGORY J
1013 SIGNAL RIDGE
ROCKWALL, TX 75032

ROBERTSON GERALDINE C &
LANCE STANFORD ROBERTSON
1014 SIGNAL RIDGE
ROCKWALL, TX 75032

BCL REAL ESTATE LLC
1015 SIGNAL RIDGE
ROCKWALL, TX 75032

GRAGG CAROL
1016 SIGNAL RIDGE PL
ROCKWALL, TX 75032

VANGUARD PORTABLE SOLUTIONS INC
1017 NATIVE TR
HEATH, TX 75032

GARDNER DAVID L REV LIV TR
1017 SIGNAL RIDGE
ROCKWALL, TX 75032

TROTTER STEVEN D
1018 SIGNAL RIDGE PL
ROCKWALL, TX 75032

AMHILL FINANCIAL LP
ATTN JIM PETERS
1019 SIGNAL RIDGE
ROCKWALL, TX 75032

MUSSER MARTIN C
102 DAME PATTIE DR
ROCKWALL, TX 75032

BADEAUX BRYAN A JR AND MARTHA D
102 MISCHIEF LN
ROCKWALL, TX 75032

CHENAULT JOSH & NATHALIE
102 RELIANCE COURT
ROCKWALL, TX 75032

WAGNER JULIE A
1020 SIGNAL RIDGE PLACE
ROCKWALL, TX 75032

CHAMBERLIN PROPERTIES LLC
1021 SIGNAL RIDGE
ROCKWALL, TX 75032

DAFFRON JAMES R SR & ANDREA
1022 SIGNAL RIDGE PL
ROCKWALL, TX 75032

HAIL CHRIS & MELODY
1023 SIGNAL RIDGE
ROCKWALL, TX 75032

VAIL SYDNEY
1024 SIGNAL RIDGE PL
ROCKWALL, TX 75032

MCMURTRE DREW
1025 SIGNAL RIDGE
ROCKWALL, TX 75032

WHITE RANDY
1026 SIGNAL RIDGE PL
ROCKWALL, TX 75032

MCPARTLAND MARY C
1027 SIGNAL RIDGE PL
ROCKWALL, TX 75032

ALVARADO KRESHA
1028 SIGNAL RIDGE
ROCKWALL, TX 75032

PRESTON DEWEY D & NANNETTE
1029 SIGNAL RIDGE
ROCKWALL, TX 75032

SPURLOCK BRENDA CAROL
10297 CR 540
LAVON, TX 75166

THOMAS VELIA
103 DAME PATTIE
ROCKWALL, TX 75032

BCL REAL ESTATE LLC
103 GROSS RD
MESQUITE, TX 75149

SINCLAIR SHERI JENE & SUE
103 RELIANCE CT
ROCKWALL, TX 75032

LIBERTY TRUST COMPANY LTD
CUSTODIAN FBO WILLIAM COMPTON
1030 SIGNAL RIDGE
ROCKWALL, TX 75032

LIBERTY TRUST COMPANY LTD
CUSTODIAN FBO WILLIAM COMPTON IRA
#TC005612
1031 SIGNAL RIDGE PLACE
ROCKWALL, TX 75032

PERROTTA SHARON
1032 SIGNAL RIDGE PL
ROCKWALL, TX 75032

JOHNSTON SHARRON
1033 SIGNAL RIDGE PLACE
ROCKWALL, TX 75032

BURKETT MARY REBECCA EASON
1034 SIGNAL RIDGE
ROCKWALL, TX 75032

FALLS DAVID & TERRI
1035 SIGNAL RIDGE
ROCKWALL, TX 75032

BOYD KENNETH
1036 SIGNAL RIDGE PL
ROCKWALL, TX 75032

GORDON NANCY ARAKAKI
1037 SIGNAL RIDGE
ROCKWALL, TX 75032

BEVILL HELEN M AND
CHANDRA KARLEN
1038 SIGNAL RIDGE
ROCKWALL, TX 75032

BCL REAL ESTATE LLC
ATTN:TOM LORENZ
1039 SIGNAL RIDGE
ROCKWALL, TX 75032

FAYAD HUSSIAN AND
ALISSA JENKINS
104 DAME PATTIE DRIVE
ROCKWALL, TX 75032

HAYES BRANDON E
104 MISCHIEF
ROCKWALL, TX 75032

VANGUARD PORTABLE SOLUTIONS INC
104 RELIANCE
ROCKWALL, TX 75032

ARMSTRONG D
1040 SIGNAL RIDGE
ROCKWALL, TX 75032

BREZ RAYMOND C & M LYNNE TRUSTEES
BREZ FAMILY TRUST
1041 SIGNAL RIDGE
ROCKWALL, TX 75032

ARMSTRONG D
1042 SIGNAL RIDGE
ROCKWALL, TX 75032

NICHOLS JANET
1043 SIGNAL RIDGE PL
ROCKWALL, TX 75032

TRINGALI CAHTERINE
1044 SIGNAL RIDGE PL
ROCKWALL, TX 75032

BCL REAL ESTATE LLC
1045 SIGNAL RIDGE
ROCKWALL, TX 75032

YANGER LISA
1046 SIGNAL RIDGE PL
ROCKWALL, TX 75032

ARMSTRONG JOHN D III AND INDIVIDUAL
1047 SIGNAL RIDGE
ROCKWALL, TX 75032

ZAJDL SALLY A
1048 SIGNAL RIDGE PL
ROCKWALL, TX 75032

JOHNSON ROBERT & DOLORES
105 MISCHIEF LN
ROCKWALL, TX 75032

HAYES BRANDON
105 RELIANCE CT
ROCKWALL, TX 75032

GRAF DANIEL & JESSICA
106 MISCHIEF LANE
ROCKWALL, TX 75032

DOWLING STEVEN & BRENDA
106 RELIANCE CT
ROCKWALL, TX 75032

TOVAR ADAN AND CAROLYNN JEWELL MALICK-
GILBREATH
107 RELIANCE CT
ROCKWALL, TX 75032

CARRILLO VICTOR G
108 MISCHIEF LN
ROCKWALL, TX 75032

PETERSEN CARL S & WENDY
108 RELIANCE CT
ROCKWALL, TX 75032

HAGIN GARY L & W ANNE
109 MISCHIEF LN
ROCKWALL, TX 75032

DILOV VANIO
110 MISCHIEF
ROCKWALL, TX 75032

FULTZ PEGGY J & TOMMY G
1101 SIGNAL RIDGE PL
ROCKWALL, TX 75032

BCL REAL ESTATE LLC
1102 SIGNAL RIDGE
ROCKWALL, TX 75032

HARRIS SUSAN
1103 SIGNAL RIDGE
ROCKWALL, TX 75032

GARZA OLIVIA L AND FIDENCIO
1104 SIGNAL RIDGE #1104
ROCKWALL, TX 75032

GARDNER DAVID L REV LIV TR
1105 51ST ST W
BRADENTON, FL 34209

DAVID L GARDNER REVOCABLE LIVING TRUST
1105 51ST ST W
BRADENTON, FL 34209

DAVIS ROBERT NEAL
1105 MELISSA LN
GARLAND, TX 75040

LARAPINTA LLC
1105 SIGNAL RIDGE
ROCKWALL, TX 75032

OGLIN THOMAS J & JOYCE L
1106 SIGNAL RIDGE PL
ROCKWALL, TX 75032

PARNES DROR & ALEXANDRA
1107 SIGNAL RIDGE
ROCKWALL, TX 75032

CHAMBERLIN PROPERTIES LLC
1108 SIGNAL RIDGE
ROCKWALL, TX 75032

BCL REAL ESTATE LLC
1109 SIGNAL RIDGE
ROCKWALL, TX 75032

BURKETT REBECCA SHANNON
MARY R BURKETT CUSTODIAN
1111 SIGNAL RIDGE
ROCKWALL, TX 75032

TWOMEY ELIZABETH A
1112 SIGNAL RIDGE PL
ROCKWALL, TX 75032

BCL REAL ESTATE LLC
1113 SIGNAL RIDGE
ROCKWALL, TX 75032

HOGAN JERRY
1114 SIGNAL RIDGE
ROCKWALL, TX 75032

MATHERNE JUDITH L
1115 SIGNAL RIDGE PL
ROCKWALL, TX 75032

GUZZI CHARLES F & MURIEL Y
1116 SIGNAL RIDGE
ROCKWALL, TX 75032

LEVENTHAL PATRICK J
1118 SIGNAL RIDGE PL
ROCKWALL, TX 75032

METZGER JACQUELINE
1119 SIGNAL RIDGE PL
ROCKWALL, TX 75032

TAN DAVID L AND SHANNON K
112 MISCHIEF LANE
ROCKWALL, TX 75032

LAMAN FRANCES ANN
1120 SIGNAL RIDGE PLACE
ROCKWALL, TX 75032

BURKETT BENJAMIN HERRINGTON E
MARY R BURKETT CUSTODIAN
1121 SIGNAL RIDGE
ROCKWALL, TX 75032

MAYHALL MORGAN
1122 SIGNAL RIDGE PLACE
ROCKWALL, TX 75032

AMHILL FINANCIAL LP
1123 SIGNAL RIDGE
ROCKWALL, TX 75032

PAIGE RYAN PROPERTIES LLC
1124 SIGNAL RIDGE
ROCKWALL, TX 75032

CROW BILL CHARLES & RUTH ELIZABETH
1125 SIGNAL RIDGE
ROCKWALL, TX 75032

YANGER MORRIS ETUX
1126 SIGNAL RIDGE
ROCKWALL, TX 75032

BCL REAL ESTATE LLC
1127 SIGNAL RIDGE
ROCKWALL, TX 75032

VAUGHAN CULLY & SARA
1128 SIGNAL RIDGE PL
ROCKWALL, TX 75032

BCL REAL ESTATE LLC
1129 SIGNAL RIDGE
ROCKWALL, TX 75032

BCL REAL ESTATE LLC
1130 SIGNAL RIDGE
ROCKWALL, TX 75032

GEORGE ELIZABETH M AND ROBIN J
114 MISCHIEF LANE
ROCKWALL, TX 75032

LETT LORNA
116 MISCHIEF LN
ROCKWALL, TX 75032

ROBERTSON GERALDINE C &
LANCE STANFORD ROBERTSON
1170 WATERSIDE CIR
ROCKWALL, TX 75087

COOK NATHAN & COURTNEY
120 MISCHIEF LN
ROCKWALL, TX 75032

BURKETT MARY REBECCA EASON
1201 SIGNAL RIDGE
ROCKWALL, TX 75032

DAVIS ROBERT NEAL
1202 SIGNAL RIDGE
ROCKWALL, TX 75032

CLARKE BEVERLY ANN
1203 SIGNAL RIDGE PL #3
ROCKWALL, TX 75032

DAVID L GARDNER REVOCABLE LIVING TRUST
1204 SIGNAL RIDGE
ROCKWALL, TX 75032

SELZER DEANNA
1205 SIGNAL RIDGE
ROCKWALL, TX 75032

BCL REAL ESTATE LLC
ATTN:TOM LORENZ
1206 SIGNAL RIDGE
ROCKWALL, TX 75032

BURKETT MARY REBECCA
1207 SIGNAL RIDGE
ROCKWALL, TX 75032

ADAMS LINDA RUTH
1208 SIGNAL RIDGE PL
ROCKWALL, TX 75032

BUNYASAI PARIYADA
1209 SIGNAL RIDGE
ROCKWALL, TX 75032

BURKETT MARY REBECCA EASON
1210 SIGNAL RIDGE
ROCKWALL, TX 75032

LANE DEBRA
1211 SIGNAL RIDGE
ROCKWALL, TX 75032

RICHMOND JANET M & TOM R
1212 SIGNAL RIDGE
ROCKWALL, TX 75032

BROWNE STANLEY H & SANDRA R
1213 SIGNAL RIDGE PL
ROCKWALL, TX 75032

DAVID L GARDNER REVOCABLE LIVING TRUST
1214 SIGNAL RIDGE
ROCKWALL, TX 75032

BURKETT MARY R CUSTODIAN
FOR REBECCA SHANNON BURKETT
1215 SIGNAL RIDGE
ROCKWALL, TX 75032

DALE ROBERT WAYNE
1216 SIGNAL RIDGE PL
ROCKWALL, TX 75032

BURKETT MARY R
CUSTODIAN F/BENJAMIN HERRINGTON E
BURKETT
1217 SIGNAL RIDGE
ROCKWALL, TX 75032

BURKETT MARY REBECCA EASON
1218 SIGNAL RIDGE
ROCKWALL, TX 75032

BURKETT REBECCA SHANNON
MARY R BURKETT CUSTODIAN
1219 SIGNAL RIDGE
ROCKWALL, TX 75032

LOWREY COLT A AND
LEO WISE
122 MISCHIEF LN
ROCKWALL, TX 75032

BURKETT MARY REBECCA EASON
1220 SIGNAL RIDGE
ROCKWALL, TX 75032

LASAGE TAMMY
1221 SIGNAL RIDGE PL #1221
ROCKWALL, TX 75032

CHAMBERLIN PROPERTIES LLC
1222 SIGNAL RIDGE
ROCKWALL, TX 75032

DWYER AMY SUZANNE
1223 SIGNAL RIDGE
ROCKWALL, TX 75032

MEYRAT JULIEN BALDRIDGE
1224 SIGNAL RIDGE PL
ROCKWALL, TX 75032

BURKETT BENJAMIN HERRINGTON E
MARY R BURKETT CUSTODIAN
1225 SIGNAL RIDGE
ROCKWALL, TX 75032

RUSSELL VIRGINIA C
1226 SIGNAL RIDGE PL
ROCKWALL, TX 75032

BURKETT REBECCA SHANNON
MARY R BURKETT CUSTODIAN
1227 SIGNAL RIDGE
ROCKWALL, TX 75032

STEWART BEVERLY
1237 SIGNAL RIDGE
ROCKWALL, TX 75032

NAUMANN KURT
1238 SIGNAL RIDGE
ROCKWALL, TX 75032

TULK SHARON KAYE
1239 SIGNAL RIDGE
ROCKWALL, TX 75032

MONTOYA ASHLEY R & JOSE L
124 MISCHIEF LANE
ROCKWALL, TX 75032

NGUYEN KIM LOAN
1240 SIGNAL RIDGE PL
ROCKWALL, TX 75032

N & S PROPERTIES LLC
1241 SIGNAL RIDGE
ROCKWALL, TX 75032

COCANOUGH TODD M
1242 SIGNAL RIDGE
ROCKWALL, TX 75032

JDM RENTALS I LLC
1243 SIGNAL RIDGE
ROCKWALL, TX 75032

BUNYASAI PARIYADA
1244 SIGNAL RIDGE
ROCKWALL, TX 75032

ODOM LACEY AND JOSH
125 MISCHIEF
ROCKWALL, TX 75032

STEWART BEVERLY
125 SHEPHERDS GLEN RD
ROCKWALL, TX 75032

HEATHER WRIGHT LIVING TRUST
HEATHER WRIGHT TRUSTEE
126 MISCHIEF
ROCKWALL, TX 75032

MARTIN NAN YI
127 MICHIEF LANE
ROCKWALL, TX 75032

HALAMA STEVEN
128 MISCHIEF LN
ROCKWALL, TX 75032

MANSFIELD PHYLLIS J
129 MISCHIEF LANE
ROCKWALL, TX 75032

HARGROVE PATRICIA ANN
130 MISCHIEF LANE
ROCKWALL, TX 75032

CHURY JENNIFER LEIGH & BRIAN D
131 MISCHIEF LANE
ROCKWALL, TX 75032

BUSH VERONICA GAIL LODRIGUEZA AND
JONATHON JAMES BUSH
132 MISCHIEF LN
ROCKWALL, TX 75032

COCANOUGH TODD M
1345 RIDGE RD #310
ROCKWALL, TX 75087

HEATHER WRIGHT LIVING TRUST
HEATHER WRIGHT TRUSTEE
14 NORMAN TRL
ROCKWALL, TX 75087

LANIGAN TIFFANY LEE
143 STEVENSON DR
FATE, TX 75087

JOHNSON TIFFANY MICHELLE
148 OXFORD
HEATH, TX 75032

JOHNSON TIFFANY MICHELLE
148 OXFORD DR
HEATH, TX 75032

PARNES DROR & ALEXANDRA
15 KESTREL COURT
ROCKWALL, TX 75032

PRESTON DEWEY D & NANNETTE
1501 S LAKESHORE DR
ROCKWALL, TX 75087

THOMAS BARBARA E
1507 SIGNAL RIDGE PL
ROCKWALL, TX 75032

PATTERSON WILLIAM L JR AND DWAYLA L
REVOCABLE LIVING TRUST
1508 SIGNAL RIDGE
ROCKWALL, TX 75032

GIFFORD JIM L & PAMELA
1517 SIGNAL RIDGE
ROCKWALL, TX 75032

GARDNER DAVID L REVOCABLE LIVING TRUST
DAVID L GARDNER TRUSTEE
1518 SIGNAL RIDGE
ROCKWALL, TX 75032

YANGER MORRIS & DORIS
1519 SIGNAL RIDGE
ROCKWALL, TX 75032

DECKER SARAH E
1520 SIGNAL RIDGE PL
ROCKWALL, TX 75032

MCCLENDON JAMIE
1521 SIGNAL RIDGE PL
ROCKWALL, TX 75032

KUMAR ANVITA
1522 SIGNAL RIDGE
ROCKWALL, TX 75032

TUDOR JEAN
1523 SIGNAL RIDGE PL
ROCKWALL, TX 75032

TABOR MARILYN W
1524 SIGNAL RIDGE PL
ROCKWALL, TX 75032

LIBERTY TRUST COMPANY LTD
FBO CUSTODIANS SHERYL LYNNE COMPTON
AND WILLIAM D COMPTON
1525 SIGNAL RIDGE
ROCKWALL, TX 75032

SEVILLA ELIZABETH
1526 SIGNAL RIDGE PL
ROCKWALL, TX 75032

PALERMO JAMES ALBERT
1527 SIGNAL RIDGE
ROCKWALL, TX 75032

COLLINS KATHY
1528 SIGNAL RIDGE PL
ROCKWALL, TX 75032

PRICE MOLLIE L TRUST
MOLLIE L PRICE TRUSTEE
1529 SIGNAL RIDGE
ROCKWALL, TX 75032

AMHILL FINANCIAL LLP
1530 SIGNAL RIDGE
ROCKWALL, TX 75032

PRICE MOLLIE L TRUST
MOLLIE PRICE TRUSTEE
1531 SIGNAL RIDGE
ROCKWALL, TX 75032

SRYGLEY JAMES
1532 SIGNAL RIDGE
ROCKWALL, TX 75032

YANGER MORRIS & DORIS
1533 SIGNAL RIDGE
ROCKWALL, TX 75032

RICKERSON CHARLES AND VIRGINIA
1534 SIGNAL RIDGE
ROCKWALL, TX 75032

SCHUERENBERG CHARLES AND PENNIE
1535 SIGNAL RIDGE
ROCKWALL, TX 75032

AMHILL FINANCIAL L.P.
1536 SIGNAL RIDGE
ROCKWALL, TX 75032

LANIGAN TIFFANY LEE
1537 SIGNAL RIDGE
ROCKWALL, TX 75032

BALDWIN GLENN RAY
1538 SIGNAL RIDGE
ROCKWALL, TX 75032

SPURLOCK BRENDA CAROL
1539 SIGNAL RIDGE
ROCKWALL, TX 75032

RICKERSON CHARLES AND VIRGINIA
1540 SIGNAL RIDGE
ROCKWALL, TX 75032

GORDON NANCY ARAKAKI
159 W 118TH ST APT PH-H
NEW YORK CITY, NY 10026

MILLER LYNETTE LIFE ESTATE
ALISON LYN FOX
1601 BAYCREST TRAIL
HEATH, TX 75032

NAUMANN KURT
168 STONELEIGH DR
HEATH, TX 75032

DWA EQUITIES LLC
1802 SIGNAL RIDGE
ROCKWALL, TX 75032

COPE JEANETTE M
1804 SIGNAL RIDGE PL

GUZZI CHARLES F & MURIEL Y
18635 TULSA ST
NORTHRIDGE, CA 91326

1879 ROCKETEER HOLDINGS LLC
1879 SIGNAL RIDGE
ROCKWALL, TX 75032

OARD EUGENE E
1883 SIGNAL RIDGE
ROCKWALL, TX 75032

RUBLE ROLAND E AND BARBARA R
1887 SIGNAL RIDGE PLACE
ROCKWALL, TX 75032

MILLER LYNETTE LIFE ESTATE
ALISON LYN FOX
1891 SIGNAL RIDGE
ROCKWALL, TX 75032

SCHUERENBERG CHARLES AND PENNIE
1907 KINGS PASS
HEATH, TX 75032

BREZ RAYMOND C & M LYNNE TRUSTEES
BREZ FAMILY TRUST
1910 SIGNAL RIDGE
ROCKWALL, TX 75032

GIFFORD JIM L & PAMELA
1964 GULLWING DR
ROCKWALL, TX 75087

CHAMBERLIN PROPERTIES LLC
2005 LAKE FOREST
ROCKWALL, TX 75087

LARAPINTA LLC
2028 E. BEN WHITE BLVD # 240-5820
AUSTIN, TX 75741

RICKERSON CHARLES AND VIRGINIA
206 LAKEHILL DRIVE
ROCKWALL, TX 75087

RICKERSON CHARLES AND VIRGINIA
206 LAKEHILL DRIVE
ROCKWALL, TX 75087

HOGAN JERRY
2109 TWILIGHT PT
HEATH, TX 75032

MOORE GREGORY J
2140 PORTOFINO DR
ROCKWALL, TX 75032

BALDWIN GLENN RAY
216 STANFORD CT
HEATH, TX 75032

1879 ROCKETEER HOLDINGS LLC
2200 ROSS AVE 3600
DALLAS, TX 75201

ODOM LACEY AND JOSH
2402 YACHT CLUB DR
ROCKWALL, TX 75032

THOMAS VELIA
2612 GULL LAKE DRIVE
PLANO, TX 75025

HANSEN J D & PATRICIA
262 VICTORY LN
ROCKWALL, TX 75032

CSH 2016-2 BORROWER LLC
264 VICTORY
ROCKWALL, TX 75032

DILOV VANIO
2717 LAKEWOOD DR
ROWLETT, TX 75088

BURKETT BENJAMIN HERRINGTON E
MARY R BURKETT CUSTODIAN
277 TERRY LANE
HEATH, TX 75032

SEEDS DAVID R
2961 S CHERRY WAY
DENVER, CO 80222

BEVILL HELEN M AND
CHANDRA KARLEN
2977 OAK DR
ROCKWALL, TX 75032

LIBERTY TRUST COMPANY LTD
CUSTODIAN FBO WILLIAM COMPTON
2984 HUNTERGLEN ROAD
ROCKWALL, TX 75032

PERRY GEORGE DAVID & SANDRA SUE
299 VICTORY LN
ROCKWALL, TX 75032

HAIL CHRIS & MELODY
3 WILTSHIRE COURT
HEATH, TX 75032

MCMURTRE DREW
3000 TWIN LAKES DR
PROSPER, TX 75078

ALLEN ANN
301 VALIANT
ROCKWALL, TX 75032

WARD ANDREA N
303 VALIANT DRIVE
ROCKWALL, TX 75032

DEAL ROBERT
305 VALIANT DRIVE
ROCKWALL, TX 75032

MCMINN KIMBERLY
306 VICTORY
ROCKWALL, TX 75032

AMH 2014-2 BORROWER LLC
30601 AGOURA RD SUITE 200
AGOURA HILLS, CA 91301

MCNAIR KELLY
307 VICTORY LN
ROCKWALL, TX 75032

AMH 2014-2 BORROWER LLC
310 VICTORY
ROCKWALL, TX 75032

HAMMAN CHRISTOPHER & ANNE MARIE
MARTIN
314 VALIANT DRIVE
ROCKWALL, TX 75032

MAY DEBRA AND RODNEY
314 VICTORY LN
ROCKWALL, TX 75032

LOREDO SARAHI
315 VICTORY LN
ROCKWALL, TX 75032

MURPHY CASEY D AND BRIANNA
318 VALIANT DRIVE
ROCKWALL, TX 75032

SRP SUB LLC
320 VALIANT
ROCKWALL, TX 75032

DUNAWAY TINA
322 VALIANT DRIVE
ROCKWALL, TX 75032

JOHNSON TIFFANY MICHELLE
326 VALIANT
ROCKWALL, TX 75032

LIECHTY SHIRLEY JEAN
C/O MRS AMY JENSEN
331 MOCKINGBIRD LN
AUBURN, AL 36830

HARMON H VICTOR
337 VALIANT
ROCKWALL, TX 75032

N & S PROPERTIES LLC
3402 ANTHONY CIR
ROWLETT, TX 75088

BUNYASAI PARIYADA
3416 CAMPUS AVE
CLAREMONT, CA 91711

FALLS DAVID & TERRI
3608 LAKESIDE DR
ROCKWALL, TX 75087

TULK SHARON KAYE
408 COLUMBIA DR
ROCKWALL, TX 75032

PALERMO JAMES ALBERT
411 DRIFTWOOD ST
ROCKWALL, TX 75087

YANGER MORRIS & DORIS
427 COLUMBIA DR
ROCKWALL, TX 75032

RUBENSTEIN ALAN J AND
GINA L STRICKLIN
4501 YACHT CLUB DR
ROCKWALL, TX 75032

KUMAR ANVITA
4701 COPPER MOUNTAIN LANE
RICHARDSON, TX 75082

SELZER DEANNA
510 TURTLE COVE BLVD STE 109
ROCKWALL, TX 75087

HARMON H VICTOR
519 E INTERSTATE 30 PMB 212
ROCKWALL, TX 75087

MARSHALL SAMUEL AND DIANA
5502 CHALLENGER CT
ROCKWALL, TX 75032

LINLEY ZACHARY AND ELIZABETH HOLLAND-
5504 AUSTRALIA COURT
ROCKWALL, TX 75032

MCKAY ADRIAN AND ROBERTA
5504 CHALLENGER CT
ROCKWALL, TX 75032

WILSON STEPHEN L & JANPRAPHA T
5506 AUSTRALIA CT
ROCKWALL, TX 75032

KJT FLYING PROPERTIES LLC
5506 CHALLENGER
ROCKWALL, TX 75032

YOUNG SHERRY WHITE
5508 AUSTRALIA CT
ROCKWALL, TX 75032

NORTON ANGELA
5508 CHALLENGER CT
ROCKWALL, TX 75032

HOWERTON JASON BRUCE & BRITTANY JEAN
WILSON
5510 AUSTRALIA COURT
ROCKWALL, TX 75032

EVERSWICK LIVING TRUST
DAVID N AND JOYCE EVERSWICK TRUSTEES
5510 CHALLENGER
ROCKWALL, TX 75032

TAYLOR JOE & CINDY
5511 AUSTRALIA CT
ROCKWALL, TX 75032

BEST JAMES AND DEBRA
5512 CHALLENGER CT
ROCKWALL, TX 75032

STARBIRD RYAN D AND LAUREN
5514 CHALLENGER CT
ROCKWALL, TX 75032

CABANISS CHAR CHERICE
DAVID R DE LA CERDA
5516 CHALLENGER CT
ROCKWALL, TX 75032

FREDERIKSEN JOHN C & ARLENE C REV LIV TR
JOHN C & ARLENE C FREDERIKSEN TRUSTEES
5518 CHALLENGER CT
ROCKWALL, TX 75032

FREDERIKSEN JOHN C & ARLENE C REV LIV TR
JOHN C & ARLENE C FREDERIKSEN TRUSTEES
5520 CHALLENGER
ROCKWALL, TX 75032

HENRY MARY DELINA & DOUGLAS GARFIELD
5522 CHALLENGER COURT
ROCKWALL, TX 75032

CONFIDENTIAL
5526 CHALLENGER COURT
ROCKWALL, TX 75032

SHELTON ROBERT M
5528 CHALLENGER CT
ROCKWALL, TX 75032

WATKINS JAMES & ELLEN
5530 CHALLENGER CT
ROCKWALL, TX 75032

EVERSWICK LIVING TRUST
DAVID N AND JOYCE EVERSWICK TRUSTEES
56 JOYCE DR
SUCCASUNNA, NJ 7876

ALLEN ANN
5612 CAMBRIA DR
ROCKWALL, TX 75032

ALVARADO KRESHA
5905 VOLUNTEER PL
ROCKWALL, TX 75032

DWYER AMY SUZANNE
6101 VOLUNTEER PL
ROCKWALL, TX 75032

OARD EUGENE E
6104 BLACK SWAN CIR
GARLAND, TX 75044

HARRIS SUSAN
724 WINDSONG LN
ROCKWALL, TX 75032

COPE JEANETTE M
7685 STATE HIGHWAY 53 N
UPPER SANDUSKY, OH 43351

PATTERSON WILLIAM L JR AND DWAYLA L
REVOCABLE LIVING TRUST
782 HANOVER DR
ROCKWALL, TX 75087

ARMSTRONG JOHN D III AND INDIVIDUAL
804 EAGLE PASS
HEATH, TX 75032

CROW BILL CHARLES & RUTH ELIZABETH
828 CR 1035
COOPER, TX 75432

CSH 2016-2 BORROWER LLC
8665 EAST HARTFORD DR SUITE 200
SCOTTSDALE, AZ 85255

SRP SUB LLC
8665 EAST HARTFORD DRIVE SUITE 200
SCOTTSDALE, AZ 85255

LIECHTY SHIRLEY JEAN
C/O MRS AMY JENSEN
921 SIGNAL RIDGEPL
ROCKWALL, TX 75032

PRICE MOLLIE L TRUST
MOLLIE L PRICE TRUSTEE
C/O CHARLES LINEVILLE P O BOX 743612
DALLAS, TX 75374

AMHILL FINANCIAL LP
P. O. BOX 1179
ROCKWALL, TX 75087

PAIGE RYAN PROPERTIES LLC
P. O. BOX 853
WYLIE, TX 75098

MCMINN KIMBERLY
PMB 239 11654 PLAZA AMERICA DR
RESTON, VA 20190

RICHMOND JANET M & TOM R
PO BOX 1145
ROCKWALL, TX 75087

AMHILL FINANCIAL LP
ATTN JIM PETERS
PO BOX 1179
ROCKWALL, TX 75087

KJT FLYING PROPERTIES LLC
PO BOX 1476
ROCKWALL, TX 75087

SRYGLEY JAMES
PO BOX 1928
ROCKWALL, TX 75087

JDM RENTALS I LLC
PO BOX 2110
ROCKWALL, TX 75087

MARICH ENTERPRISE CORPORATION
PO BOX 2319
ROCKWALL, TX 75087

CHANDLERS LANDING COMMUNITY ASSOC
PO BOX 638
ROCKWALL, TX 75087

PRICE MOLLIE L TRUST
MOLLIE PRICE TRUSTEE
PO BOX 743612
DALLAS, TX 75374

RUSH MAJOR
PO BOX 760794
GARLAND, TX 75046

HIGGINS MICHAEL R AND ANN S
PO BOX 850225
MESQUITE, TX 75185

ROCKWALL, TX 75032