

Z2018-027 - LADERA ROCKWALL ZONING - LOCATION MAP =



City of Rockwall

Planning & Zoning Department
 385 S. Goliad Street
 Rockwall, Texas 75032
 (P): (972) 771-7745
 (W): www.rockwall.com

The City of Rockwall GIS maps are continually under development and therefore subject to change without notice. While we endeavor to provide timely and accurate information, we make no guarantees. The City of Rockwall makes no warranty, express or implied, including warranties of merchantability and fitness for a particular purpose. Use of the information is the sole responsibility of the user.







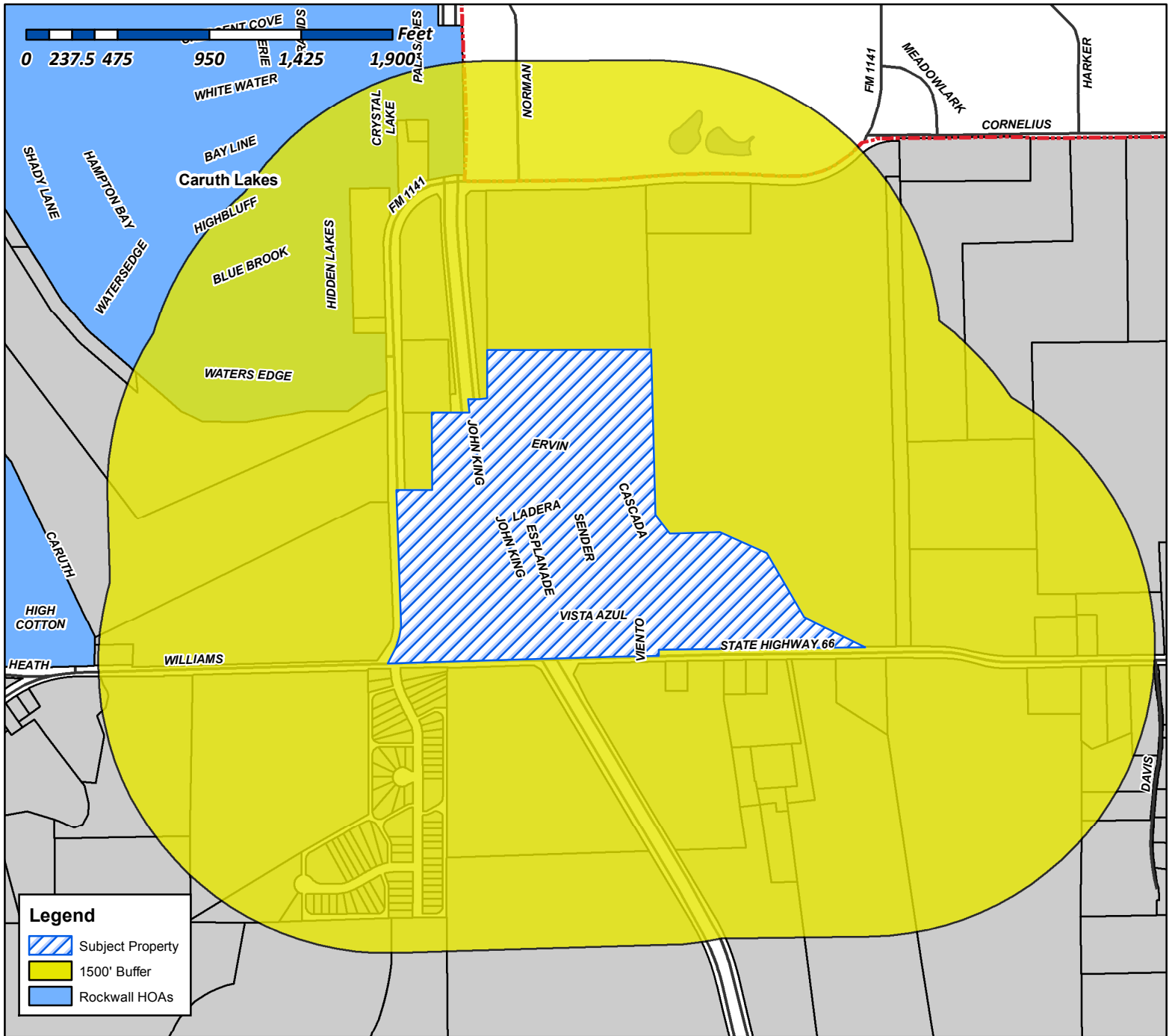

City of Rockwall

Planning & Zoning Department
385 S. Goliad Street
Rockwall, Texas 75087
(P): (972) 771-7745
(W): www.rockwall.com

The City of Rockwall GIS maps are continually under development and therefore subject to change without notice. While we endeavor to provide timely and accurate information, we make no guarantees. The City of Rockwall makes no warranty, express or implied, including warranties of merchantability and fitness for a particular purpose. Use of the information is the sole responsibility of the user.



Legend

-  Subject Property
-  1500' Buffer
-  Rockwall HOAs

Case Number: Z2018-027
Case Name: Ladera Rockwall
Case Type: Zoning
Zoning: Amendmend to PD-85
Case Address: NE Corner of John King/SH 66

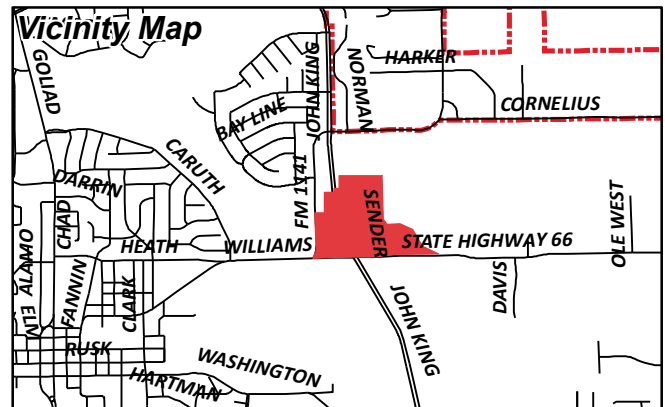

Date Created: 6/19/2018
 For Questions on this Case Call (972) 771-7745



City of Rockwall

Planning & Zoning Department
385 S. Goliad Street
Rockwall, Texas 75087
(P): (972) 771-7745
(W): www.rockwall.com

The City of Rockwall GIS maps are continually under development and therefore subject to change without notice. While we endeavor to provide timely and accurate information, we make no guarantees. The City of Rockwall makes no warranty, express or implied, including warranties of merchantability and fitness for a particular purpose. Use of the information is the sole responsibility of the user.

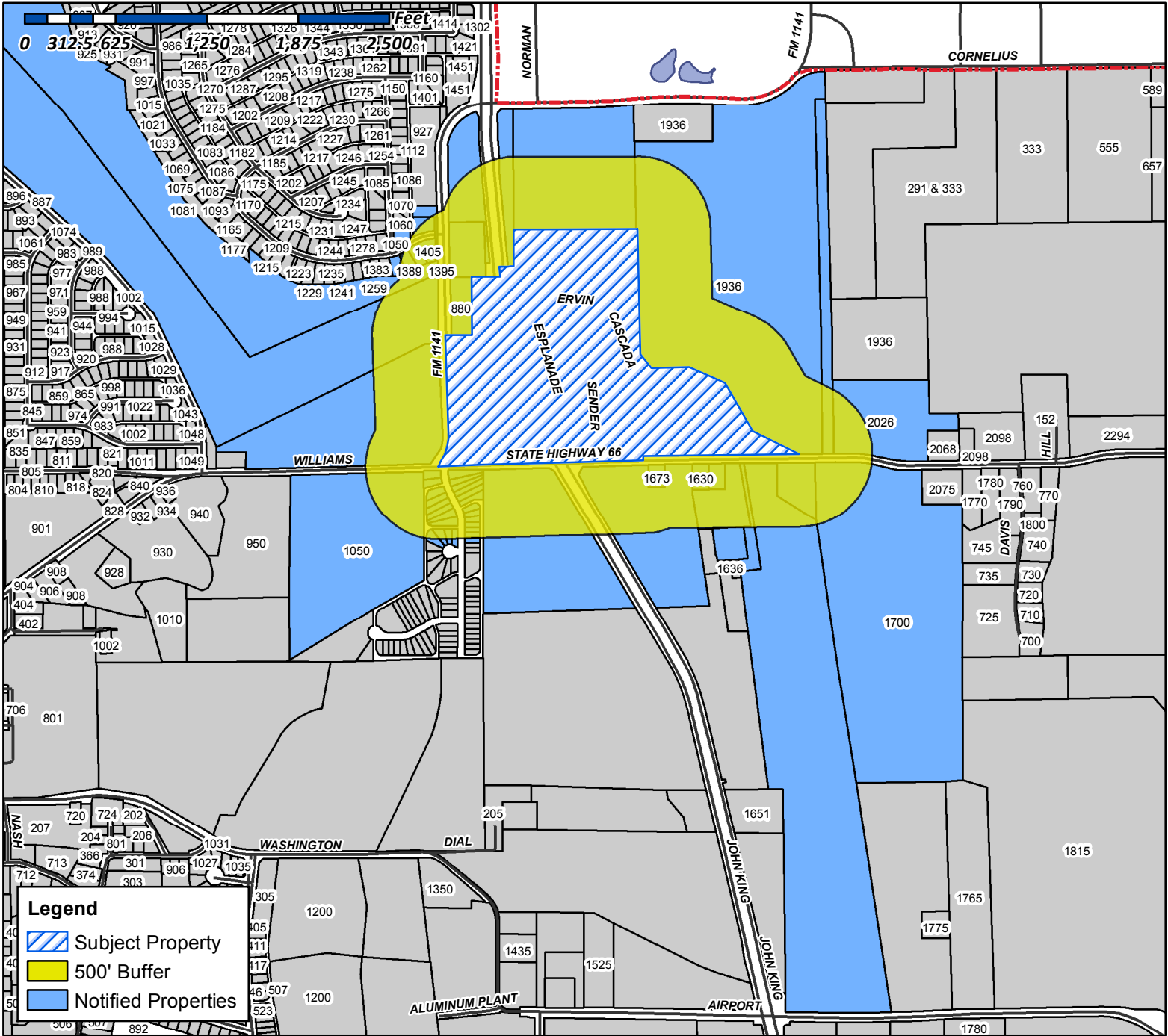

Case Number: Z2018-027
Case Name: Ladera Rockwall
Case Type: Zoning
Zoning: Amendmend to PD-85
Case Address: NE Corner of John King/SH 66

Date Created: 06/15/2018
For Questions on this Case Call (972) 771-7745

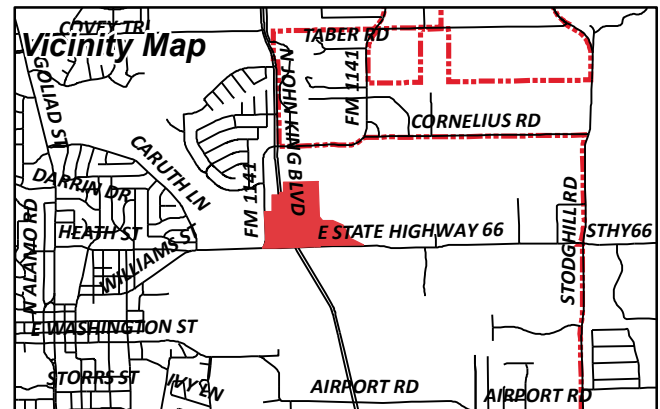

CURRENT RESIDENT
1050 WILLIAMS
ROCKWALL, TX 75087

KEHM NATALIE & DONAVON
1050 HIDDEN LAKES WAY
ROCKWALL, TX 75087

SEE BETTY
110 WESTMINISTER
ROCKWALL, TX 75032

RYDER HEATH JAMES AND MELANIE ANN
1383 WATER EDGE DRIVE
ROCKWALL, TX 75087

WIGLE NICHOLAS & AMANDA N
1389 WATERS EDGE DRIVE
ROCKWALL, TX 75087

ELLIOTT CHRISTOPHER ANDREW & HEATHER R
1395 WATERS EDGE DRIVE
ROCKWALL, TX 75087

HANNAH ANGELIA YVETTE
1405 WATERS EDGE DRIVE
ROCKWALL, TX 75087

CURRENT RESIDENT
1630 WILLIAMS
ROCKWALL, TX 75087

CURRENT RESIDENT
1673 HWY66
ROCKWALL, TX 75087

PEOPLES MICHAEL L JR AND
0
1700 STATE HIGHWAY 66
ROCKWALL, TX 75087

CURRENT RESIDENT
1936 HWY 66
ROCKWALL, TX 75087

CURRENT RESIDENT
2026 HWY 66
ROCKWALL, TX 75087

ROCKWALL PROPERTY CORP
0
305 PARK PLACE BLVD
ROCKWALL, TX 75087

RWLADERA LLC
361 W BYRON NELSON BLVD 0
ROANOKE, TX 76262

DAVIS WILLIAM PAUL JR
510 TURTLE COVE BLVD 0
ROCKWALL, TX 75087

CARUTH RIDGE ESTATES HOMEOWNERS
ASSOCIATION INC
0
5757 ALPHA RD STE 680
DALLAS, TX 75240

CURRENT RESIDENT
880 FM1141
ROCKWALL, TX 75087

PEOPLES BILLY W
PO BOX 35
ROCKWALL, TX 75087

WHITTLE ROBERT S
PO BOX 369
ROCKWALL, TX 75087

PEOPLES MICHAEL L
PO BOX 41
ROCKWALL, TX 75087

**CURRENT FUTURE LAND USE MAP DESIGNATION:
COMMERCIAL, HIGH DENSITY RESIDENTIAL,
& LOW DENSITY RESIDENTIAL**

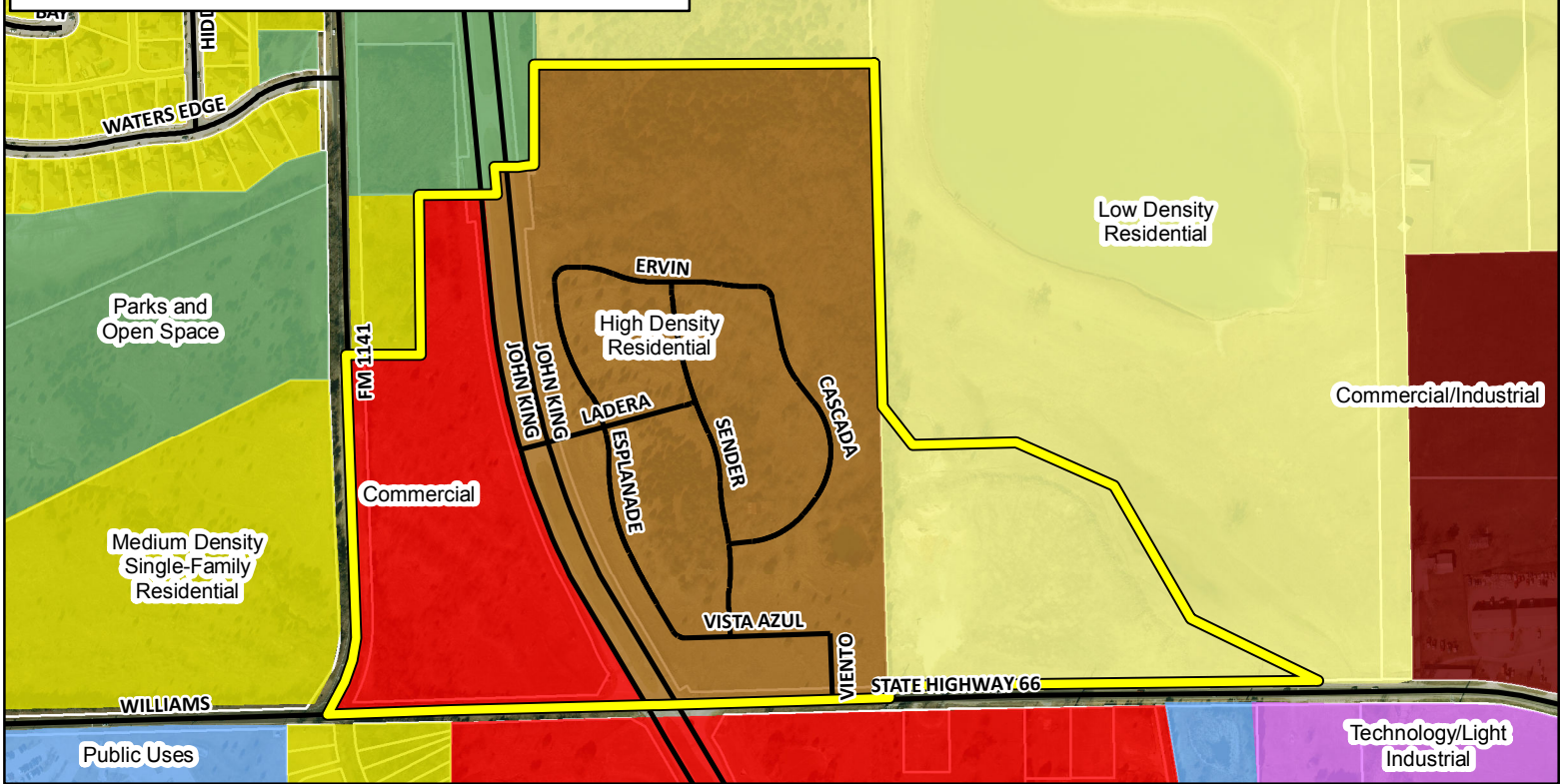
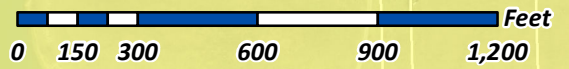

**PROPOSED FUTURE LAND USE MAP DESIGNATION:
COMMERCIAL & HIGH DENSITY RESIDENTIAL**

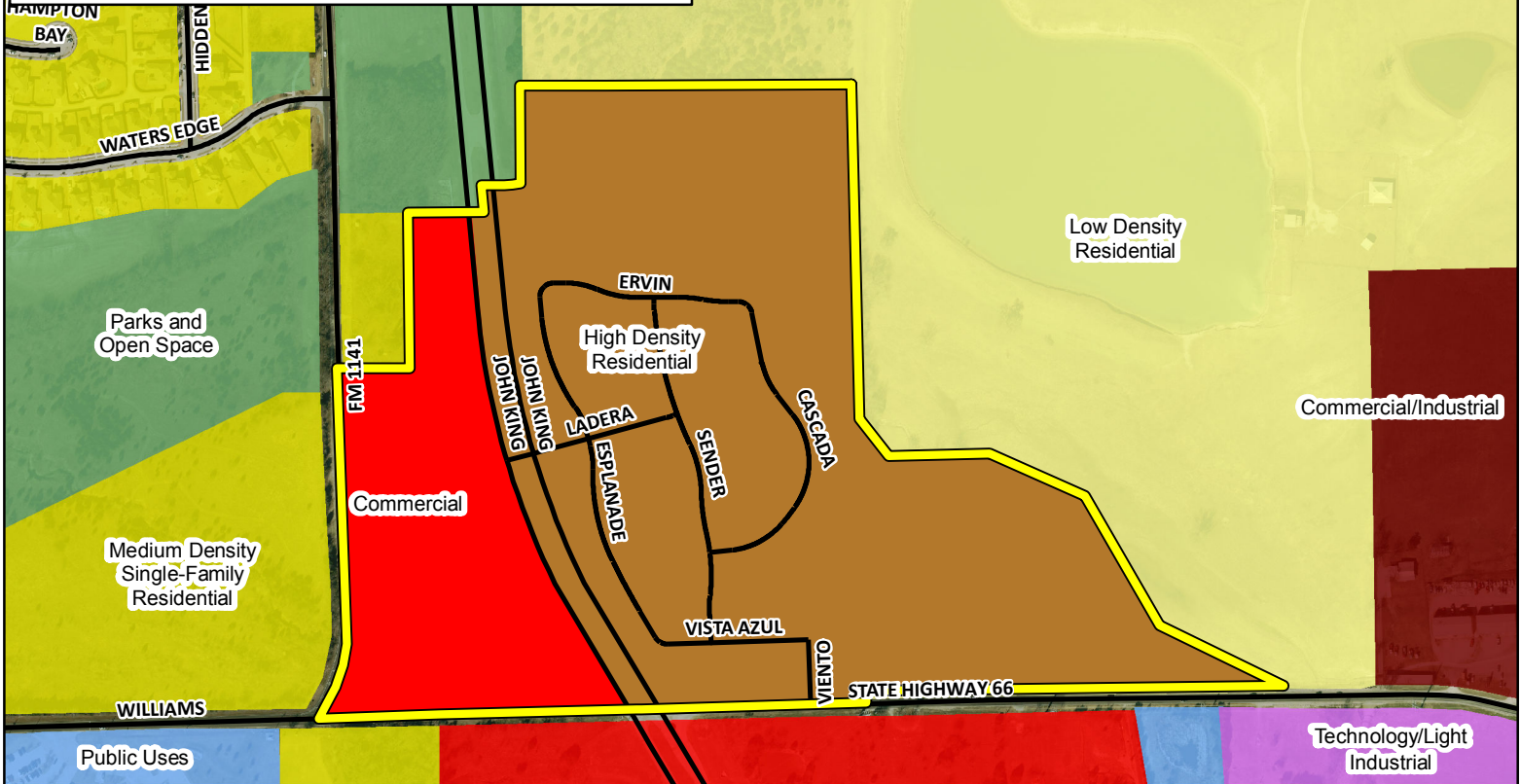
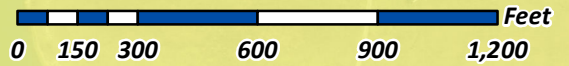

City of Rockwall

Planning & Zoning Department
385 S. Goliad Street
Rockwall, Texas 75032
(P): (972) 771-7745
(W): www.rockwall.com

The City of Rockwall GIS maps are continually under development and therefore subject to change without notice. While we endeavor to provide timely and accurate information, we make no guarantees. The City of Rockwall makes no warranty, express or implied, including warranties of merchantability and fitness for a particular purpose. Use of the information is the sole responsibility of the user.





SITE PLANNING CIVIL ENGINEERING PLATTING
CONSULTANTS, LLC
LAND SURVEYING LANDSCAPE ARCHITECTURE

TBPE Firm No. 1798

TBPLS Firm No. 10047700

June 15, 2018

Mr. Ryan Miller
Director of Planning
City of Rockwall
385 S. Goliad Street
Rockwall, Texas 75087

RE: Ladera Rockwall – Zoning PD Amendment to add 9 Acres
Letter of Intent
G&A Job Number: 18193

Mr. Miller,

Please accept this letter, on behalf of Integrity Group, as an explanation of the proposed application. We are submitting a Zoning Change Request application to amend the existing Ladera Planned Development Ordinance (Ord. No. 17-55) in order to add nine acres of land on the east side of the development.

The Ladera PD Ordinance was adopted on October 16, 2017. The additional nine acres will allow for 36 more units to be included into the Ladera community. This property is located along Highway 66, directly the east and contiguous to the original Ladera property. The overall acreage of Ladera will increase from 28 acres to 37 acres.

We are looking forward to enlarging this development to provide for more opportunities for future residents of Ladera and Rockwall. Please do not hesitate to contact me if you have any questions regarding this project and the presented requests.

Sincerely,

A handwritten signature in blue ink that reads "Randi L. Rivera".

Randi L. Rivera, AICP

cc. Mr. John Delin, Integrity Group, LLC
Mr. Robert J. Dollak, Jr., P.E., G&A Consultants, LLC

CITY OF ROCKWALL

ORDINANCE NO. 17-XX

AN ORDINANCE OF THE CITY COUNCIL OF THE CITY OF ROCKWALL, TEXAS, AMENDING PLANNED DEVELOPMENT DISTRICT 85 (PD-85) [ORDINANCE NO. 17-55] AND THE UNIFIED DEVELOPMENT CODE [ORDINANCE NO. 04-38] OF THE CITY OF ROCKWALL, AS HERETOFORE AMENDED, SO AS TO INCORPORATE A 9.762-ACRE TRACT OF LAND ZONED AGRICULTURAL (AG) DISTRICT INTO PLANNED DEVELOPMENT DISTRICT 85 (PD-85) CREATING A 47.694-ACRE PLANNED DEVELOPMENT DISTRICT IDENTIFIED AS TRACTS 4-01 & 5 OF THE M. B. JONES SURVEY, ABSTRACT NO. 122, CITY OF ROCKWALL, ROCKWALL COUNTY, TEXAS AND MORE FULLY DESCRIBED HEREIN BY EXHIBIT 'A'; PROVIDING FOR SPECIAL CONDITIONS; PROVIDING FOR A PENALTY OF FINE NOT TO EXCEED THE SUM OF TWO THOUSAND DOLLARS (\$2,000.00) FOR EACH OFFENSE; PROVIDING FOR A SEVERABILITY CLAUSE; PROVIDING FOR A REPEALER CLAUSE; PROVIDING FOR AN EFFECTIVE DATE.

WHEREAS, the City has received a request by the John Delin of Integrity Group, LLC for the approval of a zoning change amending Planned Development District 85 (PD-85) [Ordinance No. 17-55] for the purpose of incorporating a 9.762-acre tract of land zoned Agricultural (AG) District into Planned Development District (PD-85), allowing limited General Retail (GR) District and Single Family 7 (SF-7) District land uses on a 47.694-acre tract of land identified as Tract 4-01 & 5 of the M. B. Jones Survey, Abstract No. 122, City of Rockwall, Rockwall County, Texas and more fully described in *Exhibit 'A'* of this ordinance, which hereinafter shall be referred to as the *Subject Property* and incorporated by reference herein; and

WHEREAS, the Planning and Zoning Commission of the City of Rockwall and the governing body of the City of Rockwall in compliance with the laws of the State of Texas and the ordinances of the City of Rockwall have given the requisite notices by publication and otherwise, and have held public hearings and afforded a full and fair hearing to all property owners generally and to all persons interested in and situated in the affected area, and in the vicinity thereof, and the governing body in the exercise of its legislative discretion, has concluded that Planned Development District 85 (PD-85) [Ordinance No. 17-55] and the Unified Development Code [Ordinance No. 04-38] should be amended as follows:

NOW, THEREFORE, BE IT ORDAINED BY THE CITY COUNCIL OF THE CITY OF ROCKWALL, TEXAS:

SECTION 1. That the approval of this ordinance shall superseded all requirements stipulated in *Ordinance No. 17-55*; and,

SECTION 2. That the *Subject Property* shall be used only in the manner and for the purposes authorized by this Planned Development District Ordinance and the Unified Development Code [Ordinance No. 04-38] of the City of Rockwall as heretofore amended, as amended herein by granting this zoning change, and as maybe amended in the future;

SECTION 3. That development of the *Subject Property* shall be in accordance with the *Planned Development Concept Plans*, contained in *Exhibit 'B'* of this ordinance, attached hereto and incorporated herein by reference as *Exhibit 'B'*, which is deemed hereby to be a condition of approval of the amended zoning classification for the *Subject Property*;

SECTION 4. That development of the *Subject Property* shall be in accordance with the *Development Standards*, described in *Exhibit 'C'* of this ordinance, attached hereto and incorporated herein by reference as *Exhibit 'C'*, which is deemed hereby to be a condition of approval of the amended zoning classification for the *Subject Property*;

SECTION 5. That development of *Tract 1* of the *Subject Property* -- as described in *Exhibit 'A'* and depicted in *Exhibit 'B'* of this ordinance -- shall be in conformance with the schedule listed below (except as set forth below with regard to simultaneous processing and approvals).

- (a) The procedures set forth in the City's subdivision regulations on the date this ordinance is approved by the City, as amended by this ordinance (*including Subsections 5(b) through 5(f) below*), shall be the exclusive procedures applicable to the subdivision and platting of *Area 3* as depicted in *Exhibit 'B'* of this ordinance.
- (b) The following plans and plats shall be required in the order listed below (*except as set forth below with regard to simultaneous processing and approvals*). The City Council shall act on an application for an *Open Space Master Plan* in accordance with the time period specified in *Section 212.009* of the *Texas Local Government Code*.
 - (1) Open Space Master Plan
 - (2) Master Plat
 - (3) Preliminary Plat
 - (4) PD Site Plan
 - (5) Final Plat
- (c) *Open Space Master Plan*. An *Open Space Master Plan* for the *Subject Property* as depicted in *Exhibit 'B'* of this ordinance, prepared in accordance with this ordinance, and shall be considered for approval by the City Council following recommendation of the Parks and Recreation Board.
- (d) *Master Plat*. A *Master Plat* for the *Subject Property* as depicted in *Exhibit 'B'* of this ordinance shall be submitted and shall identify the proposed timing of each phase of the proposed development. A *Master Plat* application may be processed by the City concurrently with an *Open Space Master Plan* for the development.
- (e) *Preliminary Plat*. A *Preliminary Plat* covering all of the *Subject Property* as depicted in *Exhibit 'B'* of this ordinance shall be submitted and shall include a *Treescape Plan*. A *Preliminary Plat Application* may be processed by the City concurrently with a *Master Plat* and an *Open Space Master Plan Application* for the development.
- (f) *PD Site Plan*. A *PD Site Plan* covering all of the *Subject Property* as depicted in *Exhibit 'B'* of this ordinance shall be submitted and shall identify all site/landscape/hardscape plan(s) for all open space, neighborhood parks, trail systems, street buffers and entry features. A *PD Site Plan* application may be processed by the City concurrently with a *Final Plat Application* for the development.
- (g) *Final Plat*. Prior to the issuance of any building permits, a *Final Plat*, conforming to the *Preliminary Plat*, for all of the *Subject Property* as depicted in *Exhibit 'B'* of this ordinance shall be submitted for approval.

SECTION 6. That any person, firm, or corporation violating any of the provisions of this ordinance shall be deemed guilty of a misdemeanor and upon conviction shall be punished by a penalty of fine not to exceed the sum of *Two Thousand Dollars* (\$2,000.00) for each offense and each and every day such offense shall continue shall be deemed to constitute a separate offense;

SECTION 7. That if any section, paragraph, or provision of this ordinance or the application of that section, paragraph, or provision to any person, firm, corporation or situation is for any reason judged invalid, the adjudication shall not affect any other section, paragraph, or provision of this ordinance or the application of any other section, paragraph or provision to any other person, firm, corporation or situation, nor shall adjudication affect any other section, paragraph, or provision of the Unified Development Code, and the City Council declares that it would have adopted the valid portions and applications of the ordinance without the invalid parts and to this end the provisions for this ordinance are declared to be severable;

SECTION 8. The standards in this ordinance shall control in the event of a conflict between this ordinance and any provision of the Unified Development Code or any provision of the City Code, ordinance, resolution, rule, regulation, or procedure that provides a specific standard that is different from and inconsistent with this ordinance. References to zoning district regulations or other standards in the Unified Development Code (including references to the *Unified Development Code*), and references to overlay districts, in this ordinance or any of the Exhibits hereto are those in effect on the date this ordinance was passed and approved by the City Council of the City of Rockwall, Texas;

SECTION 9. That this ordinance shall take effect immediately from and after its passage and the publication of the caption of said ordinance as the law in such cases provides;

PASSED AND APPROVED BY THE CITY COUNCIL OF THE CITY OF ROCKWALL, TEXAS, THIS THE 6TH DAY OF AUGUST, 2018.

Jim Pruitt, *Mayor*

ATTEST:

Kristy Cole, *City Secretary*

APPROVED AS TO FORM:

Frank J. Garza, *City Attorney*

1st Reading: July 16, 2018

2nd Reading: August 6, 2018

Exhibit 'A':
Legal Description

Legal Description for Tract 1:

Tract 1 9.894 acres M. B. Jones Survey, Abstract No. 122 B. Jones Survey, Abstract No. 122 City of Rockwall Rockwall County, Texas

BEING all that certain lot, tract or parcel of land situated in the M. B. Jones Survey, Abstract No. 122, City of Rockwall, Rockwall County, Texas, and being a portion of a called 41.921 acre tract of land described as Tract 3, in deed to John H. Cullins, recorded in Instrument No. 2008-00396743, Deed Records, Rockwall County, Texas, and being more particularly described as follows:

BEGINNING at a 1/2 inch rebar set with cap stamped "G&A CONSULTANTS", being in the north line of U. G&A CONSULTANTS", being in the north line of U. S. Highway 66, from which a 1/2 inch rebar found at the southeast corner of said 41.921 acres bears N 88°18'19" E, a distance 724.55 feet; E, a distance 724.55 feet;

THENCE S 88°18'19" W, with the north line of U. S. Highway 66, a distance of 553.89 feet to a wooden W, with the north line of U. S. Highway 66, a distance of 553.89 feet to a wooden right-of-way monument found at the southwest corner of said 41.921 acre tract, and being in the east line of F. M. 1141;

THENCE N 02°39'30" W, with the east line of F. M. 1141, a distance of 601.94 to a 1/2 inch rebar W, with the east line of F. M. 1141, a distance of 601.94 to a 1/2 inch rebar found;

THENCE N 01°20'56" W, continuing with the east line of F. M. 1141, a distance of 314.19 feet to a 1/2 W, continuing with the east line of F. M. 1141, a distance of 314.19 feet to a 1/2 inch rebar set with cap stamped "G&A CONSULTANTS", being the southwest corner of a called 1.837 G&A CONSULTANTS", being the southwest corner of a called 1.837 , being the southwest corner of a called 1.837 acre tract of land described as Tract 1 in deed to Betty Bogard, recorded in Instrument No. 2008-00396742, Deed Records, Denton County, Texas;

THENCE N 89°26'01" E, with the south line of said 1.837 acre tract, a distance of 200.01 feet to a 1/2 E, with the south line of said 1.837 acre tract, a distance of 200.01 feet to a 1/2 inch rebar set with cap stamped "G&A CONSULTANTS", being the southeast corner thereof, and being at G&A CONSULTANTS", being the southeast corner thereof, and being at , being the southeast corner thereof, and being at an inner ell corner of said 41.921 acre tract;

THENCE N 01°20'56" W, with the east line of said 1.837 acre tract, a distance of 400.02 feet to a 1/2 W, with the east line of said 1.837 acre tract, a distance of 400.02 feet to a 1/2 inch rebar set with cap stamped "G&A CONSULTANTS", being in the south line of a 10.942 acre tract of G&A CONSULTANTS", being in the south line of a 10.942 acre tract of , being in the south line of a 10.942 acre tract of land described in deed to City of Rockwall, recorded in Instrument No. 2007-00389123, Deed Records, Rockwall County, Texas;

THENCE N 89°26'01" E, with the south line of said 10.942 acre tract, a distance of 65.39 feet to a 1/2 E, with the south line of said 10.942 acre tract, a distance of 65.39 feet to a 1/2 inch rebar set with cap stamped "G&A CONSULTANTS", being the most northwesterly corner of a called G&A CONSULTANTS", being the most northwesterly corner of a called , being the most northwesterly corner of a called 3.989 acre tract of land being titled as "Highway 205 Bypass R.O.W." in City of Rockwall vs. John Cullins

Highway 205 Bypass R.O.W." in City of Rockwall vs. John Cullins in City of Rockwall vs. John Cullins and Burks T. Payne, Jr., Cause No. 180-633, recorded in Instrument No. 2009-00410863, Deed Records, Rockwall County, Texas, also known as John King Boulevard;

THENCE Southeasterly with the west line of said 3.989 acre tract and John King Boulevard, the following eight (8) calls:

S 05°14'42" E, a distance of 119.42 feet to a 1/2 inch rebar set with cap stamped "G&A E, a

Exhibit 'A':
Legal Description

distance of 119.42 feet to a 1/2 inch rebar set with cap stamped "G&A G&A CONSULTANTS";

N 84°45'18" E, a distance of 20.00 feet to a 1/2 inch rebar set with cap stamped "G&A E, a distance of 20.00 feet to a 1/2 inch rebar set with cap stamped "G&A G&A CONSULTANTS";

S 05°14'42" E, a distance of 189.30 feet to a 1/2 inch rebar set with cap stamped "G&A E, a distance of 189.30 feet to a 1/2 inch rebar set with cap stamped "G&A G&A CONSULTANTS";

Southeasterly with a curve to the left having a radius of 2060.00 feet, a central angle of 23°19'48", and , and an arc length of 838.80 feet, whose chord bears S 16°54'36" E, a distance of 833.02 feet to a 1/2 E, a distance of 833.02 feet to a 1/2 inch rebar set with cap stamped "G&A CONSULTANTS"; G&A CONSULTANTS";

Southeasterly with a curve to the right having a radius of 586.00 feet, a central angle of 07°34'10", and an arc length of 77.42 feet, whose chord bears S 24°47'26" E, a distance of 77.36 feet to a 1/2 E, a distance of 77.36 feet to a 1/2 inch rebar set with cap stamped "G&A CONSULTANTS"; G&A CONSULTANTS";

Southeasterly with a curve to the left having a radius of 314.00 feet, a central angle of 09°39'36", and , and an arc length of 52.94 feet, whose chord bears S 25°50'09" E, a distance of 52.88 feet to a 1/2 inch E, a distance of 52.88 feet to a 1/2 inch rebar set with cap stamped "G&A CONSULTANTS"; G&A CONSULTANTS";

S 30°39'57" E, a distance of 32.25 feet to a 1/2 inch rebar set with cap stamped "G&A E, a distance of 32.25 feet to a 1/2 inch rebar set with cap stamped "G&A G&A CONSULTANTS";

S 28°49'11" W, a distance of 32.25 feet to the *POINT OF BEGINNING* and containing approximately 9.894 acres of land.

Exhibit 'A':
Legal Description

Legal Description for Tract 2:

BEING all that certain lot, tract or parcel of land situated in the M. B. Jones Survey, Abstract No. 122, City of Rockwall, Rockwall County, Texas, and being a portion of a called 41.921 acre tract of land described as Tract 3, in deed to John H. Cullins, recorded in Instrument No. 2008-00396743, Deed Records, Rockwall County, Texas, and being part of a called 73.2744 acre tract of land described in deed to Mike L. People, recorded in Volume 850, Page 15, Deed Records, Rockwall County, Texas, and being more particularly described as follows:

BEGINNING at a 1/2 inch rebar found at the southeast corner of said 41.921 acre tract, and the southwest corner of said 73.2744 acre tract and being in the north line of U. S. Highway 66;

THENCE S 88°18'19"W, with the north line of U. S. Highway 66, a distance of 490.46 feet to a 1/2 inch rebar set with cap stamped "G&A CONSULTANTS", being the most southeasterly corner of a called 3.989 acre tract of land being titled as "Highway 205 Bypass R.O.W." in City of Rockwall vs. John Cullins and Burks T. Payne, Jr., Cause No. 180-633, recorded in Instrument No. 2009-00410863, Deed Records, Rockwall County, Texas, also known as John King Boulevard;

THENCE Northwesterly with the east line of said 3.989 acre tract and John King Boulevard, the following seven (7) calls:

N 30°39'57" W, a distance of 19.44 feet to a 1/2 inch rebar set with cap stamped "G&A CONSULTANTS";

S 59°20'03" W, a distance of 21.30 feet to a 1/2 inch rebar set with cap stamped "G&A CONSULTANTS";

N 30°39'57" W, a distance of 211.63 feet to a 1/2 inch rebar set with cap stamped "G&A CONSULTANTS";

Northwesterly with a curve to the right having a radius of 1940.00 feet, a central angle of 25°25'15", and an arc length of 860.73 feet, whose chord bears N 17°57'20" W, a distance of 853.69 feet to a 1/2 inch rebar set with cap stamped "G&A CONSULTANTS";

N 05°14'42" W, a distance of 158.73 feet to a 1/2 inch rebar set with cap stamped "G&A CONSULTANTS";

N 84°45'18" E, a distance of 20.00 feet to a 1/2 inch rebar set with cap stamped "G&A CONSULTANTS";

N 05°14'42" W, a distance of 136.88 feet to a 1/2 inch rebar set with cap stamped "G&A CONSULTANTS" in the south line of a called 10.942 acre tract of land described in deed to City of Rockwall, recorded in Instrument No. 2007-00389123, Deed Records, Rockwall County, Texas;

THENCE N 89°26'01" E, with the south line of said 10.942 acre tract, a distance of 15.52 feet to a 1/2 inch rebar set with cap stamped "G&A CONSULTANTS", being the southeast corner thereof;

THENCE N 00°10'47" W, with the east line of said 10.942 acre tract, a distance of 271.63 feet to a 1/2 inch rebar set with cap stamped "G&A CONSULTANTS", being the southwest corner of a 16.000 acre tract of land described as Tract 2 in deed to Betty Bogard, recorded in Instrument No. 2008-00396742, Deed Records, Rockwall County, Texas;

THENCE N 89°54'11" E, with the south line of said 16.000 acres, a distance of 842.15 feet to a 1/2 inch rebar set with cap stamped "G&A CONSULTANTS", being the southeast corner thereof and being in the west line of said 73.2744 acre tract;

Exhibit 'A':
Legal Description

THENCE S 01°28'09" E, with the west line of said 73.2744 acre tract of land, a distance of 845.72 feet to a 1/2 inch rebar set with cap stamped "G&A CONSULTANTS";

THENCE over, across, and through said 73.2744 acre tract the following five (5) courses and distances:

S 37°47'00" E, a distance of 135.09 feet to a 1/2 inch rebar set with cap stamped "G&A CONSULTANTS";

N 88°31'51" E, a distance of 259.75 feet to a 1/2 inch rebar set with cap stamped "G&A CONSULTANTS";

S 66°00'00" E, a distance of 266.78 feet to a 1/2 inch rebar set with cap stamped "G&A CONSULTANTS";

S 30°00'00" R, a distance of 384.58 feet to a 1/2 inch rebar set with cap stamped "G&A CONSULTANTS";

S 64°00'00" E, a distance of 352.92 feet to a 1/2 inch rebar set with cap stamped "G&A CONSULTANTS", being in the south line of said 73.2744 acre tract and the north line of U.S. Highway 66;

THENCE S 89°18'14" W, with the south line of said 73.2744 acre tract, and the north line of U.S. Highway 66, a distance of 1077.53 feet to the *POINT OF BEGINNING* and containing approximately 37.800 acres of land.

Exhibit 'C':
PD Development Standards

PD Development Standards.

Tract 1: 9.894-Acres of Non-Residential Property

- (1) *Permitted Uses.* Unless specifically provided by this Planned Development ordinance, only those uses permitted within the General Retail (GR) District, as stipulated by the *Permissible Use Charts* contained in Article IV, *Permissible Uses*, of the Unified Development Code (UDC) [Ordinance No. 04-38] as heretofore amended, as amended herein by granting this zoning change, and as maybe amended in the future are permitted on *Tract 1* of the *Subject Property*; however, the following additions and conditions shall apply:

The following land uses shall be expressly prohibited on the *Subject Property*:

- Convent or Monastery
- Hotel or Motel
- Hotel, Residence
- Cemetery/Mausoleum
- Mortuary or Funeral Chapel
- Social Service Provider
- Billiard Parlor or Pool Hall
- Carnival, Circus, or Amusement Ride
- Commercial Amusement/Recreation (*Outside*)
- Gun Club, Skeet or Target Range (*Indoor*)
- Astrologer, Hypnotist, or Psychic Art and Science
- Night Club, Discotheque, or Dance Hall
- Secondhand Dealer
- Car Wash, Self Service
- Retail Store with Gasoline Product Sales (*Any Amount of Dispensers*)
- Service Station
- Mining and Extraction (*Sand, Gravel, Oil & Other*)
- Helipad
- Railroad Yard or Shop
- Transit Passenger Facility

The following additional use shall be permitted through a Specific Use Permit (SUP) on the *Subject Property*:

- Garden Supply/Plant Nursery

- (2) *Density and Dimensional Requirements.* Any development on *Tract 1* of the *Subject Property* shall be subject to the development standards required for properties in a General Retail (GR) District as stipulated by Article V, *District Development Standards*, of the Unified Development Code [Ordinance No. 04-38] as heretofore amended, as amended herein by granting this zoning change, and as maybe amended in the future.

- (3) *Landscape Buffers.* All landscape buffers and plantings located within the buffers shall adhere to the following:

- (a) *Landscape Buffer (SH-66).* A minimum of a 15-foot landscape buffer shall be provided along the frontage of SH-66 (*outside of and beyond any required right-of-way dedication*), and shall incorporate ground cover, a *built-up* berm and/or shrubbery or a combination thereof along the entire length of the frontage. Berms and/or shrubbery shall have a minimum height of 30-inches and a maximum height of 48-inches. In addition, two (2) canopy trees and four (4) accent trees shall be planted per 100-feet of linear frontage. The developer shall also be responsible for the construction of a five (5) foot sidewalk situated within the 15-foot landscape buffer adjacent to SH-66.

Exhibit 'C':
PD Development Standards

- (b) *Landscape Buffer and Sidewalks (John King Boulevard)*. A minimum of a 15-foot landscape buffer shall be provided along the frontage of John King Boulevard (*outside of and beyond any required right-of-way dedication*), and shall incorporate ground cover, a *built-up* berm and/or shrubbery or a combination thereof along the entire length of the frontage. Berms and/or shrubbery shall have a minimum height of 30-inches and a maximum height of 48-inches. In addition, two (2) canopy trees and four (4) accent trees shall be planted per 100-feet of linear frontage. The developer shall also be responsible for the construction of a ten (10) foot sidewalk situated within the 15-foot landscape buffer adjacent to John King Boulevard.

- (c) *Landscape Buffer (FM-1141)*. A minimum of a 15-foot landscape buffer shall be provided along the frontage of FM-1141 (*outside of and beyond any required right-of-way dedication*), and shall incorporate ground cover, a *built-up* berm and/or shrubbery or a combination thereof along the entire length of the frontage. Berms and/or shrubbery shall have a minimum height of 30-inches and a maximum height of 48-inches. In addition, two (2) canopy trees and four (4) accent trees shall be planted per 100-feet of linear frontage. The developer shall also be responsible for the construction of a five (5) foot sidewalk situated within the 15-foot landscape buffer adjacent to FM-1141.

- (4) *Intersection Enhancements*. In accordance with the *John King Boulevard Design Concept Plan* the applicant shall be required to provide an intersection enhancement at the corner of the intersection of Williams Street (SH-66) and John King Boulevard that generally conforms to the following design:

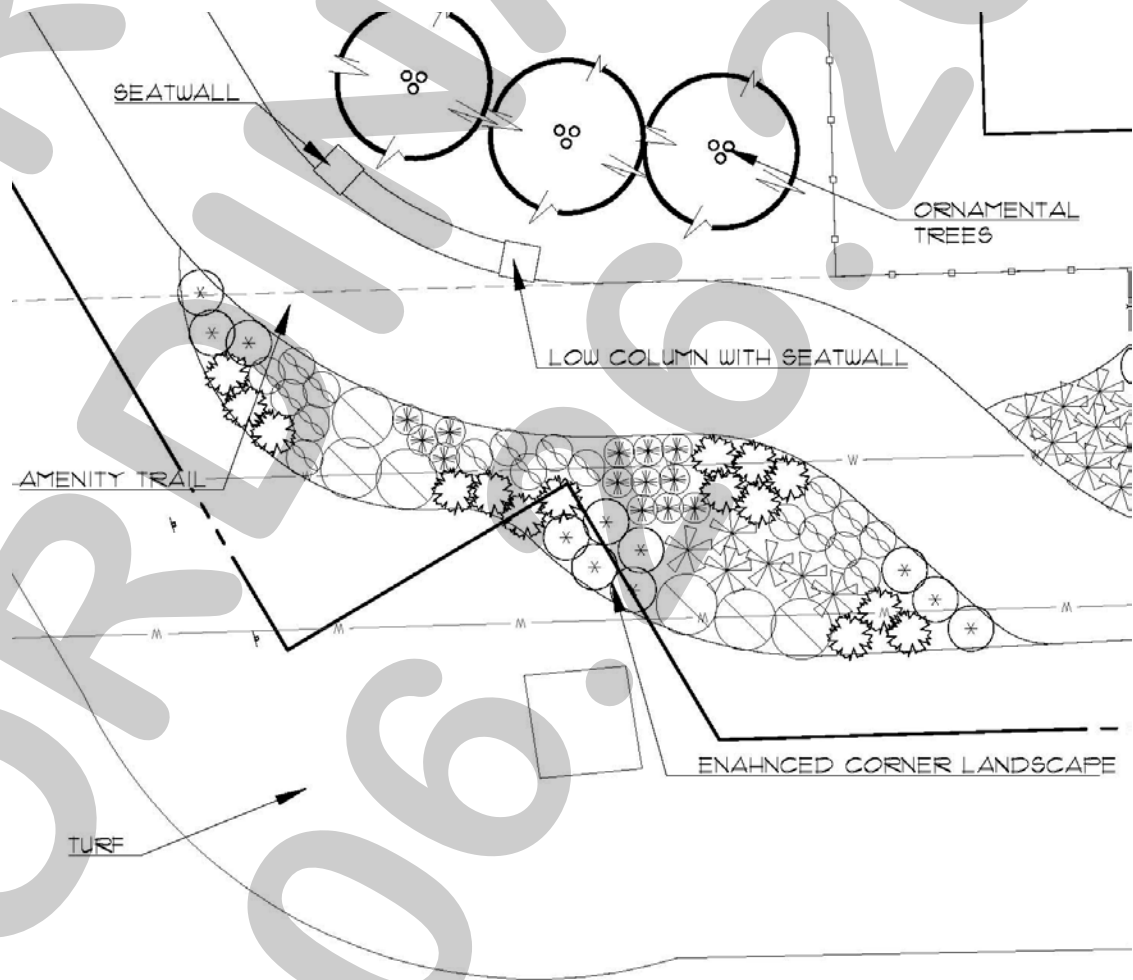

Exhibit 'C':
PD Development Standards

Tract 2: 28.011-Acres of Residential Property

(1) *Permitted Uses.* Unless specifically provided by this Planned Development ordinance, only those uses permitted within the Single Family 7 (SF-7) District, as stipulated by the *Permissible Use Charts* contained in Article IV, *Permissible Uses*, of the Unified Development Code (UDC) [Ordinance No. 04-38] as heretofore amended, as amended herein by granting this zoning change, and as maybe amended in the future are permitted on *Tract 2* of the *Subject Property*; however, the following additional land uses shall be permitted *by-right*:

- Activity Center
- Community Pool
- Gazebos/Pavilions
- Sports Courts

(2) *Unit Composition and Layout.* The unit composition and layout shall generally conform to the *Concept Plan* for *Tract 2* depicted in *Exhibit 'B'* and stated as follows:

| <i>Unit Type</i> | <i>Unit Dimensions</i> | <i>Minimum Unit Size (SF)</i> | <i>Dwelling Units (#)</i> | <i>Dwelling Units</i> |
|---------------------|------------------------|-------------------------------|---------------------------|-----------------------|
| 1 | 44.5' x 80' | 1,600 SF | 20 | 15.48% |
| 2 & 3 | 42' x 77' | 1,600 SF | 31 | 59.52% |
| 4 | 54' x 60' | 1,600 SF | 41 | 16.67% |
| 5 | 64' x 50' | 2,100 SF | 6 | 08.33% |
| <i>Total Units:</i> | | | 122 | |

(3) *Density and Dimensional Requirements.* The maximum permissible density for the *Subject Property* shall not exceed 3.2-units/acre; however, in no case should the proposed development exceed 122 single-family, residential units. The *Subject Property* shall maintain conformance with the following requirements:

- (a) *Condominium Requirement.* The property shall be established as a condominium development pursuant to the requirements of *Chapter 82* of the *Texas Property Code*, and platted as a single lot.
- (b) *Lot Dimensional Requirements.* The proposed condominium lot shall adhere to the following setbacks:

| | |
|--|------------|
| <i>Minimum Lot Width</i> | 1,500' |
| <i>Minimum Lot Depth</i> | 490' |
| <i>Minimum Lot Area</i> | 28.0-Acres |
| <i>Minimum Setback Adjacent to John King Boulevard</i> | 95' |
| <i>Minimum Setback Adjacent to SH-66</i> | 20' |
| <i>Minimum Setback Adjacent to the Eastern & Northern Property Lines</i> | 10' |

Continued on next page ...

Exhibit 'C':
PD Development Standards

- (c) *Internal Artificial Lot Requirements.* The units constructed on the proposed condominium lot shall adhere to the following dimensional requirements for artificial lots:

| | |
|--|-----|
| <i>Minimum Setback from a Private Street</i> ⁽¹⁾⁽²⁾⁽³⁾ | 15' |
| <i>Minimum Side Yard Distance Between Units</i> | 6' |
| <i>Minimum Side Yard Setback from a Private Street</i> ⁽¹⁾⁽²⁾ | 10' |
| <i>Minimum Rear Yard Distance Between Units</i> | 20' |
| <i>Maximum Height</i> | 35' |

General Notes:

- ¹: This setback shall be measured from the back of curb.
- ²: Variances of up to five (5) feet may be granted by the Director of Planning and Zoning on a case-by-case basis for artificial lots on curve-linear streets.
- ³: The minimum length of a driveway shall be 20-feet as measured from the edge of the approach to the garage door.

- (4) *Building Standards.* All development shall adhere to the following building standards:

- (A) *Masonry Requirement.* The minimum masonry requirement for the exterior façades -- excluding doors and windows -- of all buildings shall be 80%. For the purposes of this ordinance the masonry requirement shall be limited to full width brick, natural stone, and cultured stone. Cementaceous fiberboard horizontal lap-siding (e.g. *HardiBoard* or *Hardy Plank*) and/or stucco (i.e. three [3] part stucco or a comparable -- to be determined by staff) shall be permitted to be used to meet up to 40% of the masonry requirement.
- (B) *Roof Pitch.* A minimum of an 8:12 roof pitch is required on the front elevation of all structures. Porches and rear elevations shall have a minimum of a 4:12 roof pitch.
- (C) *Garage Orientation.* Garages shall oriented in a *traditional swing* (or *j-swing*) or in a front entry configuration. If a front entry garage configuration is utilized it shall face the street and shall be located even with the front building façade of the primary structure. On *traditional swing* (or *j-swing*) garages a second single garage door facing the street is permitted if it is located behind the width of the double garage door.
- (D) *Anti-Monotony Restrictions.* The development shall adhere to the following Anti-Monotony requirements (for spacing requirements see the illustration on the following page):
 - (1) Identical brick blends or paint colors may not occur on adjacent (side-by-side) properties along any block face without at least four (4) intervening homes of differing materials on the same side of the street beginning with the adjacent property and two (2) intervening homes of differing materials on the opposite side of the street.
 - (2) Front building elevations shall not repeat along any block face without at least four (4) intervening homes of differing appearance on the same side of the street and two (2) intervening homes of differing appearance on the opposite side of the street. Homes are considered to have a differing appearance if any of the following two (2) items deviate:
 - (a) Number of Stories
 - (b) Brick Color
 - (c) Roof Type and Layout
 - (d) Articulation of the Front Façade
 - (3) All roof shingles shall be an architectural or dimensional shingle, and have a 30-year rating. (*3-Tab Roofing Shingles are prohibited*).

Exhibit 'C':
PD Development Standards

Illustration 1: Properties line up on the opposite side of the street. Where RED are the same.



Illustration 2: Properties do not line up on opposite side of the street. Where RED are the same.



- (E) **Fencing Standards.** All residential privacy fencing shall be six (6) foot wrought iron/tubular steel fencing for transparent fencing and six (6) foot Simtek (or a similar product) fencing for non-transparent fencing. Fencing located along the exterior of the condominium lot shall be a minimum of six (6) foot wrought iron/tubular steel fencing with masonry columns a maximum of 45-feet on center. The masonry columns shall only be required adjacent to John King Boulevard and SH-66.
- (F) **Landscape and Hardscape Standards.**
- (1) **Residential Landscape.** All canopy trees planted within the condominium lot and not situated within a required landscape buffer shall be a minimum of three (3) inches in caliper and accent trees shall be a minimum of four (4) feet in height. All tree plantings shall conform to the City's tree planting guidelines and requirements stipulated in Appendix F, *Landscaping Guidelines and Requirements*, of the Unified Development Code.
 - (2) **Landscape Buffers.** All landscape buffers and plantings located within the buffers shall be maintained by the Homeowner's Association (HOA) and shall conform to the following:
 - (a) **Landscape Buffer (SH-66).** A minimum of a 20-foot landscape buffer shall be provided along the frontage of SH-66 (outside of and beyond any required right-of-way dedication), and shall incorporate ground cover, a built-up berm and shrubbery along the entire length of the frontage. Berms and/or shrubbery shall have a minimum height of 30-inches and a maximum height of 48-inches. The landscaping shall be generally as depicted below. The developer shall also be

Exhibit 'C':
PD Development Standards

responsible for the construction of a five (5) foot sidewalk situated within the 20-foot landscape buffer adjacent to SH-66.

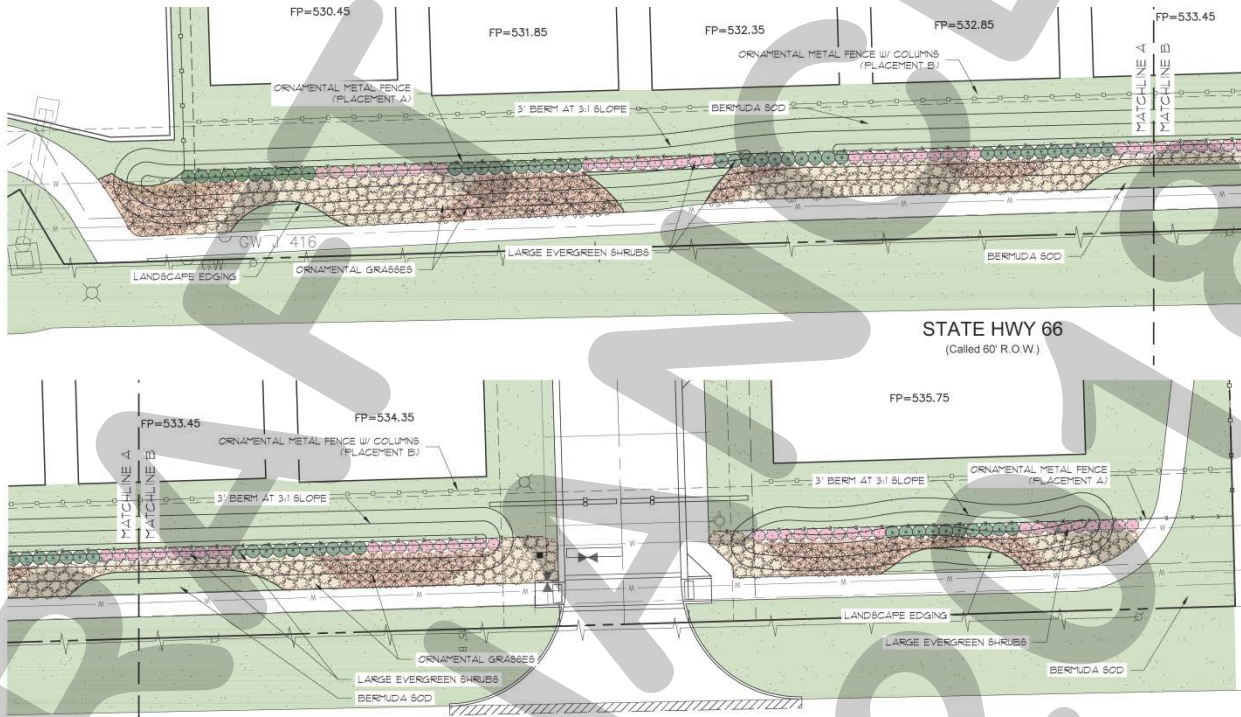

(b) *Landscape Buffer and Sidewalks (John King Boulevard)*. A minimum of a 50-foot landscape buffer shall be provided along the frontage of John King Boulevard (*outside of and beyond any required right-of-way dedication*), and shall incorporate ground cover, a *built-up* berm and/or shrubbery or a combination thereof along the entire length of the frontage. Berms and/or shrubbery shall have a minimum height of 30-inches. In addition, three (3) canopy trees and four (4) accent trees shall be planted per 100-feet of linear frontage. The developer shall also be responsible for the construction of a ten (10) foot sidewalk situated within the 50-foot landscape buffer adjacent to John King Boulevard. The required wrought iron fence along John King Boulevard may be situated within 40-feet of the right-of-way line. In addition, the design of the buffer shall generally conform to the following cross section:

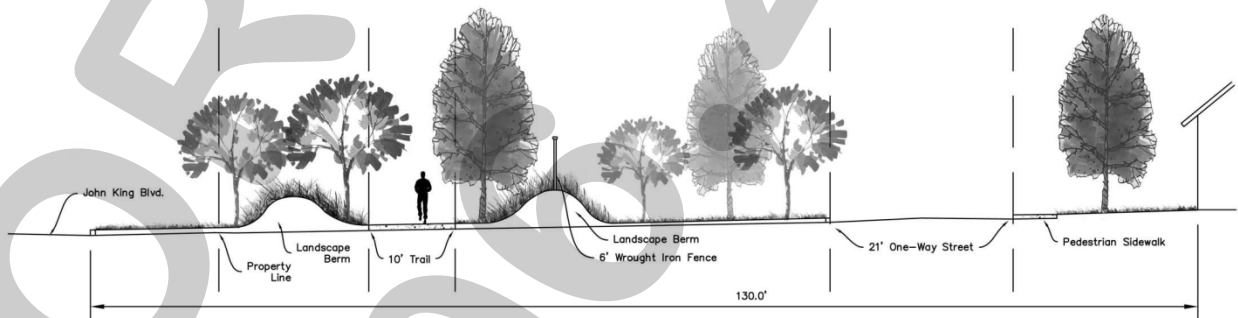
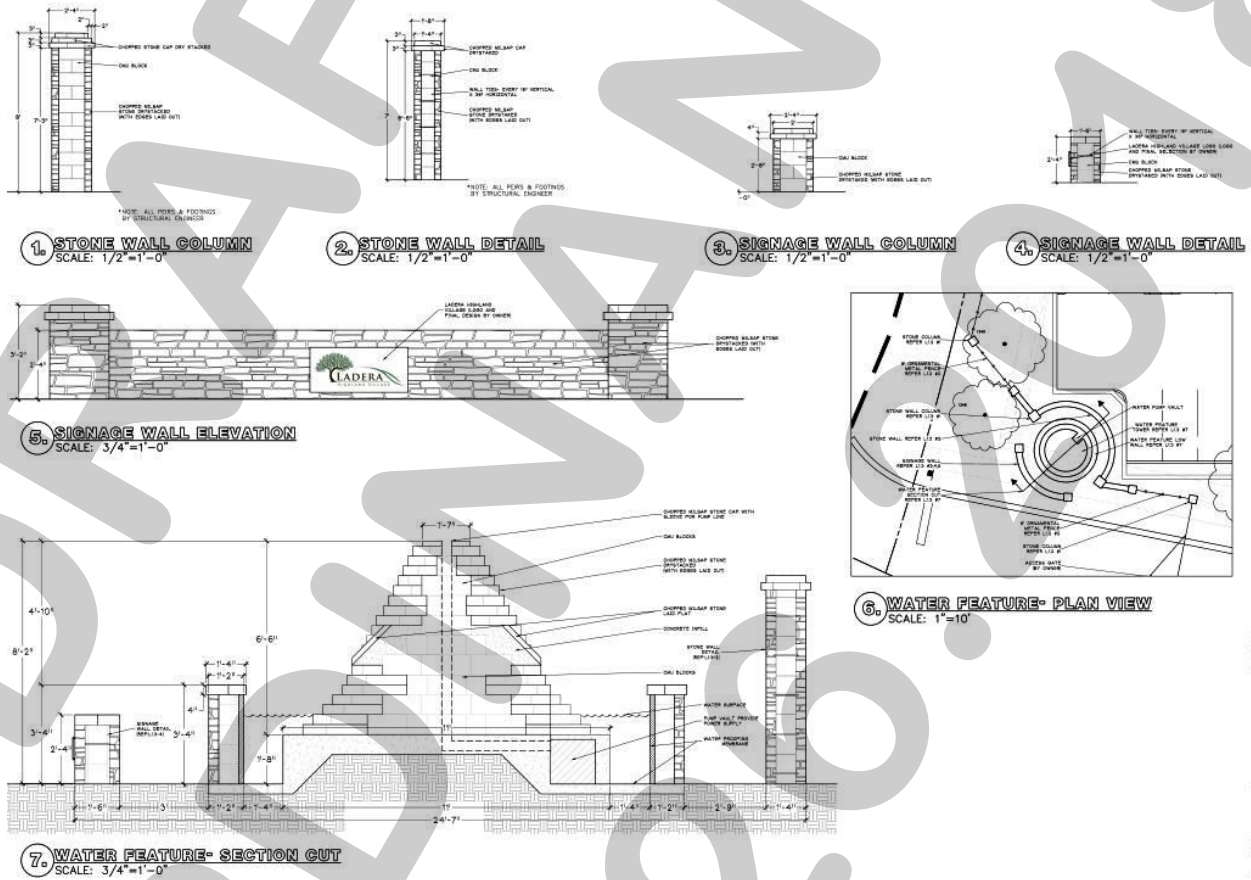

Exhibit 'C':
PD Development Standards

- (3) *Irrigation Requirements.* Irrigation shall be installed for all required landscaping located within common areas, landscape buffers and/or open space. Irrigation installed in these areas shall be designed by a Texas licensed irrigator or landscape architect and shall be maintained by the Homeowner's Association (HOA).
- (4) *Hardscape.* Hardscape plans indicating the location of all sidewalks and trails shall be reviewed and approved with the *PD Site Plan*.
- (G) *Trail Enhancements.* In accordance with the *John King Boulevard Design Concept Plan* the applicant shall be required to provide a trail enhancement element that generally conforms to the following design:



- (H) *Lighting.* Light poles shall not exceed 20-feet in total height (*i.e. base and lighting standard*). All fixtures shall be directed downward and be positioned to concentrate light within the development area.

Continued on next page ...

Exhibit 'C':
PD Development Standards

- (I) *Private Streets.* With the exception of the 21-foot, one-way street situated adjacent to John King Boulevard the street cross sections for this development should conform to the following cross section:

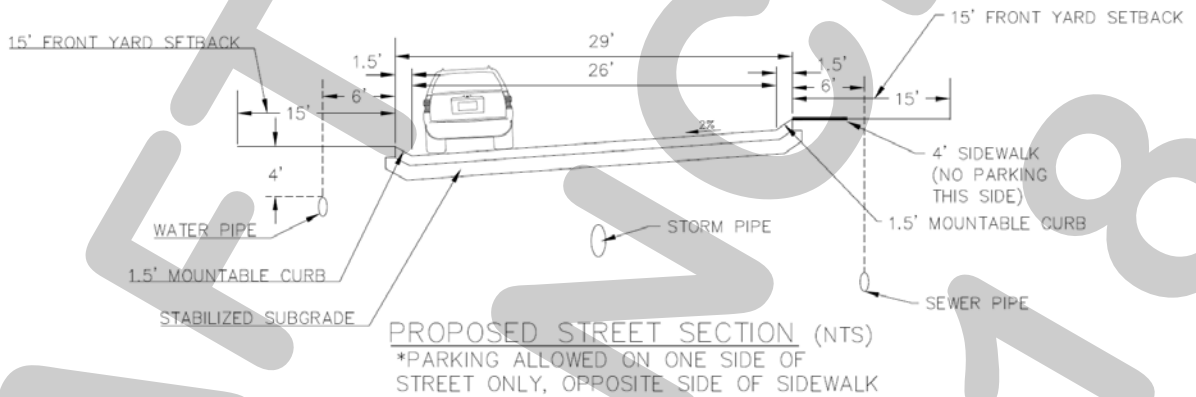

- (J) *Open Space.* The development shall consist of a minimum of 47.88% open space as calculated from the gross land area, and generally conform to the *Concept Plan* contained in *Exhibit 'B'* of this ordinance. The Homeowner's Association (HOA) shall maintain all common open space areas. For the purposes of this Planned Development District open space shall include all front yards, rear yards, common areas, buffers and floodplain installed by the developer, but does not include any landscaping, trees, patios and other improvements installed by the homeowner. Floodplain shall be calculated at a rate of 50% (e.g. ½-acre for every acre provided).
- (K) *Neighborhood Signage.* Permanent subdivision identification signage shall be permitted at all major entry points for the proposed subdivision. Final design and location of any entry features shall be reviewed and approved with the *PD Site Plan*.
- (L) *Condominium Owner's Association (COA).* A Condominium Owner's Association shall be created to enforce the restrictions established in accordance with the requirements of *Chapter 82, Uniform Condominium Act, of the Texas Property Code*. The COA shall also maintain all neighborhood parks, trails, open space and common areas, irrigation, landscaping, amenity centers, and screening fences associated with this development, but it is not required to maintain additional landscaping or improvements added by the homeowner.
- (M) *Buried Utilities.* New distribution power-lines required to serve the *Subject Property* shall be placed underground, whether such lines are located internally or along the perimeter of the *Subject Property*, unless otherwise authorized by the City Council. New transmission power-lines, or distribution lines of a size not typically or cost effectively placed underground (*3-phase lines*), or additional lines that are added to existing poles, may be above ground, if located along the perimeter of the *Subject Property*. The *Developer* shall not be required to re-locate existing overhead power-lines along the perimeter of the *Subject Property*. Temporary power-lines constructed across undeveloped portions of the *Subject Property* to facilitate development phasing and looping may be allowed above ground, but shall not be considered existing lines at the time the area is developed, and if they are to become permanent facilities, such lines shall be placed underground pursuant to this paragraph. Franchise utilities shall be placed within a ten (10) foot public utility easement behind the sidewalk, between the home and the property line.

Exhibit 'C':
PD Development Standards

- (N) *Variances.* The variance procedures and standards for approval that are set forth in the Unified Development Code [*Ordinance No. 04-38*] shall apply to any application for variances to this ordinance.