



**CASE COVER SHEET**

City of Rockwall  
Planning and Zoning Department  
385 S. Goliad Street  
Rockwall, Texas 75087

**PLANNING & ZONING CASE NO.**

**PLANNING & ZONING FEE**

**PLATTING APPLICATION**

- MASTER PLAT
- PRELIMINARY PLAT
- FINAL PLAT
- REPLAT
- AMENDING OR MINOR PLAT
- PLAT REINSTATEMENT REQUEST

**SITE PLAN APPLICATION**

- SITE PLAN
- AMENDED SITE PLAN/ELEVATIONS/LANDSCAPING

**ZONING APPLICATION**

- ZONING CHANGE
- SPECIFIC USE PERMIT
- PD DEVELOPMENT PLAN

**OTHER APPLICATION**

- TREE REMOVAL
- VARIANCE REQUEST/SPECIAL EXCEPTIONS

**RECORD OF RECOMMENDATIONS, VOTING RECORDS, AND CONDITIONS OF APPROVAL**

**ARCHITECTURE REVIEW BOARD**

**PLANNING AND ZONING COMMISSION**

**CITY COUNCIL READING #1**

**CITY COUNCIL READING #2**

**CONDITIONS OF APPROVAL**

**NOTES**



# DEVELOPMENT APPLICATION

City of Rockwall  
Planning and Zoning Department  
385 S. Goliad Street  
Rockwall, Texas 75087

### STAFF USE ONLY

PLANNING & ZONING CASE NO. **MIS 2023 - 004**

**NOTE: THE APPLICATION IS NOT CONSIDERED ACCEPTED BY THE CITY UNTIL THE PLANNING DIRECTOR AND CITY ENGINEER HAVE SIGNED BELOW.**

DIRECTOR OF PLANNING: \_\_\_\_\_

CITY ENGINEER: \_\_\_\_\_

PLEASE CHECK THE APPROPRIATE BOX BELOW TO INDICATE THE TYPE OF DEVELOPMENT REQUEST [SELECT ONLY ONE BOX]:

#### PLATTING APPLICATION FEES:

- MASTER PLAT (\$100.00 + \$15.00 ACRE) <sup>1</sup>
- PRELIMINARY PLAT (\$200.00 + \$15.00 ACRE) <sup>1</sup>
- FINAL PLAT (\$300.00 + \$20.00 ACRE) <sup>1</sup>
- REPLAT (\$300.00 + \$20.00 ACRE) <sup>1</sup>
- AMENDING OR MINOR PLAT (\$150.00)
- PLAT REINSTATEMENT REQUEST (\$100.00)

#### SITE PLAN APPLICATION FEES:

- SITE PLAN (\$250.00 + \$20.00 ACRE) <sup>1</sup>
- AMENDED SITE PLAN/ELEVATIONS/LANDSCAPING PLAN (\$100.00)

#### ZONING APPLICATION FEES:

- ZONING CHANGE (\$200.00 + \$15.00 ACRE) <sup>1</sup>
- SPECIFIC USE PERMIT (\$200.00 + \$15.00 ACRE) <sup>1&2</sup>
- PD DEVELOPMENT PLANS (\$200.00 + \$15.00 ACRE) <sup>1</sup>

#### OTHER APPLICATION FEES:

- TREE REMOVAL (\$75.00)
- VARIANCE REQUEST/SPECIAL EXCEPTIONS (\$100.00) <sup>2</sup>

#### NOTES:

<sup>1</sup>: IN DETERMINING THE FEE, PLEASE USE THE EXACT ACREAGE WHEN MULTIPLYING BY THE PER ACRE AMOUNT. FOR REQUESTS ON LESS THAN ONE ACRE, ROUND UP TO ONE (1) ACRE.  
<sup>2</sup>: A **\$1,000.00** FEE WILL BE ADDED TO THE APPLICATION FEE FOR ANY REQUEST THAT INVOLVES CONSTRUCTION WITHOUT OR NOT IN COMPLIANCE TO AN APPROVED BUILDING PERMIT.

### PROPERTY INFORMATION [PLEASE PRINT]

ADDRESS **1670 Avonlea Dr**

SUBDIVISION \_\_\_\_\_ LOT \_\_\_\_\_ BLOCK \_\_\_\_\_

GENERAL LOCATION \_\_\_\_\_

### ZONING, SITE PLAN AND PLATTING INFORMATION [PLEASE PRINT]

CURRENT ZONING \_\_\_\_\_ CURRENT USE \_\_\_\_\_

PROPOSED ZONING \_\_\_\_\_ PROPOSED USE \_\_\_\_\_

ACREAGE \_\_\_\_\_ LOTS [CURRENT] \_\_\_\_\_ LOTS [PROPOSED] \_\_\_\_\_

**SITE PLANS AND PLATS:** BY CHECKING THIS BOX YOU ACKNOWLEDGE THAT DUE TO THE PASSAGE OF HB3167 THE CITY NO LONGER HAS FLEXIBILITY WITH REGARD TO ITS APPROVAL PROCESS, AND FAILURE TO ADDRESS ANY OF STAFF'S COMMENTS BY THE DATE PROVIDED ON THE DEVELOPMENT CALENDAR WILL RESULT IN THE DENIAL OF YOUR CASE.

### OWNER/APPLICANT/AGENT INFORMATION [PLEASE PRINT/CHECK THE PRIMARY CONTACT/ORIGINAL SIGNATURES ARE REQUIRED]

OWNER **Tim Wolf**  APPLICANT \_\_\_\_\_

CONTACT PERSON \_\_\_\_\_ CONTACT PERSON \_\_\_\_\_

ADDRESS **1670 Avonlea Dr** ADDRESS \_\_\_\_\_

CITY, STATE & ZIP **Rockwall TX 75087** CITY, STATE & ZIP \_\_\_\_\_

PHONE **214-662-6100** PHONE \_\_\_\_\_

E-MAIL **t.wolf@rockwalltexas.com** E-MAIL \_\_\_\_\_

### NOTARY VERIFICATION [REQUIRED]

BEFORE ME, THE UNDERSIGNED AUTHORITY, ON THIS DAY PERSONALLY APPEARED \_\_\_\_\_ [OWNER] THE UNDERSIGNED, WHO STATED THE INFORMATION ON THIS APPLICATION TO BE TRUE AND CERTIFIED THE FOLLOWING:

"I HEREBY CERTIFY THAT I AM THE OWNER FOR THE PURPOSE OF THIS APPLICATION; ALL INFORMATION SUBMITTED HEREIN IS TRUE AND CORRECT; AND THE APPLICATION FEE OF \$ \_\_\_\_\_ TO COVER THE COST OF THIS APPLICATION, HAS BEEN PAID TO THE CITY OF ROCKWALL ON THIS THE \_\_\_\_\_ DAY OF \_\_\_\_\_, 20\_\_\_\_. BY SIGNING THIS APPLICATION, I AGREE THAT THE CITY OF ROCKWALL (I.E. "CITY") IS AUTHORIZED AND PERMITTED TO PROVIDE INFORMATION CONTAINED WITHIN THIS APPLICATION TO THE PUBLIC. THE CITY IS ALSO AUTHORIZED AND PERMITTED TO REPRODUCE ANY COPYRIGHTED INFORMATION SUBMITTED IN CONJUNCTION WITH THIS APPLICATION, IF SUCH REPRODUCTION IS ASSOCIATED OR IN RESPONSE TO A REQUEST FOR PUBLIC INFORMATION."

GIVEN UNDER MY HAND AND SEAL OF OFFICE ON THIS THE \_\_\_\_\_ DAY OF \_\_\_\_\_, 20\_\_\_\_.

OWNER'S SIGNATURE \_\_\_\_\_

NOTARY PUBLIC IN AND FOR THE STATE OF TEXAS \_\_\_\_\_



MY COMMISSION EXPIRES \_\_\_\_\_

[\(855\) 691-0656](tel:8556910656)

**Trex** Fencing SRF

[FENCING](#)

[GATES](#)

[SPECS & DRAWINGS](#)

[GALLERY](#)

[CONTACT](#)

[FIND A CONTRACTOR](#)

[GET PRICING](#)

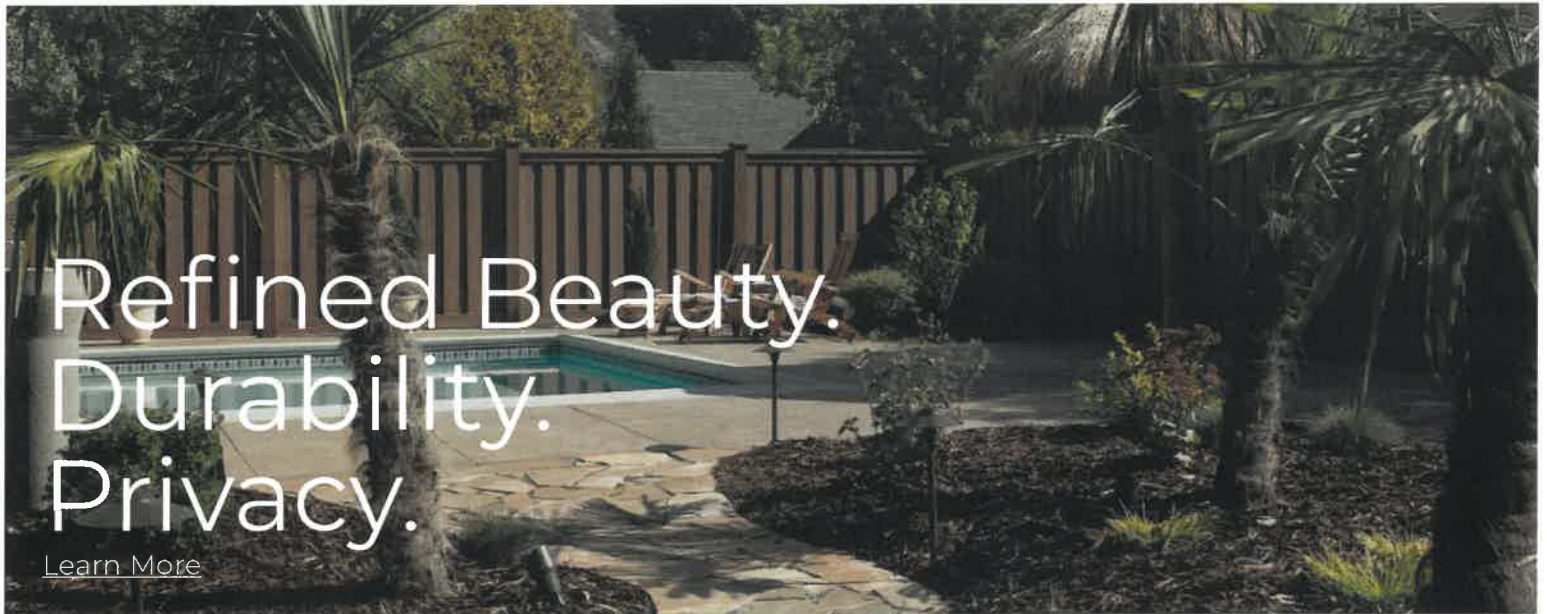

Refined Beauty.  
Durability.  
Privacy.

[Learn More](#)

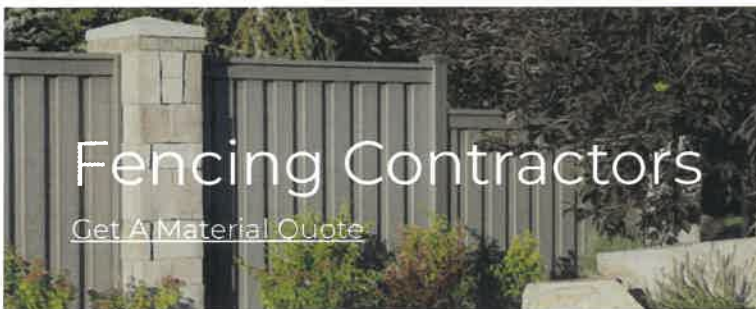

Fencing Contractors

[Get A Material Quote](#)



Homeowners

[Find a Contractor](#)

## Trex Composite Fencing & Gates

Trex Composite Fencing provides a beautiful, unique, low-maintenance alternative to wood and vinyl fences. Since 1996 Trex has invented, defined and perfected the composite deck category, becoming the world's largest manufacturer of wood-alternative decking products. Never content to settle, we continue to make strides in outdoor engineering, melding innovation with environmental responsibility and beautiful form with powerful function. Leveraging our success with decking led to the inclusion of other compatible products. Primary among them were composite fence panels, a unique and innovative application of material that had already proven its value. Blending unique design with precision and durability, Trex fence panels can be trusted to enrich your yard for years to come.



## Fencing Styles



Trex Seclusions



Trex Horizontal



Trex Horizons

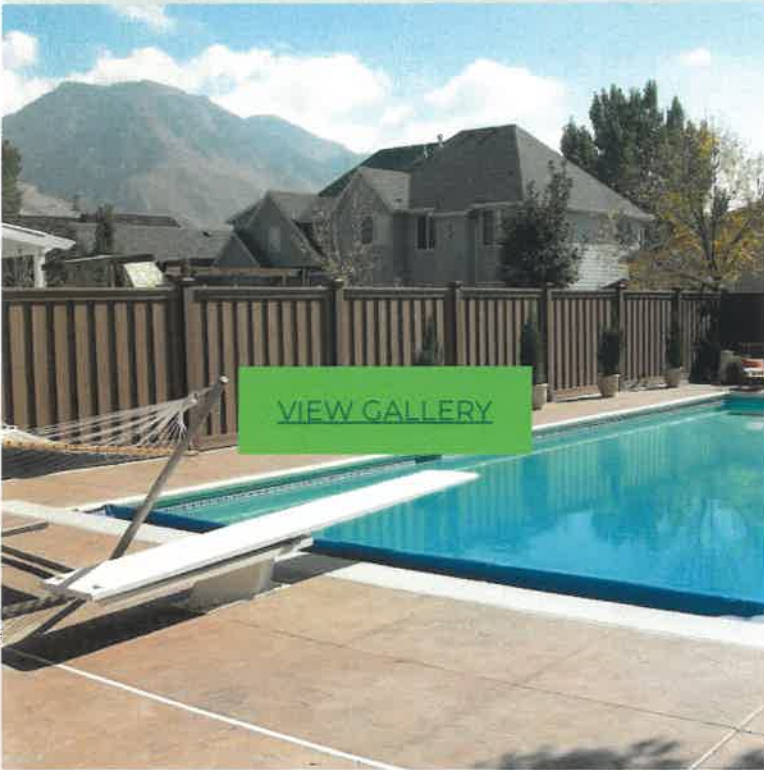

[VIEW GALLERY](#)

## Why Trex?

### Recycled Wood —

Reclaimed wood that would otherwise end up in a landfill finds its way into Trex high-performance composite materials. Composite wood fencing offers not just natural appeal, but durability and low maintenance. By using reclaimed sawdust, we never have had to cut down a tree to make our products. Ever.

### Recycled Plastic +

### Eco Friendly Manufacturing +

### The Big Picture +

(855) 691-0656

Trex Fencing SRF

[FENCING](#)

[GATES](#)

[SPECS & DRAWINGS](#)

[GALLERY](#)

[CONTACT](#)

[FIND A CONTRACTOR](#)

[GET PRICING](#)

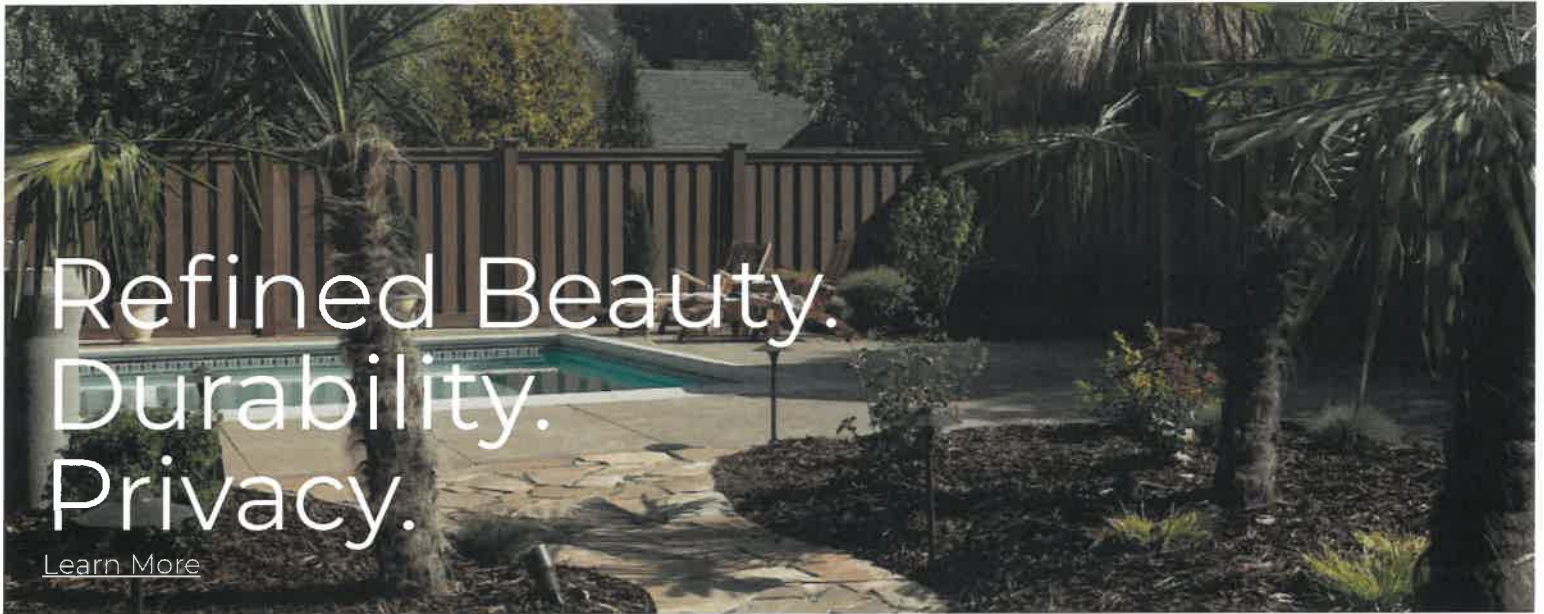

Refined Beauty.  
Durability.  
Privacy.

[Learn More](#)



Fencing Contractors

[Get A Material Quote](#)



Homeowners

[Find a Contractor](#)

## Trex Composite Fencing & Gates

Trex Composite Fencing provides a beautiful, unique, low-maintenance alternative to wood and vinyl fences. Since 1996 Trex has invented, defined and perfected the composite deck category, becoming the world's largest manufacturer of wood-alternative decking products. Never content to settle, we continue to make strides in outdoor engineering, melding innovation with environmental responsibility and beautiful form with powerful function. Leveraging our success with decking led to the inclusion of other compatible products. Primary among them were composite fence panels, a unique and innovative application of material that had already proven its value. Blending unique design with precision and durability, Trex fence panels can be trusted to enrich your yard for years to come.



## Fencing Styles



Trex Seclusions



Trex Horizontal



Trex Horizons



[VIEW GALLERY](#)

## Why Trex?

### Recycled Wood —

Reclaimed wood that would otherwise end up in a landfill finds its way into Trex high-performance composite materials. Composite wood fencing offers not just natural appeal, but durability and low maintenance. By using reclaimed sawdust, we never have had to cut down a tree to make our products. Ever.

### Recycled Plastic +

### Eco Friendly Manufacturing +

### The Big Picture +



## TREX® LIMITED WARRANTY

Trex Company, Inc. (hereinafter "Trex") warrants to the original purchaser ("Purchaser") that, for the period of time set forth in the following sentence, under normal use and service conditions, Trex® products shall be free from material defects in workmanship and materials, and shall not split, splinter, rot or suffer structural damage from termites or fungal decay. The term of such warranty shall be twenty-five (25) years from the date of original purchase for a residential application, and ten (10) years from the date of original purchase for a commercial application. If a defect occurs within the warranty period, Purchaser shall notify Trex in writing and, upon confirmation by an authorized Trex representative of the defect, Trex's sole responsibility shall be, at its option, to either replace the defective item or refund the portion of the purchase price paid by Purchaser for such defective item (not including the cost of its initial installation).

**Notwithstanding the foregoing, (a) the term of the warranty for the LED lights and housing for Trex® DeckLighting™ shall be seven (7) years, the term of the warranty for the LED lights and housing for Trex® LandscapeLighting™ shall be five (5) years, and the term of the warranty for the dimmer, timer and transformer for both shall be three (3) years, in each case provided that a Trex transformer is used (with no warranty on any components if a Trex transformer is not used), and any other parts or accessories shall not be warranted; (b) with respect to hardware for the Trex Surroundings® gate (gate frame, hinges and screws), the term of the warranty shall be five (5) years, (c) with respect to Trex Decorative Balusters, the term of the warranty covering the paint coating shall be ten (10) years, and shall be prorated in the following manner: 100% replacement for the first five (5) years; and 50% replacement for the next five (5) years, and (d) this warranty shall not apply to Trex Elevations® steel deck framing, Trex® Signature™/Reveal® aluminum railing and TrexTrim™ (which each have separate warranties).**

For purposes of this warranty, a "residential application" shall refer to an installation of the Product on an individual residence, and a "commercial application" shall refer to any installation of the Product other than on an individual residence.

**TO THE FULLEST EXTENT PERMITTED UNDER THE LAW, THIS WARRANTY SHALL NOT COVER AND TREX SHALL NOT BE RESPONSIBLE FOR COSTS AND EXPENSES INCURRED WITH RESPECT TO THE REMOVAL OF DEFECTIVE TREX PRODUCTS OR THE INSTALLATION OF REPLACEMENT MATERIALS, INCLUDING BUT NOT LIMITED TO LABOR AND FREIGHT.**

With respect to a residential application, this warranty may be transferred one (1) time, within the five (5) year period beginning from the date of original purchase by the Purchaser, to a subsequent buyer of the property upon which the Trex products were originally installed. With respect to a commercial application, this warranty is freely transferable to subsequent buyers of the property upon which the Trex products were originally installed.

To make a claim under this limited warranty, Purchaser, or the transferee, shall send to Trex, within the warranty period referred to above, a description of the claimed defect and proof of purchase, to the following address:

Trex Company, Inc.  
Customer Relations  
160 Exeter Drive  
Winchester, VA 22603-8605

Trex does not warrant against and is not responsible for any condition attributable to: (1) improper installation of Trex products and/or failure to abide by Trex's installation guidelines, including but not limited to improper gapping; (2) use of Trex products beyond normal use and service conditions, or in an application not recommended by Trex's guidelines and local building codes; (3) movement, distortion, collapse or settling of the ground or the supporting structure on which Trex products are installed; (4) any act of God (such as flooding, hurricane, earthquake, lightning, etc.), environmental condition (such as air pollution, mold, mildew, etc.), staining from foreign substances (such as dirt, grease, oil, etc.), or normal weathering (defined as exposure to sunlight, weather and atmosphere which will cause any colored surface to gradually fade, chalk, or accumulate dirt or stains); (5) variations or changes in color of Trex products; (6) improper handling, storage, abuse or neglect of Trex products by Purchaser, the transferee or third parties; or (7) ordinary wear and tear.

No person or entity is authorized by Trex to make and Trex shall not be bound by any statement or representation as to the quality or performance of Trex products other than as contained in this warranty. This warranty may not be altered or amended except in a written instrument signed by Trex and Purchaser.

**TO THE FULLEST EXTENT PERMITTED UNDER THE LAW, UNDER NO CIRCUMSTANCES WILL TREX BE LIABLE FOR INCIDENTAL OR CONSEQUENTIAL DAMAGES, WHETHER SUCH DAMAGES ARE SOUGHT IN CONTRACT, IN TORT (INCLUDING BUT NOT LIMITED TO NEGLIGENCE AND STRICT LIABILITY) OR OTHERWISE, AND TREX'S LIABILITY FOR NON-PERSONAL INJURY CLAIMS WITH RESPECT TO DEFECTIVE PRODUCTS SHALL IN NO EVENT EXCEED THE REPLACEMENT OF SUCH PRODUCTS OR REFUND OF THE PURCHASE PRICE, AS DESCRIBED ABOVE.**

Some States or Provinces do not allow the exclusion or limitation of incidental or consequential damages, so the above limitation or exclusion may not apply to you. This warranty gives you specific legal rights, and you may also have other rights that vary from State to State or Province to Province.

Copyright © 2018 Trex Company, Inc.



## TREX® LIMITED WARRANTY

Trex Company, Inc. (hereinafter "Trex") warrants to the original purchaser ("Purchaser") that, for the period of time set forth in the following sentence, under normal use and service conditions, Trex® products shall be free from material defects in workmanship and materials, and shall not split, splinter, rot or suffer structural damage from termites or fungal decay. The term of such warranty shall be twenty-five (25) years from the date of original purchase for a residential application, and ten (10) years from the date of original purchase for a commercial application. If a defect occurs within the warranty period, Purchaser shall notify Trex in writing and, upon confirmation by an authorized Trex representative of the defect, Trex's sole responsibility shall be, at its option, to either replace the defective item or refund the portion of the purchase price paid by Purchaser for such defective item (not including the cost of its initial installation).

**Notwithstanding the foregoing, (a), the term of the warranty for the LED lights and housing for Trex® DeckLighting™ shall be seven (7) years, the term of the warranty for the LED lights and housing for Trex® LandscapeLighting™ shall be five (5) years, and the term of the warranty for the dimmer, timer and transformer for both shall be three (3) years, in each case provided that a Trex transformer is used (with no warranty on any components if a Trex transformer is not used), and any other parts or accessories shall not be warranted; (b) with respect to hardware for the Trex Surroundings® gate (gate frame, hinges and screws), the term of the warranty shall be five (5) years, (c) with respect to Trex Decorative Balusters, the term of the warranty covering the paint coating shall be ten (10) years, and shall be prorated in the following manner: 100% replacement for the first five (5) years; and 50% replacement for the next five (5) years, and (d) this warranty shall not apply to Trex Elevations® steel deck framing, Trex® Signature™/Reveal® aluminum railing and TrexTrim™ (which each have separate warranties).**

For purposes of this warranty, a "residential application" shall refer to an installation of the Product on an individual residence, and a "commercial application" shall refer to any installation of the Product other than on an individual residence.

**TO THE FULLEST EXTENT PERMITTED UNDER THE LAW, THIS WARRANTY SHALL NOT COVER AND TREX SHALL NOT BE RESPONSIBLE FOR COSTS AND EXPENSES INCURRED WITH RESPECT TO THE REMOVAL OF DEFECTIVE TREX PRODUCTS OR THE INSTALLATION OF REPLACEMENT MATERIALS, INCLUDING BUT NOT LIMITED TO LABOR AND FREIGHT.**

With respect to a residential application, this warranty may be transferred one (1) time, within the five (5) year period beginning from the date of original purchase by the Purchaser, to a subsequent buyer of the property upon which the Trex products were originally installed. With respect to a commercial application, this warranty is freely transferable to subsequent buyers of the property upon which the Trex products were originally installed.

To make a claim under this limited warranty, Purchaser, or the transferee, shall send to Trex, within the warranty period referred to above, a description of the claimed defect and proof of purchase, to the following address:

Trex Company, Inc.  
Customer Relations  
160 Exeter Drive  
Winchester, VA 22603-8605

Trex does not warrant against and is not responsible for any condition attributable to: (1) improper installation of Trex products and/or failure to abide by Trex's installation guidelines, including but not limited to improper gapping; (2) use of Trex products beyond normal use and service conditions, or in an application not recommended by Trex's guidelines and local building codes; (3) movement, distortion, collapse or settling of the ground or the supporting structure on which Trex products are installed; (4) any act of God (such as flooding, hurricane, earthquake, lightning, etc.), environmental condition (such as air pollution, mold, mildew, etc.), staining from foreign substances (such as dirt, grease, oil, etc.), or normal weathering (defined as exposure to sunlight, weather and atmosphere which will cause any colored surface to gradually fade, chalk, or accumulate dirt or stains); (5) variations or changes in color of Trex products; (6) improper handling, storage, abuse or neglect of Trex products by Purchaser, the transferee or third parties; or (7) ordinary wear and tear.

No person or entity is authorized by Trex to make and Trex shall not be bound by any statement or representation as to the quality or performance of Trex products other than as contained in this warranty. This warranty may not be altered or amended except in a written instrument signed by Trex and Purchaser.

**TO THE FULLEST EXTENT PERMITTED UNDER THE LAW, UNDER NO CIRCUMSTANCES WILL TREX BE LIABLE FOR INCIDENTAL OR CONSEQUENTIAL DAMAGES, WHETHER SUCH DAMAGES ARE SOUGHT IN CONTRACT, IN TORT (INCLUDING BUT NOT LIMITED TO NEGLIGENCE AND STRICT LIABILITY) OR OTHERWISE, AND TREX'S LIABILITY FOR NON-PERSONAL INJURY CLAIMS WITH RESPECT TO DEFECTIVE PRODUCTS SHALL IN NO EVENT EXCEED THE REPLACEMENT OF SUCH PRODUCTS OR REFUND OF THE PURCHASE PRICE, AS DESCRIBED ABOVE.**

Some States or Provinces do not allow the exclusion or limitation of incidental or consequential damages, so the above limitation or exclusion may not apply to you. This warranty gives you specific legal rights, and you may also have other rights that vary from State to State or Province to Province.

Copyright © 2018 Trex Company, Inc.





# Trex® Fencing



REFINED BEAUTY.  
DURABILITY.  
PRIVACY.

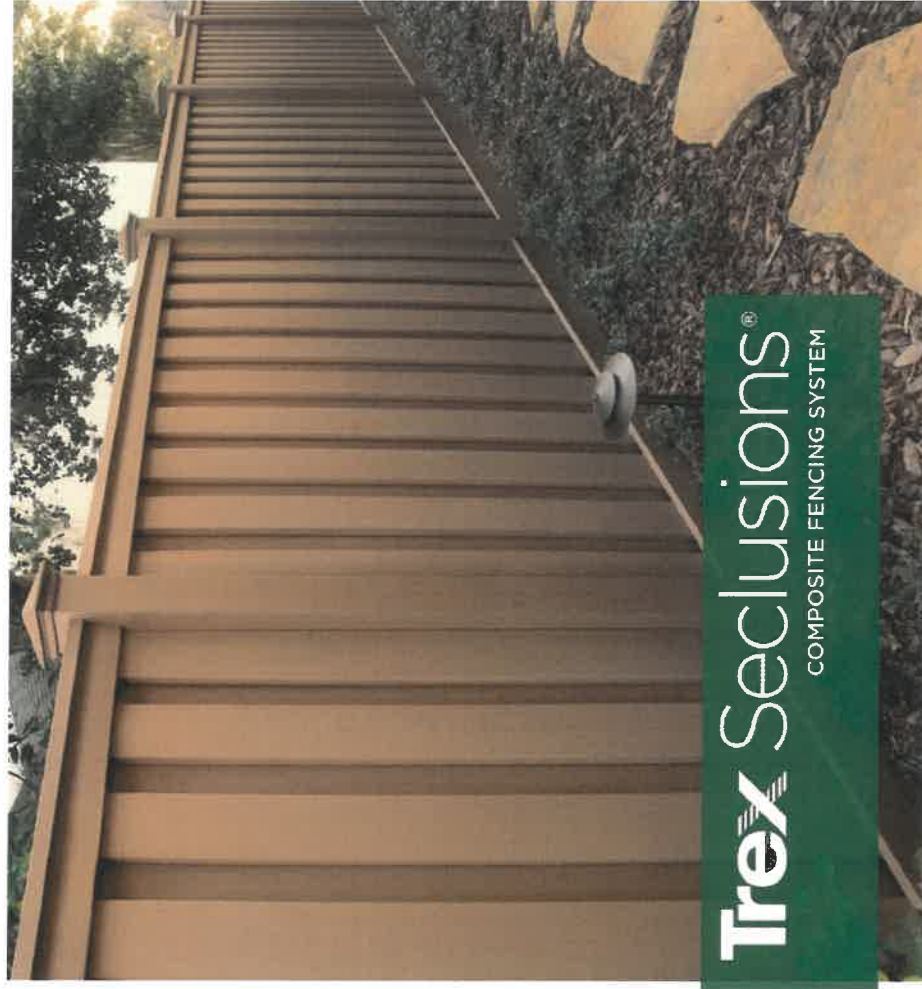

**Trex Seclusions®**  
COMPOSITE FENCING SYSTEM

**BEAUTY AND PRIVACY FROM EVERY ANGLE**  
Make your backyard a true masterpiece. Frame it with Trex Seclusions®. This composite fencing system offers the perfect backdrop to compliment any backyard paradise. With lasting beauty and low maintenance, it's the perfect fencing solution.



Learn more at  
[trexfencing.com/videos](http://trexfencing.com/videos)

**Trex®**  
OUTDOOR LIVING. DEFINED.  
Visit  
**trexfencing.com**

© 2016 Trex Company, Inc. All rights reserved. Trex®, the Trex logo and Trex Seclusions® are either federally registered trademarks, Trade marks or Trade dress of The Trex Company, Inc. Winchester, Virginia 10221016

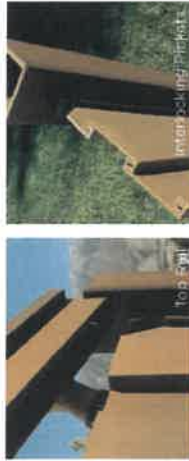

# Trex Fencing



REFINED BEAUTY.  
DURABILITY.  
PRIVACY.

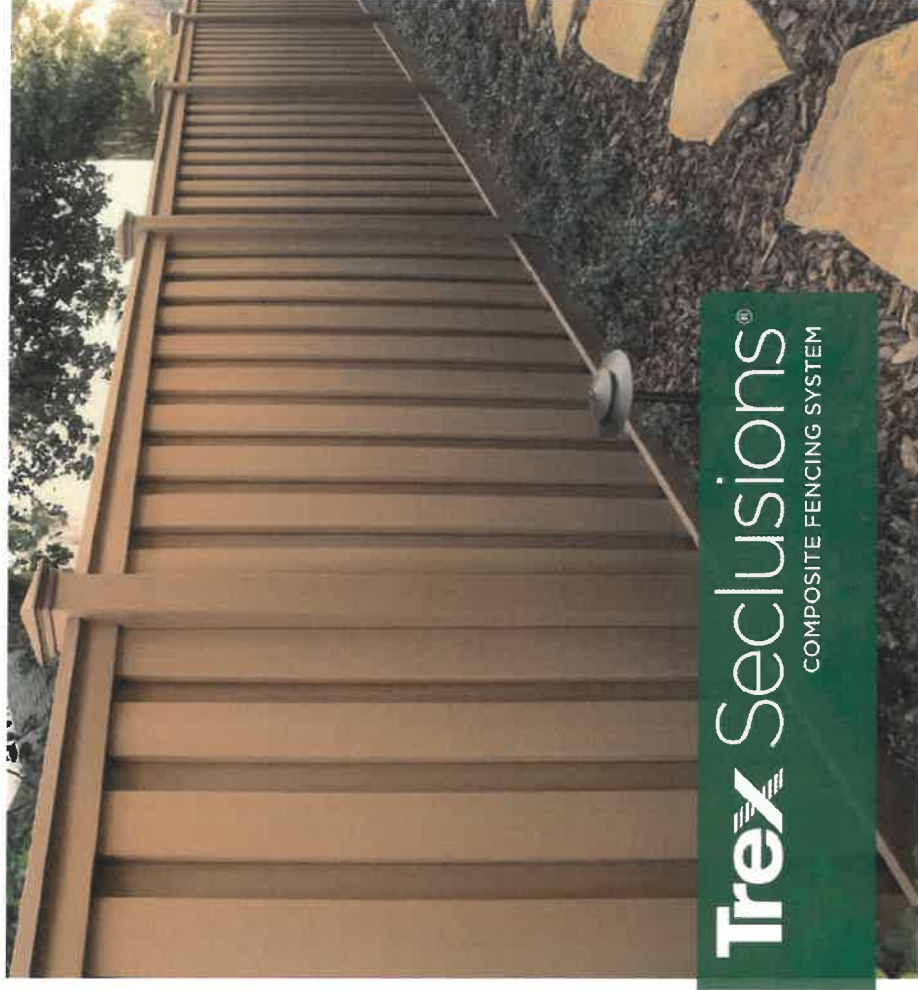

**Trex** Seclusions®  
COMPOSITE FENCING SYSTEM

**BEAUTY AND PRIVACY FROM EVERY ANGLE**  
Make your backyard a true masterpiece. Frame it with Trex Seclusions®. This composite fencing system offers the perfect backdrop to compliment any backyard paradise. With lasting beauty and low maintenance, it's the perfect fencing solution.



Learn more at  
[trexfencing.com/videos](http://trexfencing.com/videos)

**Trex**®

OUTDOOR LIVING, DEFINED.

Visit

[trexfencing.com](http://trexfencing.com)

©2016 Trex Company, Inc. All rights reserved. Trex®, the Trex logo and Trex Seclusions® are either federally registered trademarks, trade marks, or trade dress of The Trex Company, Inc., Winchester, Virginia.

102220115



# Trex® Seclusions® Composite Fencing

ARCHITECTURAL DRAWING:  
TREX SECLUSIONS FENCING  
PROFILE VIEW

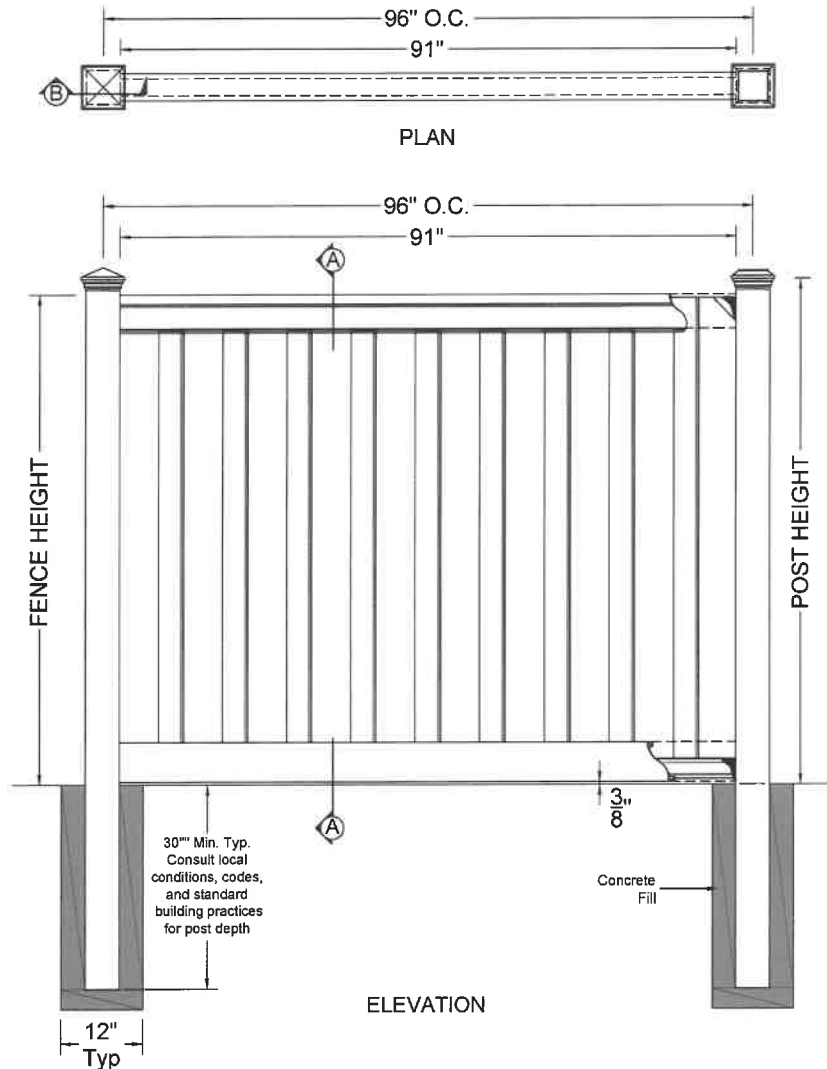

BILL OF MATERIAL FOR A 6'H x 8'W SECTION OF SECLUSIONS FENCINGS		
COMPONENTS	QUANTITY	LENGTH
Post Cap: Pyramid, Flat, or Crown	1	
5" x 5" Post	1	106" *
4" x 4.9" Top Rail	1	91" *
1"x5.75" Interlocking Picket	19	67" *
1" x 5.75" Bottom Rail Cover	2	91" *
Aluminum Bottom Rail	1	90 1/2"
Fence Bracket	4	
1 5/8" (Typ) Exterior Wood Screws	24	

\* Length may vary

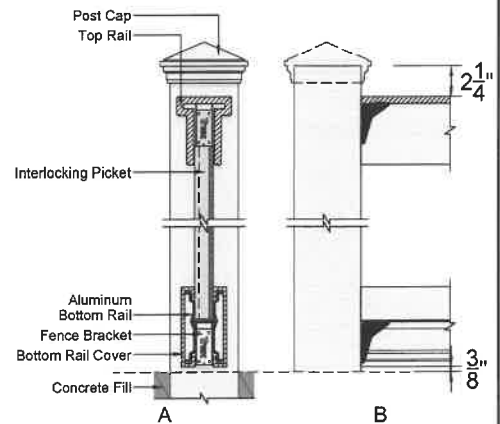

SECTIONS

**NOTES:**

1. INSTALLATION TO BE COMPLETED PER MANUFACTURER'S SPECIFICATION.
2. THIS DRAWING IS PROVIDED FOR PLANNING PURPOSES. REFER TO MANUFACTURER'S INSTALLATIONS FOR CONSTRUCTION DETAILS.
3. REFER TO MANUFACTURER'S WEBSITE FOR PRODUCT INFORMATION.
4. DRAWING NOT TO SCALE.

## TREX SECLUSIONS FENCING PROFILE VIEW

160 EXETER DR, WINCHESTER, VA 22603  
1-800-BUY-TREX / WWW.TREXFENCING.COM



# Trex® Seclusions® Composite Fencing

ARCHITECTURAL DRAWING:  
TREX SECLUSIONS FENCING  
PROFILE VIEW

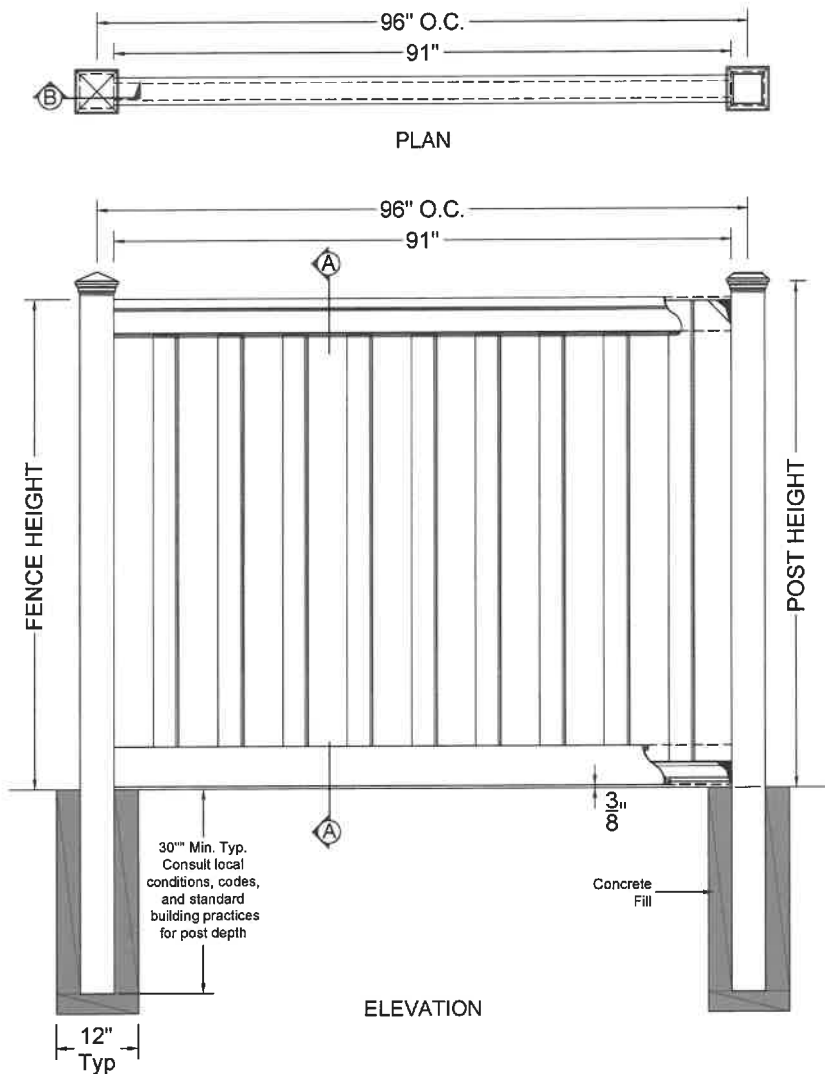

COMPONENTS	QUANTITY	LENGTH
Post Cap: Pyramid, Flat, or Crown	1	
5" x 5" Post	1	106" *
4" x 4.9" Top Rail	1	91" *
1"x5.75" Interlocking Picket	19	67" *
1" x 5.75" Bottom Rail Cover	2	91" *
Aluminum Bottom Rail	1	90 1/2"
Fence Bracket	4	
1 5/8" (Typ) Exterior Wood Screws	24	

\* Length may vary

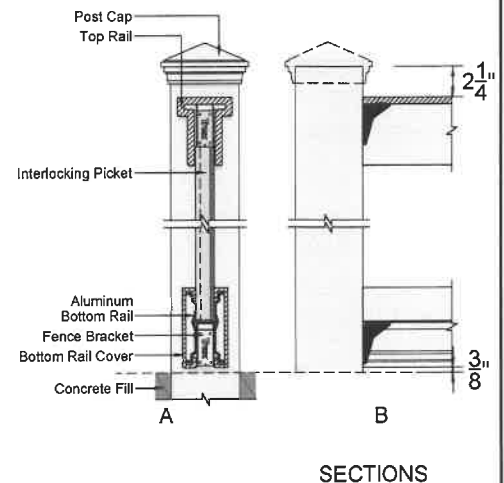

**NOTES:**

1. INSTALLATION TO BE COMPLETED PER MANUFACTURER'S SPECIFICATION.
2. THIS DRAWING IS PROVIDED FOR PLANNING PURPOSES. REFER TO MANUFACTURER'S INSTALLATIONS FOR CONSTRUCTION DETAILS.
3. REFER TO MANUFACTURER'S WEBSITE FOR PRODUCT INFORMATION.
4. DRAWING NOT TO SCALE.

## TREX SECLUSIONS FENCING PROFILE VIEW

160 EXETER DR, WINCHESTER, VA 22603  
1-800-BUY-TREX / WWW.TREXFENCING.COM

# Trex® Seclusions®

## COMPOSITE FENCING SYSTEM

ARCHITECTURAL DRAWING:  
TREX SECLUSIONS FENCING  
6' TALL x 8' WIDE

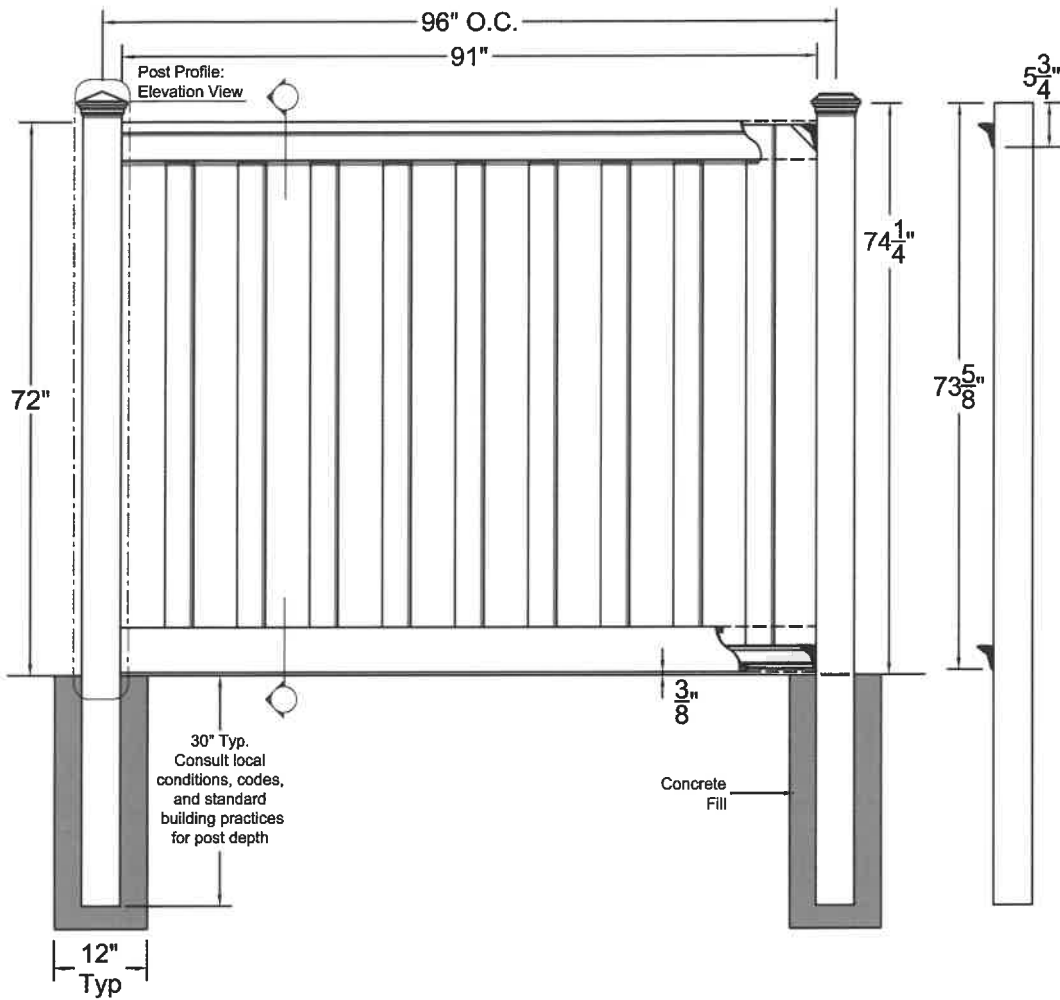

COMPONENTS	QUANTITY	LENGTH
Post Cap: Pyramid, Flat, or Crown	1	
5" x 5" Post	1	108" *
4" x 4.9" Top Rail	1	91" *
1" x 5.75" Interlocking Picket	19	67" *
1" x 5.75" Bottom Rail Cover	2	91" *
Aluminum Bottom Rail	1	90 1/2"
Fence Bracket	4	
1 5/8" (Typ) Exterior Wood Screws	24	

\* Length may vary

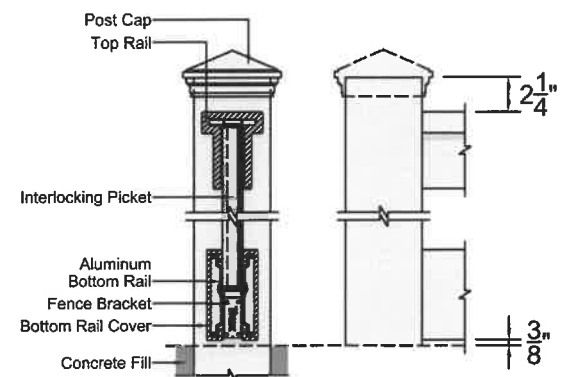

Post Profile: Cut View / Elevation View

### NOTES:

1. INSTALLATION TO BE COMPLETED PER MANUFACTURER'S SPECIFICATION.
2. THIS DRAWING IS PROVIDED FOR PLANNING PURPOSES. REFER TO MANUFACTURER'S INSTALLATIONS FOR CONSTRUCTION DETAILS.
3. REFER TO MANUFACTURER'S WEBSITE FOR PRODUCT INFORMATION.
4. DRAWING NOT TO SCALE.

160 EXETER DR., WINCHESTER VA, 22603

WWW.TREXFENCING.COM

Trex®, the Trex® logo, and Trex Seclusions® are either federally registered trademarks, trademarks or trade dress of Trex Company, Inc., Winchester Virginia or its licensees.  
Copyright © 2019 RIA Designs. All rights reserved.

# Trex® Seclusions®

## COMPOSITE FENCING SYSTEM

ARCHITECTURAL DRAWING:  
TREX SECLUSIONS FENCING  
6' TALL x 8' WIDE

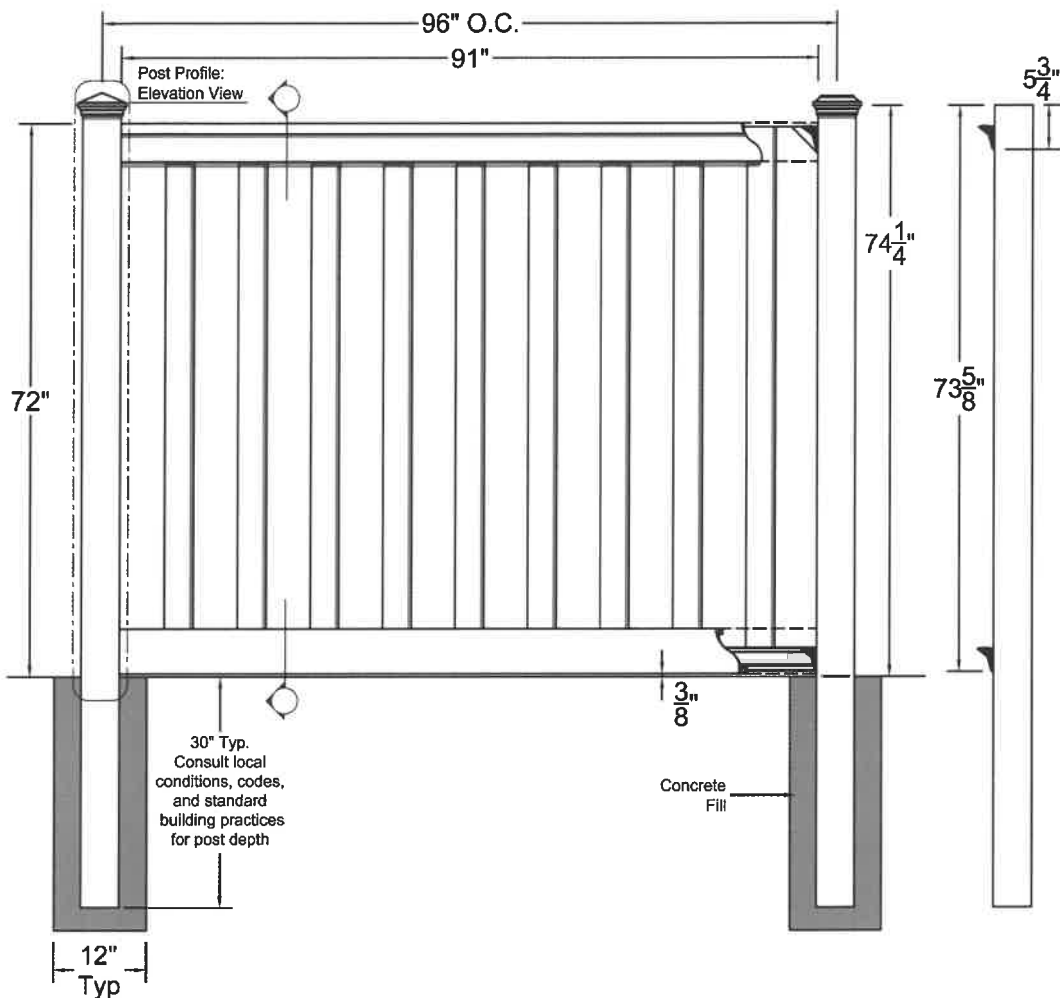

COMPONENTS	QUANTITY	LENGTH
Post Cap: Pyramid, Flat, or Crown	1	
5" x 5" Post	1	108" *
4" x 4.9" Top Rail	1	91" *
1"x5.75" Interlocking Picket	19	67" *
1" x 5.75" Bottom Rail Cover	2	91" *
Aluminum Bottom Rail	1	90 1/2"
Fence Bracket	4	
1 5/8" (Typ) Exterior Wood Screws	24	

\* Length may vary

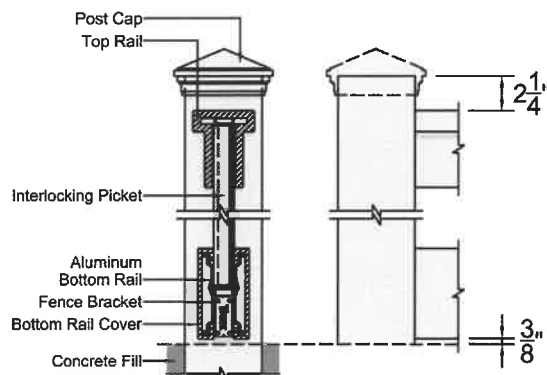

Post Profile: Cut View / Elevation View

### NOTES:

1. INSTALLATION TO BE COMPLETED PER MANUFACTURER'S SPECIFICATION.
2. THIS DRAWING IS PROVIDED FOR PLANNING PURPOSES. REFER TO MANUFACTURER'S INSTALLATIONS FOR CONSTRUCTION DETAILS.
3. REFER TO MANUFACTURER'S WEBSITE FOR PRODUCT INFORMATION.
4. DRAWING NOT TO SCALE.

160 EXETER DR., WINCHESTER VA, 22603

WWW.TREXFENCING.COM

Trex®, the Trex® logo, and Trex Seclusions® are either federally registered trademarks, trademarks or trade dress of Trex Company, Inc., Winchester Virginia or its licensees. Copyright © 2019 RI A Designs. All rights reserved.



# Trex® Seclusions® Composite Fencing

ARCHITECTURAL DRAWING:  
TREX SECLUSIONS FENCING  
PROFILE VIEW

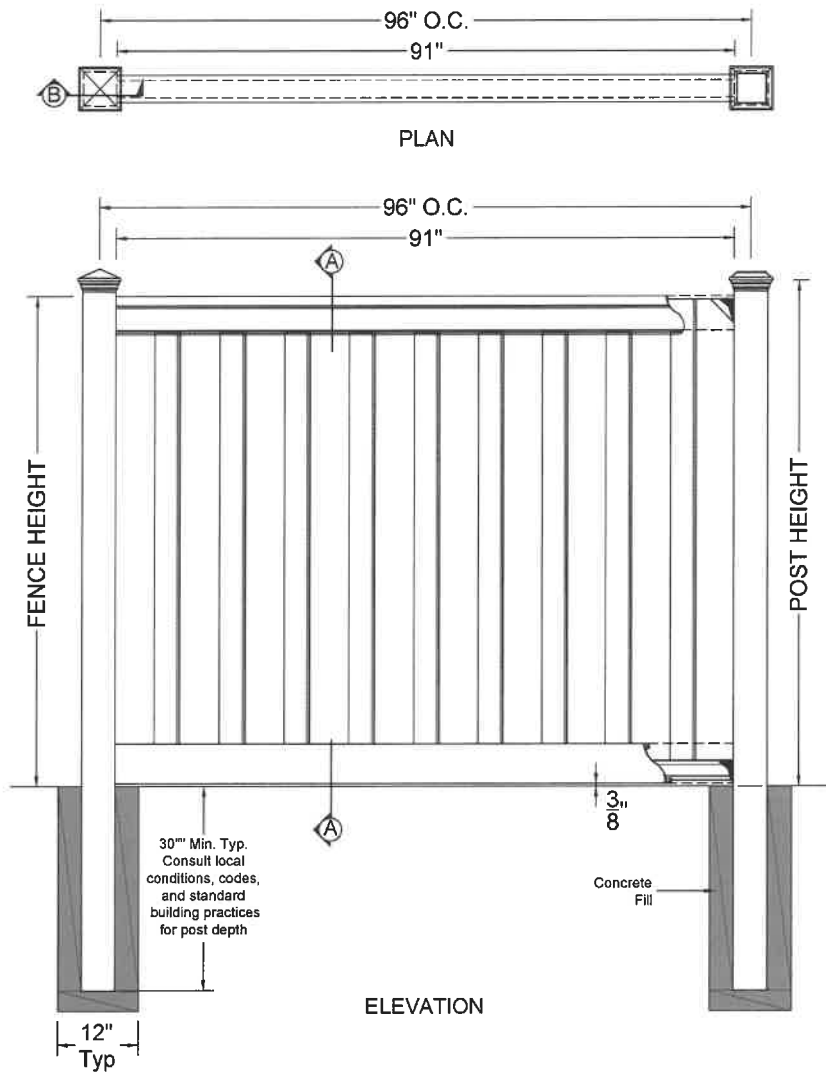

**BILL OF MATERIAL FOR A 6'H x 8'W SECTION OF SECLUSIONS FENCINGS**

COMPONENTS	QUANTITY	LENGTH
Post Cap: Pyramid, Flat, or Crown	1	
5" x 5" Post	1	106" *
4" x 4.9" Top Rail	1	91" *
1"x5.75" Interlocking Picket	19	67" *
1" x 5.75" Bottom Rail Cover	2	91" *
Aluminum Bottom Rail	1	90 1/2"
Fence Bracket	4	
1 5/8" (Typ) Exterior Wood Screws	24	

\* Length may vary

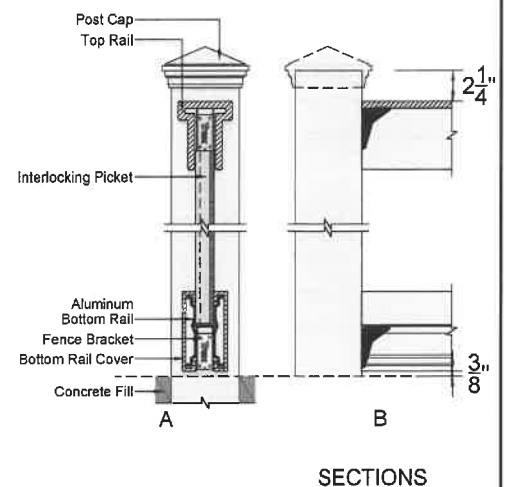

**NOTES:**

1. INSTALLATION TO BE COMPLETED PER MANUFACTURER'S SPECIFICATION.
2. THIS DRAWING IS PROVIDED FOR PLANNING PURPOSES. REFER TO MANUFACTURER'S INSTALLATIONS FOR CONSTRUCTION DETAILS.
3. REFER TO MANUFACTURER'S WEBSITE FOR PRODUCT INFORMATION.
4. DRAWING NOT TO SCALE.

## TREX SECLUSIONS FENCING PROFILE VIEW

160 EXETER DR, WINCHESTER, VA 22603  
1-800-BUY-TREX / WWW.TREXFENCING.COM

# Trex® Seclusions® Composite Fencing

ARCHITECTURAL DRAWING:  
TREX SECLUSIONS FENCING  
PROFILE VIEW

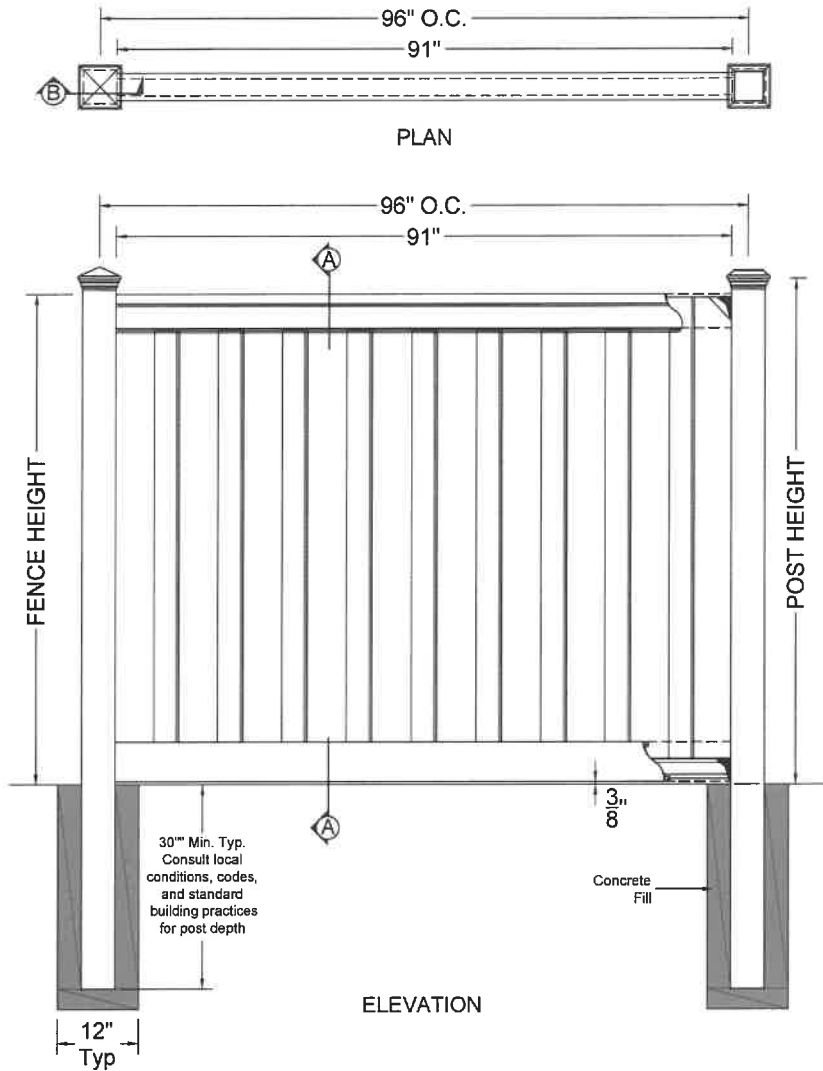

BILL OF MATERIAL FOR A  
6'H x 8'W SECTION OF  
SECLUSIONS FENCINGS

COMPONENTS	QUANTITY	LENGTH
Post Cap: Pyramid, Flat, or Crown	1	
5" x 5" Post	1	106" *
4" x 4.9" Top Rail	1	91" *
1"x5.75" Interlocking Picket	19	67" *
1" x 5.75" Bottom Rail Cover	2	91" *
Aluminum Bottom Rail	1	90 1/2"
Fence Bracket	4	
1 5/8" (Typ) Exterior Wood Screws	24	

\* Length may vary

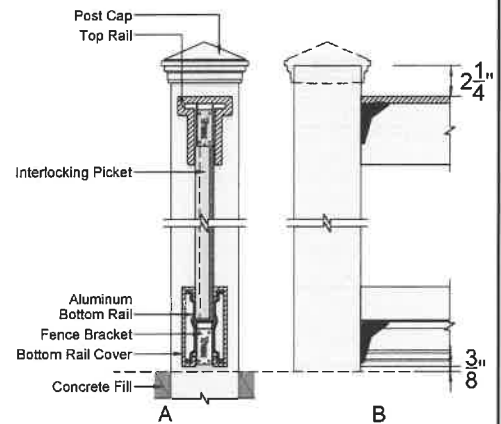

SECTIONS

**NOTES:**

1. INSTALLATION TO BE COMPLETED PER MANUFACTURER'S SPECIFICATION.
2. THIS DRAWING IS PROVIDED FOR PLANNING PURPOSES. REFER TO MANUFACTURER'S INSTALLATIONS FOR CONSTRUCTION DETAILS.
3. REFER TO MANUFACTURER'S WEBSITE FOR PRODUCT INFORMATION.
4. DRAWING NOT TO SCALE.

## TREX SECLUSIONS FENCING PROFILE VIEW

160 EXETER DR, WINCHESTER, VA 22603  
1-800-BUY-TREX / WWW.TREXFENCING.COM



# DEVELOPMENT APPLICATION

City of Rockwall  
Planning and Zoning Department  
385 S. Goliad Street  
Rockwall, Texas 75087

### STAFF USE ONLY

PLANNING & ZONING CASE NO. MIS 2023 - 004

**NOTE:** THE APPLICATION IS NOT CONSIDERED ACCEPTED BY THE CITY UNTIL THE PLANNING DIRECTOR AND CITY ENGINEER HAVE SIGNED BELOW.

DIRECTOR OF PLANNING: \_\_\_\_\_

CITY ENGINEER: \_\_\_\_\_

PLEASE CHECK THE APPROPRIATE BOX BELOW TO INDICATE THE TYPE OF DEVELOPMENT REQUEST [SELECT ONLY ONE BOX]:

#### PLATTING APPLICATION FEES:

- MASTER PLAT (\$100.00 + \$15.00 ACRE) <sup>1</sup>
- PRELIMINARY PLAT (\$200.00 + \$15.00 ACRE) <sup>1</sup>
- FINAL PLAT (\$300.00 + \$20.00 ACRE) <sup>1</sup>
- REPLAT (\$300.00 + \$20.00 ACRE) <sup>1</sup>
- AMENDING OR MINOR PLAT (\$150.00)
- PLAT REINSTATEMENT REQUEST (\$100.00)

#### SITE PLAN APPLICATION FEES:

- SITE PLAN (\$250.00 + \$20.00 ACRE) <sup>1</sup>
- AMENDED SITE PLAN/ELEVATIONS/LANDSCAPING PLAN (\$100.00)

#### ZONING APPLICATION FEES:

- ZONING CHANGE (\$200.00 + \$15.00 ACRE) <sup>1</sup>
- SPECIFIC USE PERMIT (\$200.00 + \$15.00 ACRE) <sup>1&2</sup>
- PD DEVELOPMENT PLANS (\$200.00 + \$15.00 ACRE) <sup>1</sup>

#### OTHER APPLICATION FEES:

- TREE REMOVAL (\$75.00)
- VARIANCE REQUEST/SPECIAL EXCEPTIONS (\$100.00) <sup>2</sup>

#### NOTES:

<sup>1</sup>: IN DETERMINING THE FEE, PLEASE USE THE EXACT ACREAGE WHEN MULTIPLYING BY THE PER ACRE AMOUNT. FOR REQUESTS ON LESS THAN ONE ACRE, ROUND UP TO ONE (1) ACRE.  
<sup>2</sup>: A **\$1,000.00** FEE WILL BE ADDED TO THE APPLICATION FEE FOR ANY REQUEST THAT INVOLVES CONSTRUCTION WITHOUT OR NOT IN COMPLIANCE TO AN APPROVED BUILDING PERMIT.

### PROPERTY INFORMATION [PLEASE PRINT]

ADDRESS 1670 Avonlea Dr

SUBDIVISION \_\_\_\_\_ LOT \_\_\_\_\_ BLOCK \_\_\_\_\_

GENERAL LOCATION \_\_\_\_\_

### ZONING, SITE PLAN AND PLATTING INFORMATION [PLEASE PRINT]

CURRENT ZONING \_\_\_\_\_ CURRENT USE \_\_\_\_\_

PROPOSED ZONING \_\_\_\_\_ PROPOSED USE \_\_\_\_\_

ACREAGE \_\_\_\_\_ LOTS [CURRENT] \_\_\_\_\_ LOTS [PROPOSED] \_\_\_\_\_

**SITE PLANS AND PLATS:** BY CHECKING THIS BOX YOU ACKNOWLEDGE THAT DUE TO THE PASSAGE OF HB3167 THE CITY NO LONGER HAS FLEXIBILITY WITH REGARD TO ITS APPROVAL PROCESS, AND FAILURE TO ADDRESS ANY OF STAFF'S COMMENTS BY THE DATE PROVIDED ON THE DEVELOPMENT CALENDAR WILL RESULT IN THE DENIAL OF YOUR CASE.

### OWNER/APPLICANT/AGENT INFORMATION [PLEASE PRINT/CHECK THE PRIMARY CONTACT/ORIGINAL SIGNATURES ARE REQUIRED]

OWNER Tim Wolf  APPLICANT \_\_\_\_\_

CONTACT PERSON \_\_\_\_\_ CONTACT PERSON \_\_\_\_\_

ADDRESS 1670 Avonlea Dr ADDRESS \_\_\_\_\_

CITY, STATE & ZIP Rockwall TX 75087 CITY, STATE & ZIP \_\_\_\_\_

PHONE 214-662-6100 PHONE \_\_\_\_\_

E-MAIL t.wolf@rockwalltexas.com E-MAIL \_\_\_\_\_

### NOTARY VERIFICATION [REQUIRED]

BEFORE ME, THE UNDERSIGNED AUTHORITY, ON THIS DAY PERSONALLY APPEARED \_\_\_\_\_ [OWNER] THE UNDERSIGNED, WHO STATED THE INFORMATION ON THIS APPLICATION TO BE TRUE AND CERTIFIED THE FOLLOWING:

"I HEREBY CERTIFY THAT I AM THE OWNER FOR THE PURPOSE OF THIS APPLICATION; ALL INFORMATION SUBMITTED HEREIN IS TRUE AND CORRECT; AND THE APPLICATION FEE OF \$ \_\_\_\_\_ TO COVER THE COST OF THIS APPLICATION, HAS BEEN PAID TO THE CITY OF ROCKWALL ON THIS THE \_\_\_\_\_ DAY OF \_\_\_\_\_, 20\_\_\_\_. BY SIGNING THIS APPLICATION, I AGREE THAT THE CITY OF ROCKWALL (I.E. "CITY") IS AUTHORIZED AND PERMITTED TO PROVIDE INFORMATION CONTAINED WITHIN THIS APPLICATION TO THE PUBLIC. THE CITY IS ALSO AUTHORIZED AND PERMITTED TO REPRODUCE ANY COPYRIGHTED INFORMATION SUBMITTED IN CONJUNCTION WITH THIS APPLICATION, IF SUCH REPRODUCTION IS ASSOCIATED OR IN RESPONSE TO A REQUEST FOR PUBLIC INFORMATION."

GIVEN UNDER MY HAND AND SEAL OF OFFICE ON THIS THE \_\_\_\_\_ DAY OF \_\_\_\_\_, 20\_\_\_\_.

OWNER'S SIGNATURE \_\_\_\_\_

NOTARY PUBLIC IN AND FOR THE STATE OF TEXAS \_\_\_\_\_

MY COMMISSION EXPIRES \_\_\_\_\_





MIS2023-004: Exception to the Fence Material Requirements



Case Location Map = 



# City of Rockwall

Planning & Zoning Department  
385 S. Goliad Street  
Rockwall, Texas 75087  
(P): (972) 771-7745  
(W): www.rockwall.com

The City of Rockwall GIS maps are continually under development and therefore subject to change without notice. While we endeavor to provide timely and accurate information, we make no guarantees. The City of Rockwall makes no warranty, express or implied, including warranties of merchantability and fitness for a particular purpose. Use of the information is the sole responsibility of the user.





[\(855\) 691-0656](tel:8556910656)

**Trex** Fencing SRF

[FENCING](#)

[GATES](#)

[SPECS & DRAWINGS](#)

[GALLERY](#)

[CONTACT](#)

[FIND A CONTRACTOR](#)

[GET PRICING](#)

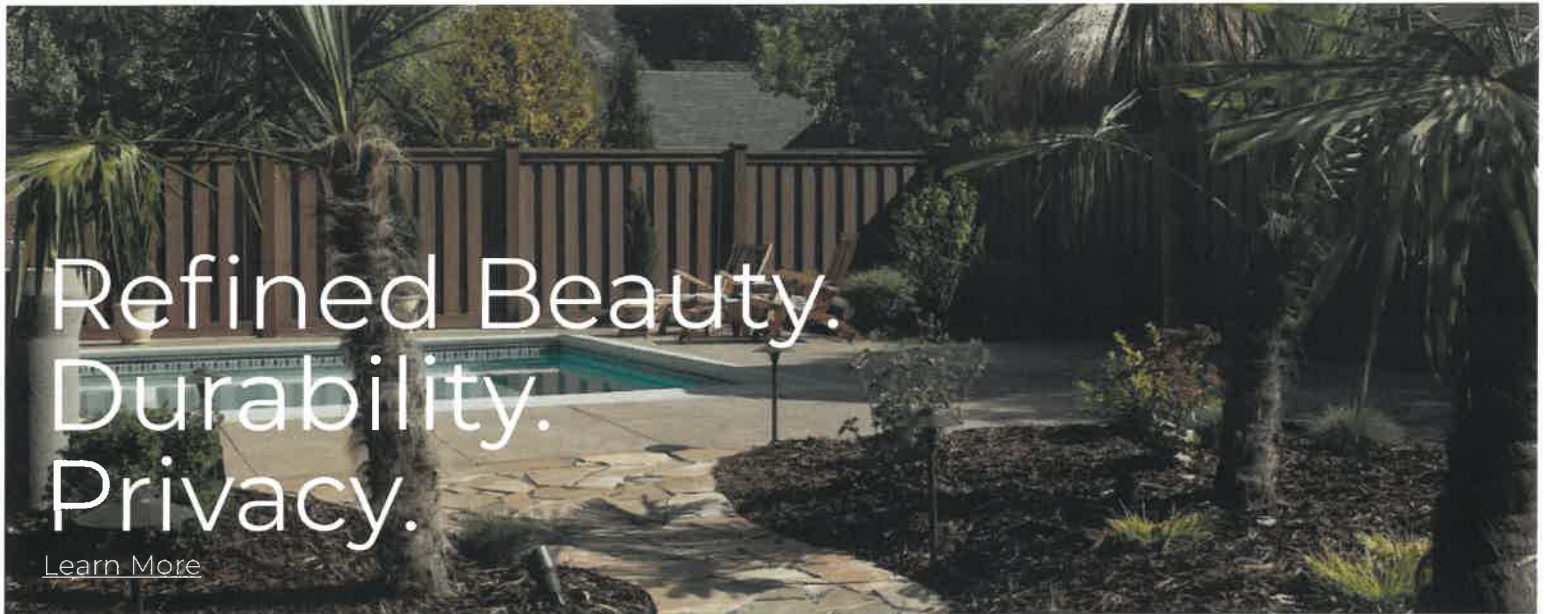

Refined Beauty.  
Durability.  
Privacy.

[Learn More](#)

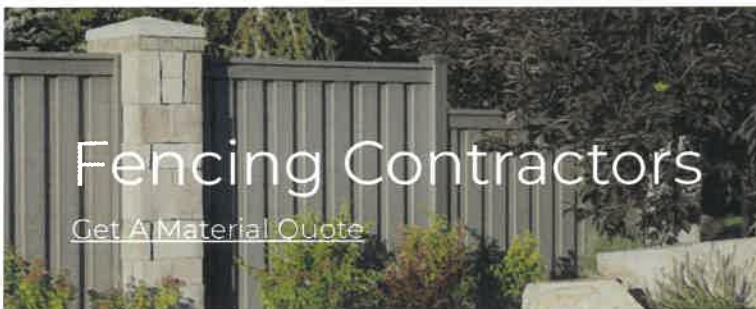

Fencing Contractors

[Get A Material Quote](#)



Homeowners

[Find a Contractor](#)

## Trex Composite Fencing & Gates

Trex Composite Fencing provides a beautiful, unique, low-maintenance alternative to wood and vinyl fences. Since 1996 Trex has invented, defined and perfected the composite deck category, becoming the world's largest manufacturer of wood-alternative decking products. Never content to settle, we continue to make strides in outdoor engineering, melding innovation with environmental responsibility and beautiful form with powerful function. Leveraging our success with decking led to the inclusion of other compatible products. Primary among them were composite fence panels, a unique and innovative application of material that had already proven its value. Blending unique design with precision and durability, Trex fence panels can be trusted to enrich your yard for years to come.

## Fencing Styles



Trex Seclusions



Trex Horizontal



Trex Horizons



[VIEW GALLERY](#)

## Why Trex?

### Recycled Wood —

Reclaimed wood that would otherwise end up in a landfill finds its way into Trex high-performance composite materials. Composite wood fencing offers not just natural appeal, but durability and low maintenance. By using reclaimed sawdust, we never have had to cut down a tree to make our products. Ever.

### Recycled Plastic +

### Eco Friendly Manufacturing +

### The Big Picture +



(855) 691-0656

Trex Fencing SRF

[FENCING](#)

[GATES](#)

[SPECS & DRAWINGS](#)

[GALLERY](#)

[CONTACT](#)

[FIND A CONTRACTOR](#)

[GET PRICING](#)

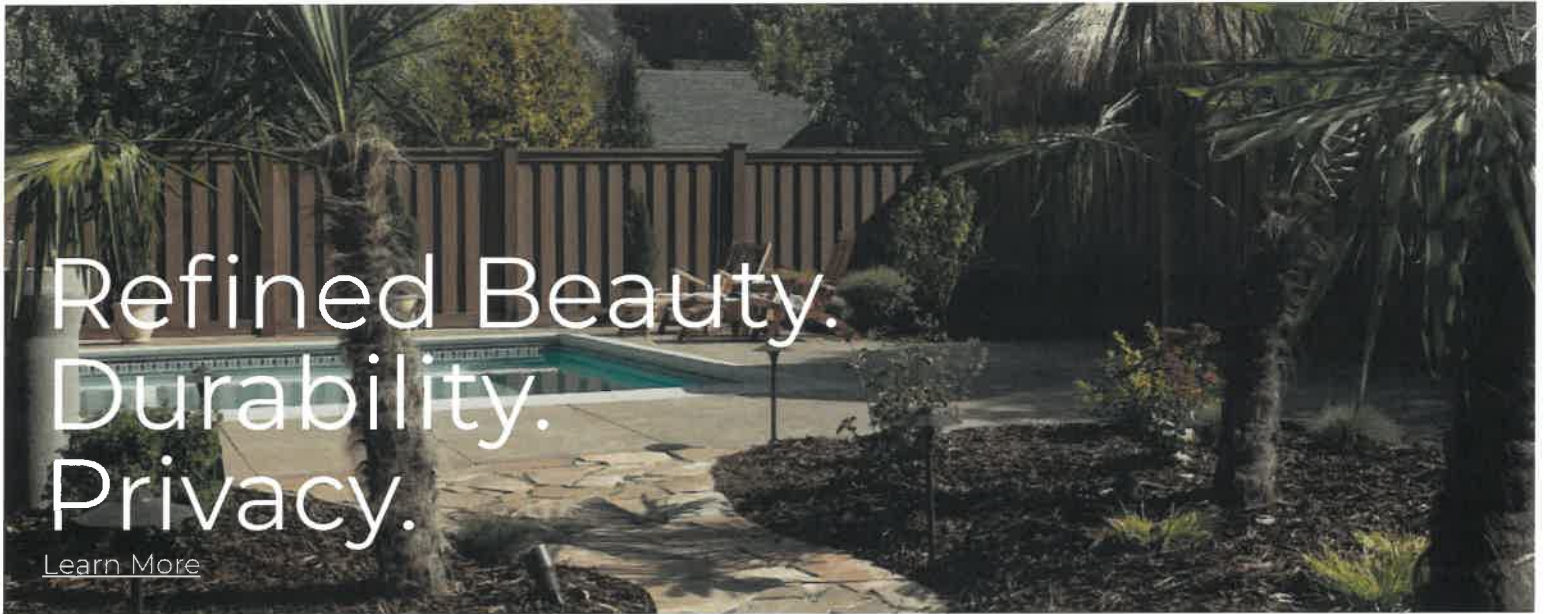

Refined Beauty.  
Durability.  
Privacy.

[Learn More](#)



Fencing Contractors

[Get A Material Quote](#)



Homeowners

[Find a Contractor](#)

## Trex Composite Fencing & Gates

Trex Composite Fencing provides a beautiful, unique, low-maintenance alternative to wood and vinyl fences. Since 1996 Trex has invented, defined and perfected the composite deck category, becoming the world's largest manufacturer of wood-alternative decking products. Never content to settle, we continue to make strides in outdoor engineering, melding innovation with environmental responsibility and beautiful form with powerful function. Leveraging our success with decking led to the inclusion of other compatible products. Primary among them were composite fence panels, a unique and innovative application of material that had already proven its value. Blending unique design with precision and durability, Trex fence panels can be trusted to enrich your yard for years to come.

## Fencing Styles



Trex Seclusions



Trex Horizontal



Trex Horizons

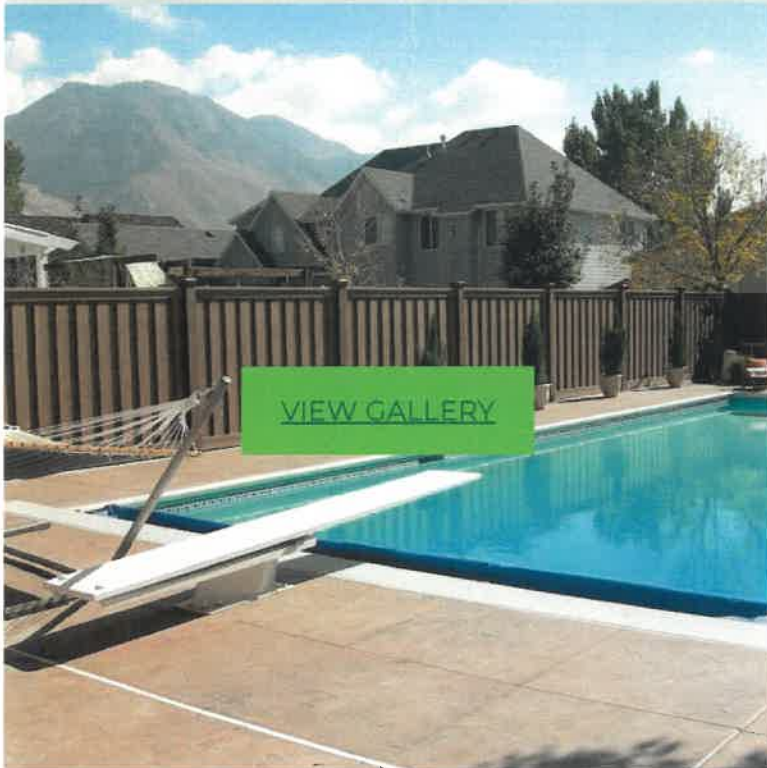

[VIEW GALLERY](#)

## Why Trex?

### Recycled Wood —

Reclaimed wood that would otherwise end up in a landfill finds its way into Trex high-performance composite materials. Composite wood fencing offers not just natural appeal, but durability and low maintenance. By using reclaimed sawdust, we never have had to cut down a tree to make our products. Ever.

### Recycled Plastic +

### Eco Friendly Manufacturing +

### The Big Picture +





## TREX® LIMITED WARRANTY

Trex Company, Inc. (hereinafter "Trex") warrants to the original purchaser ("Purchaser") that, for the period of time set forth in the following sentence, under normal use and service conditions, Trex® products shall be free from material defects in workmanship and materials, and shall not split, splinter, rot or suffer structural damage from termites or fungal decay. The term of such warranty shall be twenty-five (25) years from the date of original purchase for a residential application, and ten (10) years from the date of original purchase for a commercial application. If a defect occurs within the warranty period, Purchaser shall notify Trex in writing and, upon confirmation by an authorized Trex representative of the defect, Trex's sole responsibility shall be, at its option, to either replace the defective item or refund the portion of the purchase price paid by Purchaser for such defective item (not including the cost of its initial installation).

**Notwithstanding the foregoing, (a) the term of the warranty for the LED lights and housing for Trex® DeckLighting™ shall be seven (7) years, the term of the warranty for the LED lights and housing for Trex® LandscapeLighting™ shall be five (5) years, and the term of the warranty for the dimmer, timer and transformer for both shall be three (3) years, in each case provided that a Trex transformer is used (with no warranty on any components if a Trex transformer is not used), and any other parts or accessories shall not be warranted; (b) with respect to hardware for the Trex Surroundings® gate (gate frame, hinges and screws), the term of the warranty shall be five (5) years, (c) with respect to Trex Decorative Balusters, the term of the warranty covering the paint coating shall be ten (10) years, and shall be prorated in the following manner: 100% replacement for the first five (5) years; and 50% replacement for the next five (5) years, and (d) this warranty shall not apply to Trex Elevations® steel deck framing, Trex® Signature™/Reveal® aluminum railing and TrexTrim™ (which each have separate warranties).**

For purposes of this warranty, a "residential application" shall refer to an installation of the Product on an individual residence, and a "commercial application" shall refer to any installation of the Product other than on an individual residence.

**TO THE FULLEST EXTENT PERMITTED UNDER THE LAW, THIS WARRANTY SHALL NOT COVER AND TREX SHALL NOT BE RESPONSIBLE FOR COSTS AND EXPENSES INCURRED WITH RESPECT TO THE REMOVAL OF DEFECTIVE TREX PRODUCTS OR THE INSTALLATION OF REPLACEMENT MATERIALS, INCLUDING BUT NOT LIMITED TO LABOR AND FREIGHT.**

With respect to a residential application, this warranty may be transferred one (1) time, within the five (5) year period beginning from the date of original purchase by the Purchaser, to a subsequent buyer of the property upon which the Trex products were originally installed. With respect to a commercial application, this warranty is freely transferable to subsequent buyers of the property upon which the Trex products were originally installed.

To make a claim under this limited warranty, Purchaser, or the transferee, shall send to Trex, within the warranty period referred to above, a description of the claimed defect and proof of purchase, to the following address:

Trex Company, Inc.  
Customer Relations  
160 Exeter Drive  
Winchester, VA 22603-8605

Trex does not warrant against and is not responsible for any condition attributable to: (1) improper installation of Trex products and/or failure to abide by Trex's installation guidelines, including but not limited to improper gapping; (2) use of Trex products beyond normal use and service conditions, or in an application not recommended by Trex's guidelines and local building codes; (3) movement, distortion, collapse or settling of the ground or the supporting structure on which Trex products are installed; (4) any act of God (such as flooding, hurricane, earthquake, lightning, etc.), environmental condition (such as air pollution, mold, mildew, etc.), staining from foreign substances (such as dirt, grease, oil, etc.), or normal weathering (defined as exposure to sunlight, weather and atmosphere which will cause any colored surface to gradually fade, chalk, or accumulate dirt or stains); (5) variations or changes in color of Trex products; (6) improper handling, storage, abuse or neglect of Trex products by Purchaser, the transferee or third parties; or (7) ordinary wear and tear.

No person or entity is authorized by Trex to make and Trex shall not be bound by any statement or representation as to the quality or performance of Trex products other than as contained in this warranty. This warranty may not be altered or amended except in a written instrument signed by Trex and Purchaser.

**TO THE FULLEST EXTENT PERMITTED UNDER THE LAW, UNDER NO CIRCUMSTANCES WILL TREX BE LIABLE FOR INCIDENTAL OR CONSEQUENTIAL DAMAGES, WHETHER SUCH DAMAGES ARE SOUGHT IN CONTRACT, IN TORT (INCLUDING BUT NOT LIMITED TO NEGLIGENCE AND STRICT LIABILITY) OR OTHERWISE, AND TREX'S LIABILITY FOR NON-PERSONAL INJURY CLAIMS WITH RESPECT TO DEFECTIVE PRODUCTS SHALL IN NO EVENT EXCEED THE REPLACEMENT OF SUCH PRODUCTS OR REFUND OF THE PURCHASE PRICE, AS DESCRIBED ABOVE.**

Some States or Provinces do not allow the exclusion or limitation of incidental or consequential damages, so the above limitation or exclusion may not apply to you. This warranty gives you specific legal rights, and you may also have other rights that vary from State to State or Province to Province.

Copyright © 2018 Trex Company, Inc.



## TREX® LIMITED WARRANTY

Trex Company, Inc. (hereinafter "Trex") warrants to the original purchaser ("Purchaser") that, for the period of time set forth in the following sentence, under normal use and service conditions, Trex® products shall be free from material defects in workmanship and materials, and shall not split, splinter, rot or suffer structural damage from termites or fungal decay. The term of such warranty shall be twenty-five (25) years from the date of original purchase for a residential application, and ten (10) years from the date of original purchase for a commercial application. If a defect occurs within the warranty period, Purchaser shall notify Trex in writing and, upon confirmation by an authorized Trex representative of the defect, Trex's sole responsibility shall be, at its option, to either replace the defective item or refund the portion of the purchase price paid by Purchaser for such defective item (not including the cost of its initial installation).

**Notwithstanding the foregoing, (a) the term of the warranty for the LED lights and housing for Trex® DeckLighting™ shall be seven (7) years, the term of the warranty for the LED lights and housing for Trex® LandscapeLighting™ shall be five (5) years, and the term of the warranty for the dimmer, timer and transformer for both shall be three (3) years, in each case provided that a Trex transformer is used (with no warranty on any components if a Trex transformer is not used), and any other parts or accessories shall not be warranted; (b) with respect to hardware for the Trex Surroundings® gate (gate frame, hinges and screws), the term of the warranty shall be five (5) years, (c) with respect to Trex Decorative Balusters, the term of the warranty covering the paint coating shall be ten (10) years, and shall be prorated in the following manner: 100% replacement for the first five (5) years; and 50% replacement for the next five (5) years, and (d) this warranty shall not apply to Trex Elevations® steel deck framing, Trex® Signature™/Reveal® aluminum railing and TrexTrim™ (which each have separate warranties).**

For purposes of this warranty, a "residential application" shall refer to an installation of the Product on an individual residence, and a "commercial application" shall refer to any installation of the Product other than on an individual residence.

**TO THE FULLEST EXTENT PERMITTED UNDER THE LAW, THIS WARRANTY SHALL NOT COVER AND TREX SHALL NOT BE RESPONSIBLE FOR COSTS AND EXPENSES INCURRED WITH RESPECT TO THE REMOVAL OF DEFECTIVE TREX PRODUCTS OR THE INSTALLATION OF REPLACEMENT MATERIALS, INCLUDING BUT NOT LIMITED TO LABOR AND FREIGHT.**

With respect to a residential application, this warranty may be transferred one (1) time, within the five (5) year period beginning from the date of original purchase by the Purchaser, to a subsequent buyer of the property upon which the Trex products were originally installed. With respect to a commercial application, this warranty is freely transferable to subsequent buyers of the property upon which the Trex products were originally installed.

To make a claim under this limited warranty, Purchaser, or the transferee, shall send to Trex, within the warranty period referred to above, a description of the claimed defect and proof of purchase, to the following address:

Trex Company, Inc.  
Customer Relations  
160 Exeter Drive  
Winchester, VA 22603-8605

Trex does not warrant against and is not responsible for any condition attributable to: (1) improper installation of Trex products and/or failure to abide by Trex's installation guidelines, including but not limited to improper gapping; (2) use of Trex products beyond normal use and service conditions, or in an application not recommended by Trex's guidelines and local building codes; (3) movement, distortion, collapse or settling of the ground or the supporting structure on which Trex products are installed; (4) any act of God (such as flooding, hurricane, earthquake, lightning, etc.), environmental condition (such as air pollution, mold, mildew, etc.), staining from foreign substances (such as dirt, grease, oil, etc.), or normal weathering (defined as exposure to sunlight, weather and atmosphere which will cause any colored surface to gradually fade, chalk, or accumulate dirt or stains); (5) variations or changes in color of Trex products; (6) improper handling, storage, abuse or neglect of Trex products by Purchaser, the transferee or third parties; or (7) ordinary wear and tear.

No person or entity is authorized by Trex to make and Trex shall not be bound by any statement or representation as to the quality or performance of Trex products other than as contained in this warranty. This warranty may not be altered or amended except in a written instrument signed by Trex and Purchaser.

**TO THE FULLEST EXTENT PERMITTED UNDER THE LAW, UNDER NO CIRCUMSTANCES WILL TREX BE LIABLE FOR INCIDENTAL OR CONSEQUENTIAL DAMAGES, WHETHER SUCH DAMAGES ARE SOUGHT IN CONTRACT, IN TORT (INCLUDING BUT NOT LIMITED TO NEGLIGENCE AND STRICT LIABILITY) OR OTHERWISE, AND TREX'S LIABILITY FOR NON-PERSONAL INJURY CLAIMS WITH RESPECT TO DEFECTIVE PRODUCTS SHALL IN NO EVENT EXCEED THE REPLACEMENT OF SUCH PRODUCTS OR REFUND OF THE PURCHASE PRICE, AS DESCRIBED ABOVE.**

Some States or Provinces do not allow the exclusion or limitation of incidental or consequential damages, so the above limitation or exclusion may not apply to you. This warranty gives you specific legal rights, and you may also have other rights that vary from State to State or Province to Province.

Copyright © 2018 Trex Company, Inc.





# Trex® Fencing



REFINED BEAUTY.  
DURABILITY.  
PRIVACY.

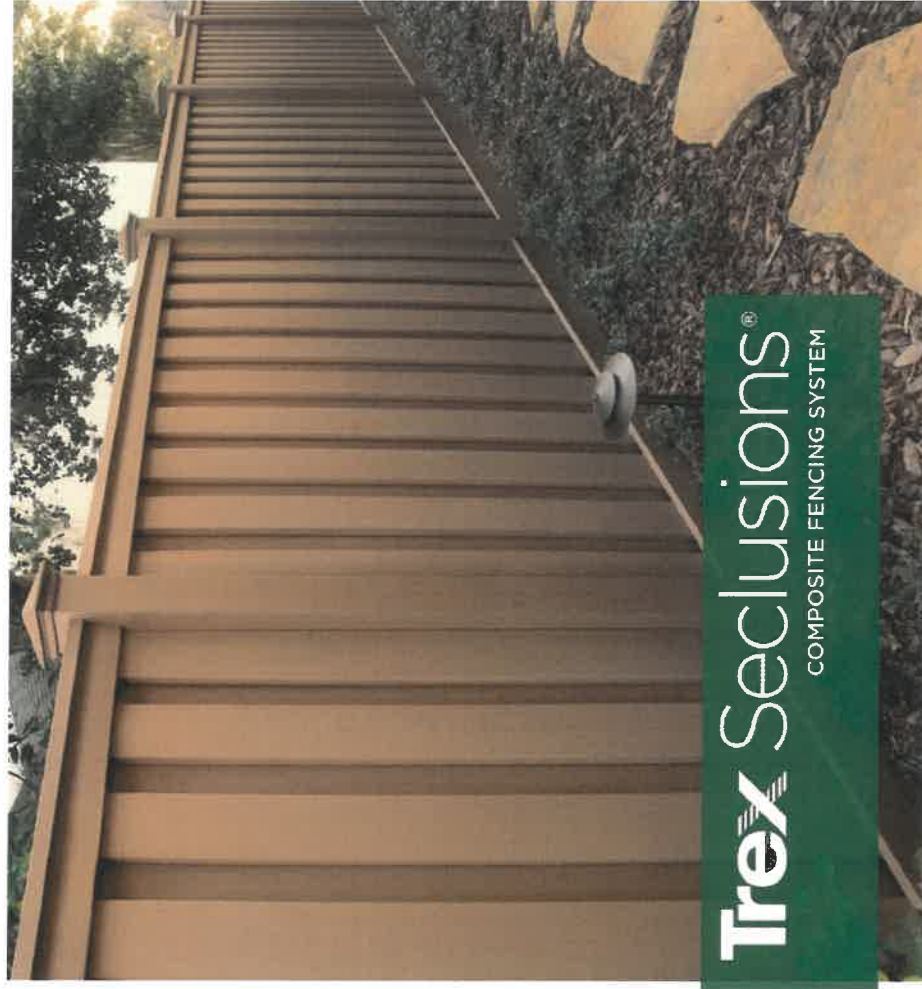

# Trex Seclusions®

COMPOSITE FENCING SYSTEM

**BEAUTY AND PRIVACY FROM EVERY ANGLE**  
Make your backyard a true masterpiece. Frame it with Trex Seclusions®. This composite fencing system offers the perfect backdrop to compliment any backyard paradise. With lasting beauty and low maintenance, it's the perfect fencing solution.



Learn more at  
[trexfencing.com/videos](http://trexfencing.com/videos)

**Trex®**  
OUTDOOR LIVING. DEFINED.  
Visit  
**trexfencing.com**

© 2016 Trex Company, Inc. All rights reserved. Trex®, the Trex logo and Trex Seclusions® are either federally registered trademarks, Trade marks or registered of The Trex Company, Inc. Winchester, Virginia 10221016

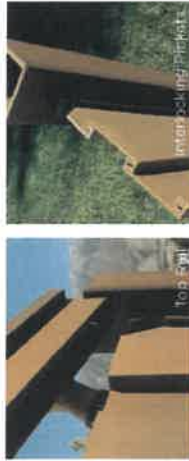

# Trex Fencing



REFINED BEAUTY.  
DURABILITY.  
PRIVACY.

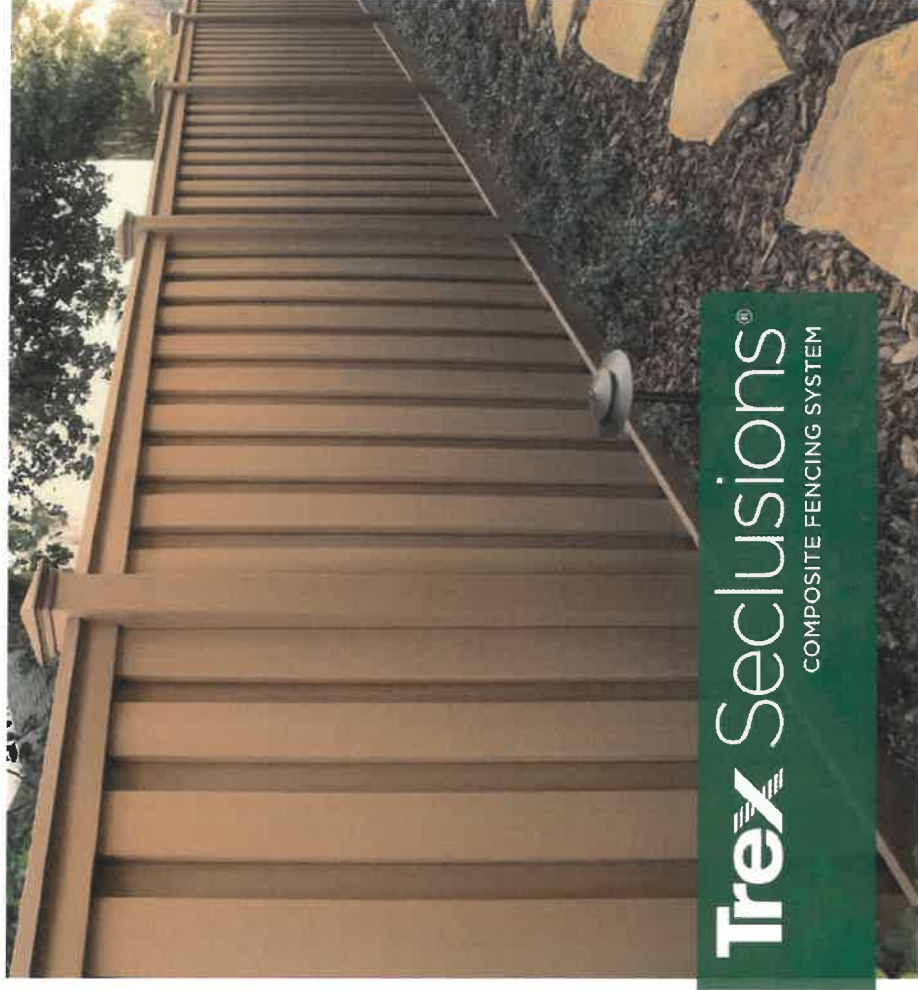

**Trex Seclusions®**  
COMPOSITE FENCING SYSTEM

**BEAUTY AND PRIVACY FROM EVERY ANGLE**  
Make your backyard a true masterpiece. Frame it with Trex Seclusions®. This composite fencing system offers the perfect backdrop to compliment any backyard paradise. With lasting beauty and low maintenance, it's the perfect fencing solution.



Learn more at  
[trexfencing.com/videos](http://trexfencing.com/videos)

**Trex®**

OUTDOOR LIVING, DEFINED.

Visit

[trexfencing.com](http://trexfencing.com)

©2016 Trex Company, Inc. All rights reserved. Trex®, the Trex logo and Trex Seclusions® are either federally registered trademarks, trade marks, or trade dress of The Trex Company, Inc., Winchester, Virginia. 102220115



# Trex® Seclusions® Composite Fencing

ARCHITECTURAL DRAWING:  
TREX SECLUSIONS FENCING  
PROFILE VIEW

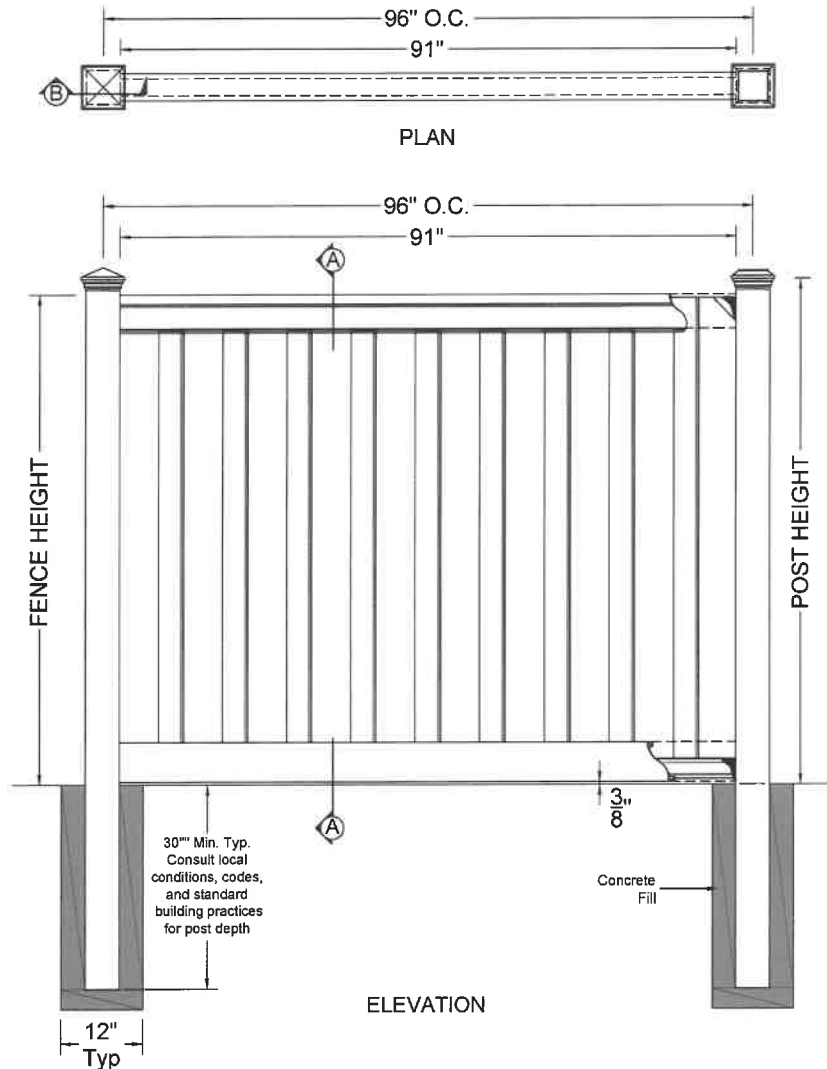

BILL OF MATERIAL FOR A 6'H x 8'W SECTION OF SECLUSIONS FENCINGS		
COMPONENTS	QUANTITY	LENGTH
Post Cap: Pyramid, Flat, or Crown	1	
5" x 5" Post	1	106" *
4" x 4.9" Top Rail	1	91" *
1"x5.75" Interlocking Picket	19	67" *
1" x 5.75" Bottom Rail Cover	2	91" *
Aluminum Bottom Rail	1	90 1/2"
Fence Bracket	4	
1 5/8" (Typ) Exterior Wood Screws	24	

\* Length may vary

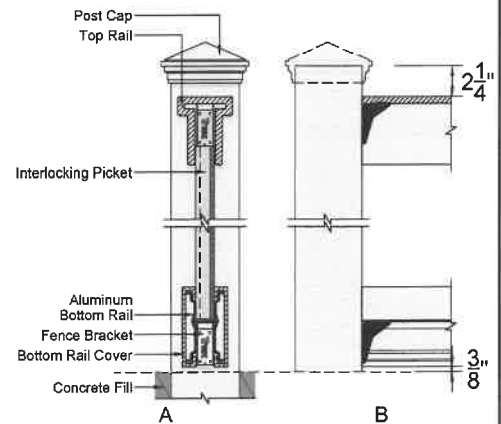

SECTIONS

**NOTES:**

1. INSTALLATION TO BE COMPLETED PER MANUFACTURER'S SPECIFICATION.
2. THIS DRAWING IS PROVIDED FOR PLANNING PURPOSES. REFER TO MANUFACTURER'S INSTALLATIONS FOR CONSTRUCTION DETAILS.
3. REFER TO MANUFACTURER'S WEBSITE FOR PRODUCT INFORMATION.
4. DRAWING NOT TO SCALE.

## TREX SECLUSIONS FENCING PROFILE VIEW

160 EXETER DR, WINCHESTER, VA 22603  
1-800-BUY-TREX / WWW.TREXFENCING.COM

# Trex® Seclusions® Composite Fencing

ARCHITECTURAL DRAWING:  
TREX SECLUSIONS FENCING  
PROFILE VIEW

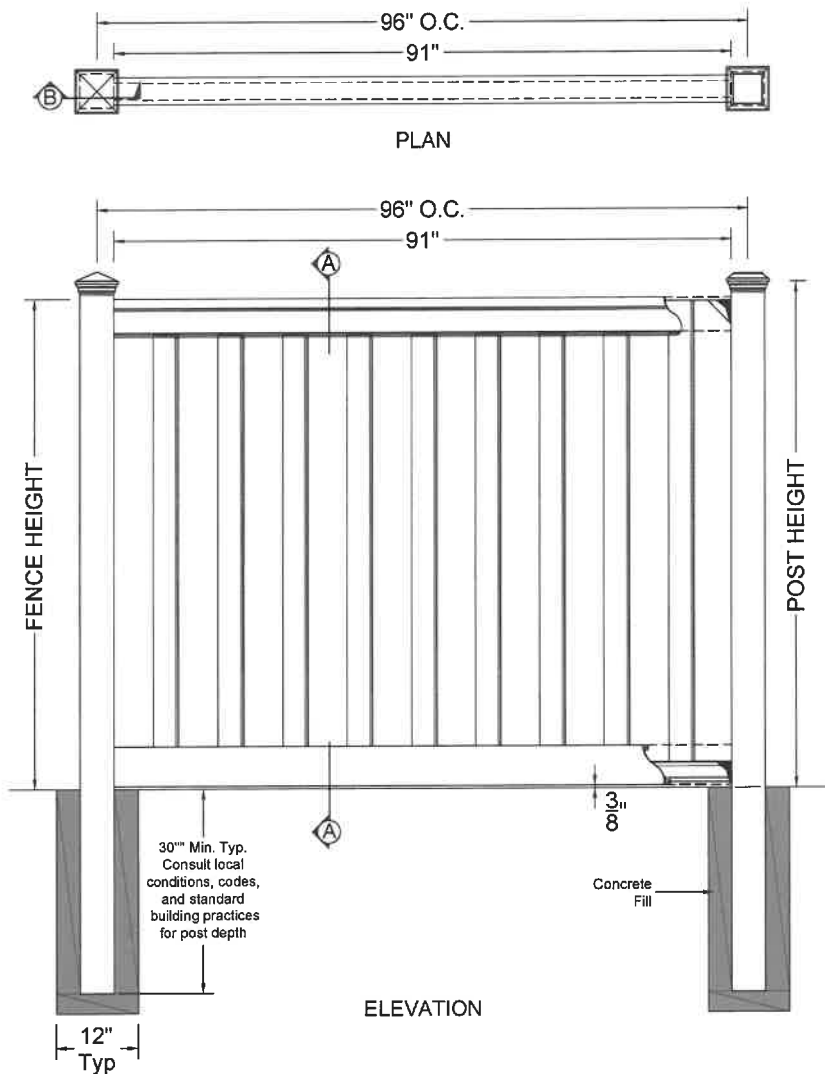

COMPONENTS	QUANTITY	LENGTH
Post Cap: Pyramid, Flat, or Crown	1	
5" x 5" Post	1	106" *
4" x 4.9" Top Rail	1	91" *
1"x5.75" Interlocking Picket	19	67" *
1" x 5.75" Bottom Rail Cover	2	91" *
Aluminum Bottom Rail	1	90 1/2"
Fence Bracket	4	
1 5/8" (Typ) Exterior Wood Screws	24	

\* Length may vary

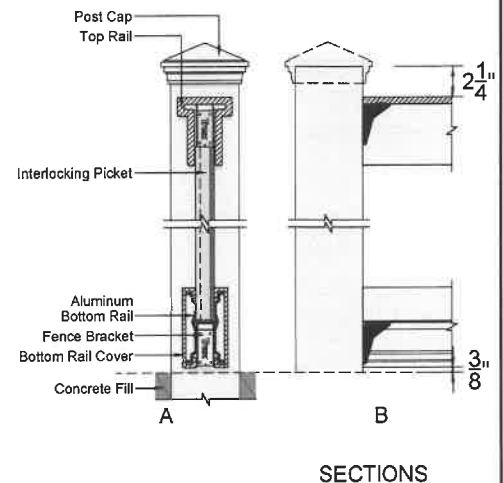

**NOTES:**

1. INSTALLATION TO BE COMPLETED PER MANUFACTURER'S SPECIFICATION.
2. THIS DRAWING IS PROVIDED FOR PLANNING PURPOSES. REFER TO MANUFACTURER'S INSTALLATIONS FOR CONSTRUCTION DETAILS.
3. REFER TO MANUFACTURER'S WEBSITE FOR PRODUCT INFORMATION.
4. DRAWING NOT TO SCALE.

## TREX SECLUSIONS FENCING PROFILE VIEW

160 EXETER DR, WINCHESTER, VA 22603  
1-800-BUY-TREX / WWW.TREXFENCING.COM



# Trex® Seclusions®

## COMPOSITE FENCING SYSTEM

ARCHITECTURAL DRAWING:  
TREX SECLUSIONS FENCING  
6' TALL x 8' WIDE

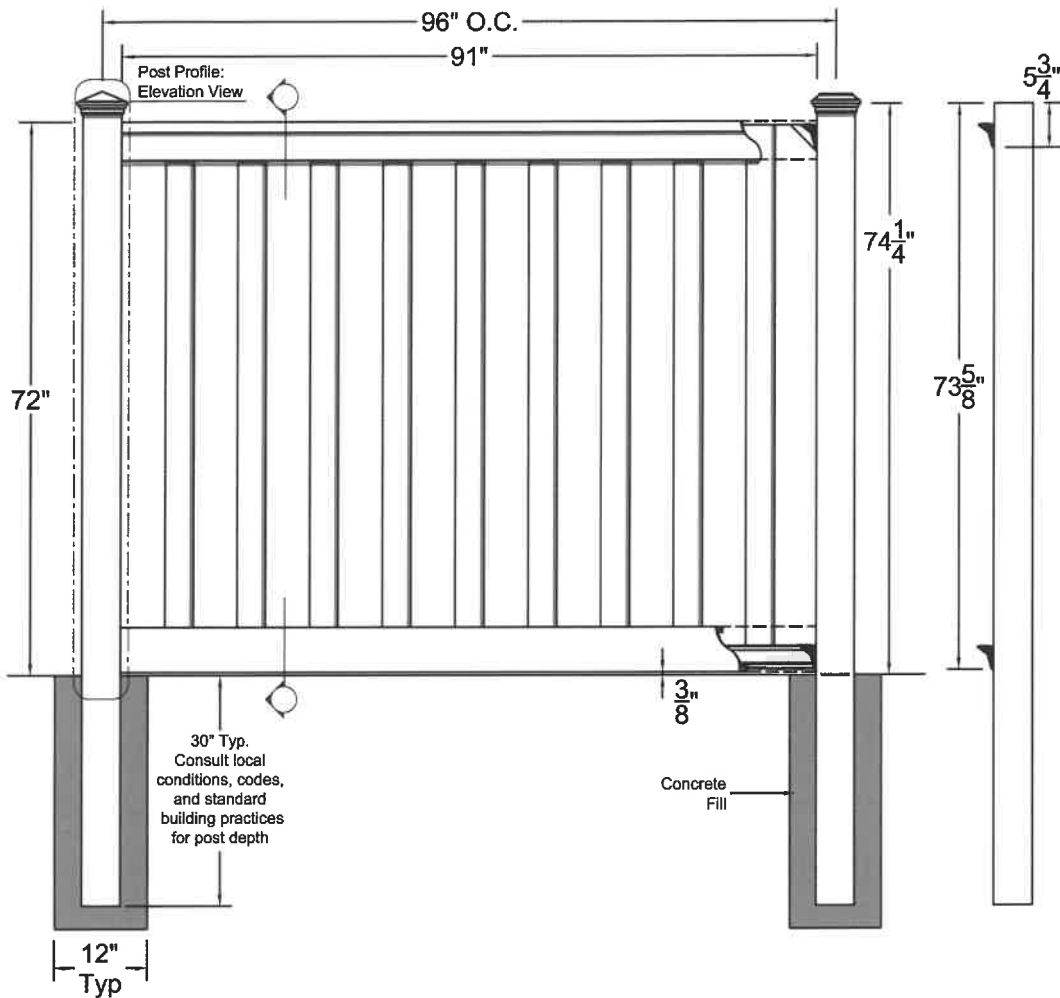

COMPONENTS	QUANTITY	LENGTH
Post Cap: Pyramid, Flat, or Crown	1	
5" x 5" Post	1	108" *
4" x 4.9" Top Rail	1	91" *
1" x 5.75" Interlocking Picket	19	67" *
1" x 5.75" Bottom Rail Cover	2	91" *
Aluminum Bottom Rail	1	90 1/2"
Fence Bracket	4	
1 5/8" (Typ) Exterior Wood Screws	24	

\* Length may vary

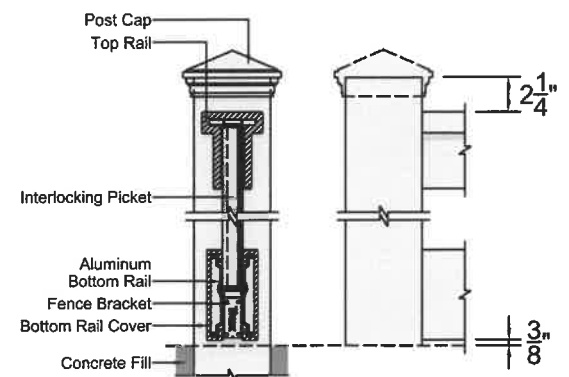

Post Profile: Cut View / Elevation View

### NOTES:

1. INSTALLATION TO BE COMPLETED PER MANUFACTURER'S SPECIFICATION.
2. THIS DRAWING IS PROVIDED FOR PLANNING PURPOSES. REFER TO MANUFACTURER'S INSTALLATIONS FOR CONSTRUCTION DETAILS.
3. REFER TO MANUFACTURER'S WEBSITE FOR PRODUCT INFORMATION.
4. DRAWING NOT TO SCALE.

160 EXETER DR., WINCHESTER VA, 22603

WWW.TREXFENCING.COM

Trex®, the Trex® logo, and Trex Seclusions® are either federally registered trademarks, trademarks or trade dress of Trex Company, Inc., Winchester Virginia or its licensees.  
Copyright © 2019 RIA Designs. All rights reserved.

# Trex® Seclusions®

## COMPOSITE FENCING SYSTEM

ARCHITECTURAL DRAWING:  
TREX SECLUSIONS FENCING  
6' TALL x 8' WIDE

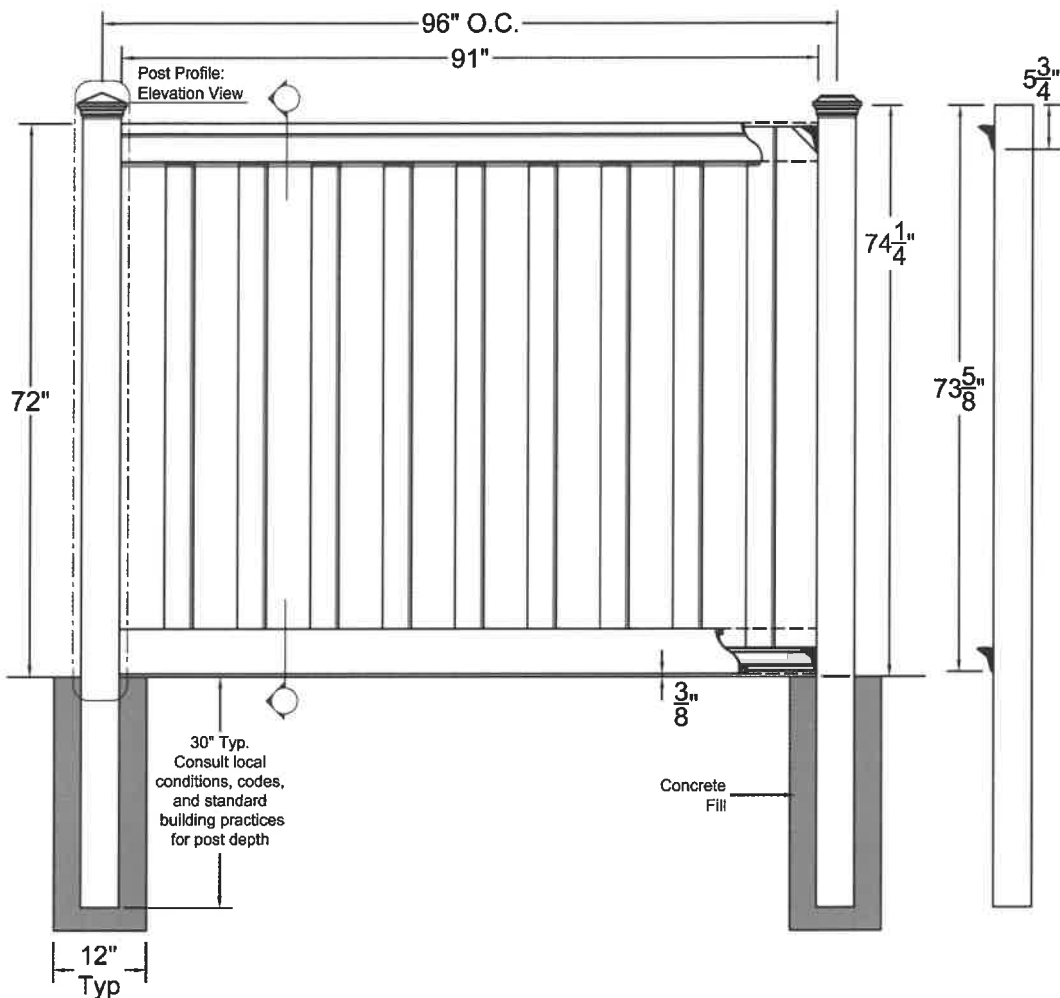

COMPONENTS	QUANTITY	LENGTH
Post Cap: Pyramid, Flat, or Crown	1	
5" x 5" Post	1	108" *
4" x 4.9" Top Rail	1	91" *
1"x5.75" Interlocking Picket	19	67" *
1" x 5.75" Bottom Rail Cover	2	91" *
Aluminum Bottom Rail	1	90 1/2"
Fence Bracket	4	
1 5/8" (Typ) Exterior Wood Screws	24	

\* Length may vary

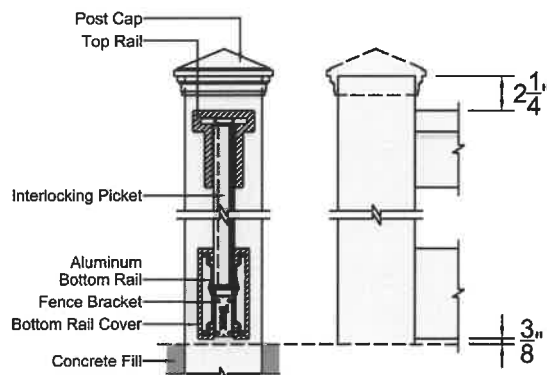

Post Profile: Cut View / Elevation View

### NOTES:

1. INSTALLATION TO BE COMPLETED PER MANUFACTURER'S SPECIFICATION.
2. THIS DRAWING IS PROVIDED FOR PLANNING PURPOSES. REFER TO MANUFACTURER'S INSTALLATIONS FOR CONSTRUCTION DETAILS.
3. REFER TO MANUFACTURER'S WEBSITE FOR PRODUCT INFORMATION.
4. DRAWING NOT TO SCALE.

160 EXETER DR., WINCHESTER VA, 22603

WWW.TREXFENCING.COM

Trex®, the Trex® logo, and Trex Seclusions® are either federally registered trademarks, trademarks or trade dress of Trex Company, Inc., Winchester Virginia or its licensees. Copyright © 2019 R1 A Designs. All rights reserved.

# Trex® Seclusions® Composite Fencing

ARCHITECTURAL DRAWING:  
TREX SECLUSIONS FENCING  
PROFILE VIEW

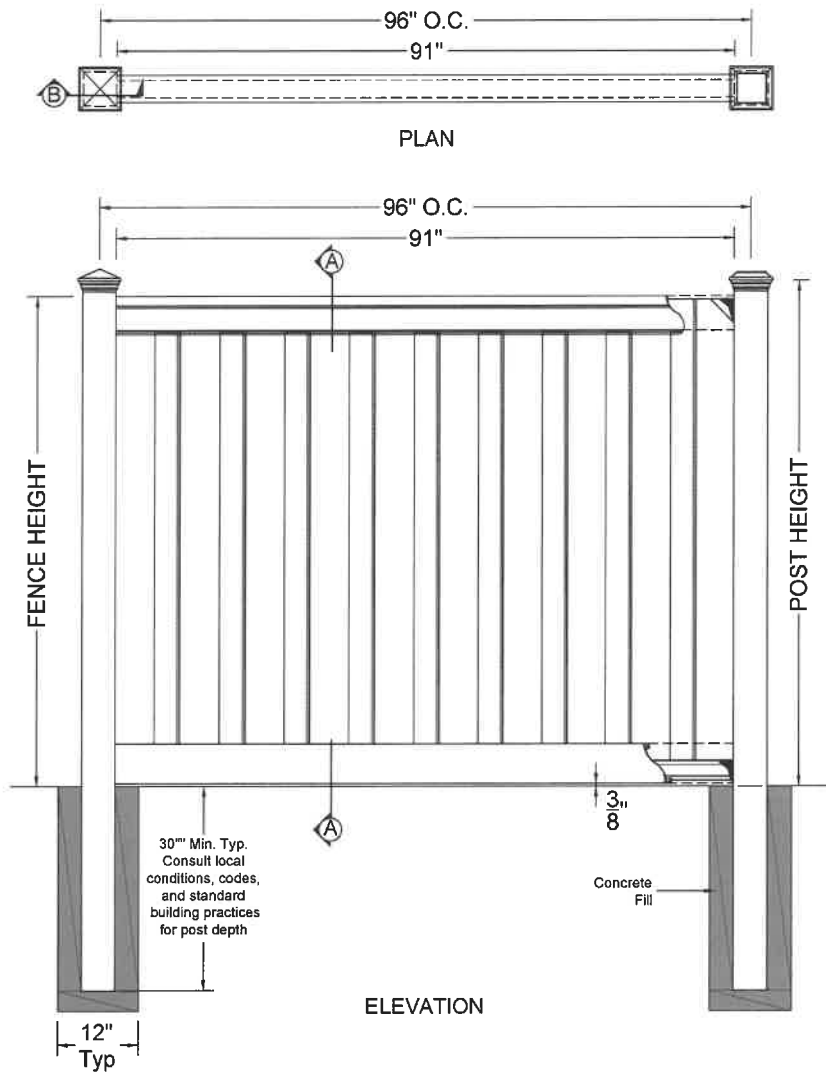

**BILL OF MATERIAL FOR A 6'H x 8'W SECTION OF SECLUSIONS FENCINGS**

COMPONENTS	QUANTITY	LENGTH
Post Cap: Pyramid, Flat, or Crown	1	
5" x 5" Post	1	106" *
4" x 4.9" Top Rail	1	91" *
1"x5.75" Interlocking Picket	19	67" *
1" x 5.75" Bottom Rail Cover	2	91" *
Aluminum Bottom Rail	1	90 1/2"
Fence Bracket	4	
1 5/8" (Typ) Exterior Wood Screws	24	

\* Length may vary

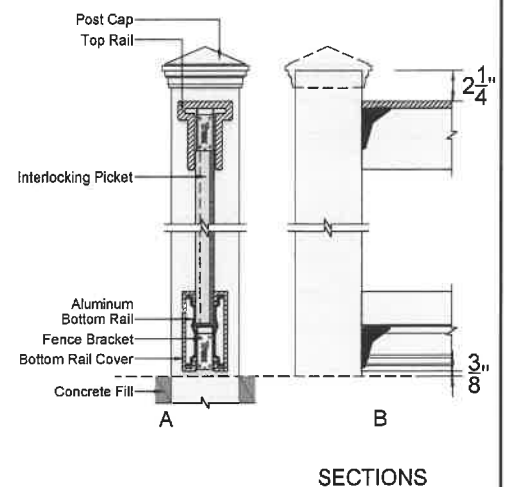

**NOTES:**

1. INSTALLATION TO BE COMPLETED PER MANUFACTURER'S SPECIFICATION.
2. THIS DRAWING IS PROVIDED FOR PLANNING PURPOSES. REFER TO MANUFACTURER'S INSTALLATIONS FOR CONSTRUCTION DETAILS.
3. REFER TO MANUFACTURER'S WEBSITE FOR PRODUCT INFORMATION.
4. DRAWING NOT TO SCALE.

## TREX SECLUSIONS FENCING PROFILE VIEW

160 EXETER DR, WINCHESTER, VA 22603  
1-800-BUY-TREX / WWW.TREXFENCING.COM

# Trex® Seclusions® Composite Fencing

ARCHITECTURAL DRAWING:  
TREX SECLUSIONS FENCING  
PROFILE VIEW

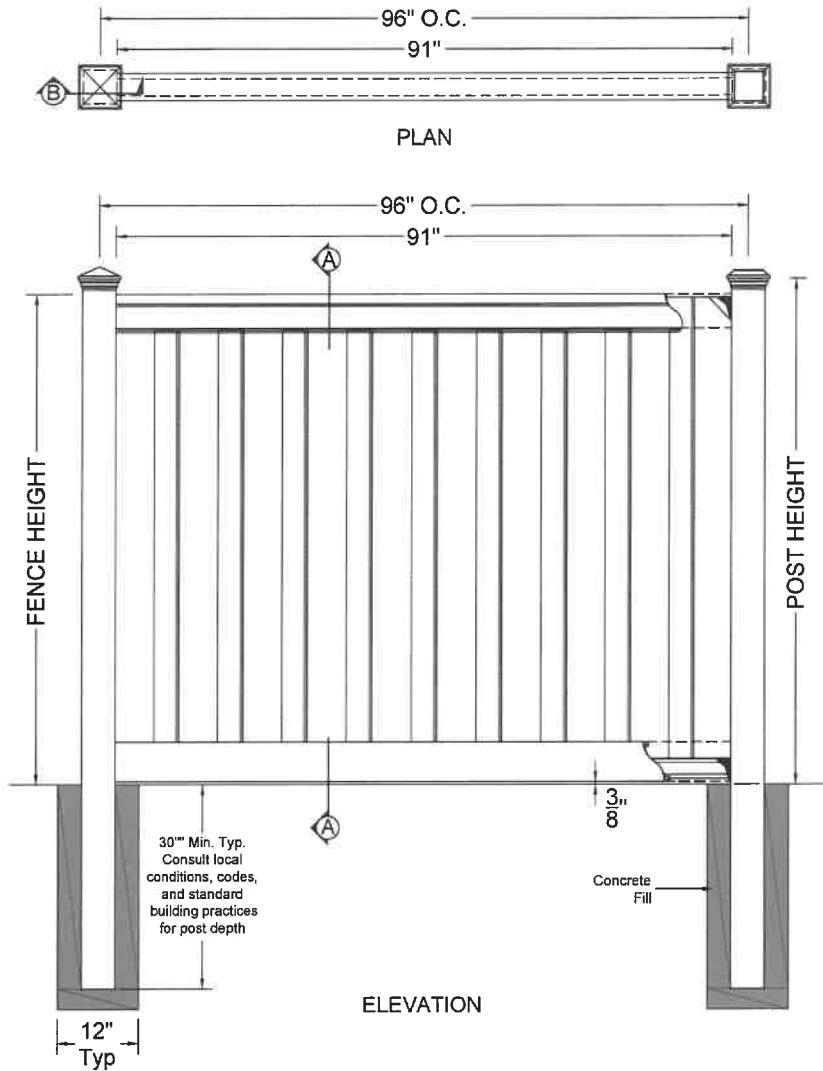

BILL OF MATERIAL FOR A  
6'H x 8'W SECTION OF  
SECLUSIONS FENCINGS

COMPONENTS	QUANTITY	LENGTH
Post Cap: Pyramid, Flat, or Crown	1	
5" x 5" Post	1	106" *
4" x 4.9" Top Rail	1	91" *
1"x5.75" Interlocking Picket	19	67" *
1" x 5.75" Bottom Rail Cover	2	91" *
Aluminum Bottom Rail	1	90 1/2"
Fence Bracket	4	
1 5/8" (Typ) Exterior Wood Screws	24	

\* Length may vary

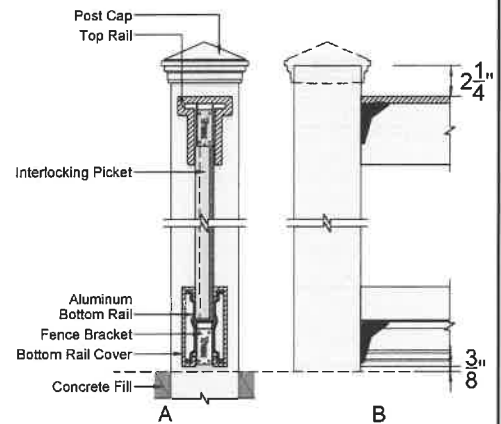

SECTIONS

**NOTES:**

1. INSTALLATION TO BE COMPLETED PER MANUFACTURER'S SPECIFICATION.
2. THIS DRAWING IS PROVIDED FOR PLANNING PURPOSES. REFER TO MANUFACTURER'S INSTALLATIONS FOR CONSTRUCTION DETAILS.
3. REFER TO MANUFACTURER'S WEBSITE FOR PRODUCT INFORMATION.
4. DRAWING NOT TO SCALE.

## TREX SECLUSIONS FENCING PROFILE VIEW

160 EXETER DR, WINCHESTER, VA 22603  
1-800-BUY-TREX / WWW.TREXFENCING.COM





# CITY OF ROCKWALL

## PLANNING AND ZONING COMMISSION MEMORANDUM

### PLANNING AND ZONING DEPARTMENT

385 S. GOLIAD STREET • ROCKWALL, TX 75087

PHONE: (972) 771-7745 • EMAIL: PLANNING@ROCKWALL.COM

---

**TO:** Planning and Zoning Commission  
**FROM:** Bethany Ross, *Planner*  
**DATE:** March 28, 2023  
**SUBJECT:** MIS2023-004; *Exception to the Fence Material Requirements*

---

The applicant, Tim Wolf, is requesting the approval of an exception to the fence material requirements for a backyard fence. The subject property is located on a 0.2498-acre parcel of land (*i.e. Lot 17, Block D, Promenade Harbor Addition*) addressed as 1670 Avonlea Drive. The applicant's *Architectural Drawings* indicate that the backyard fence will be constructed using a composite material (*i.e. Trex Board*) [see *Figure 1*].



**FIGURE 1:** PROPOSED TREX SECLUSIONS COMPOSITE BACK YARD FENCE

According to Article 13, *Definitions*, of the Unified Development Code (UDC), a fence is defined as “(a)ny wall or structure of any material for which the purpose is to provide protection from intrusion, both physical and visual, to prevent escape, mark a boundary, enclose, screen, restrict access to, or decorate any lot, building, or structure.” In addition, Subsection 08.03(B)(1) of Article 08, *Landscape and Fence Standards*, of the Unified Development Code (UDC) states, “All fences being proposed in established residential areas (*i.e. established single-family or duplex subdivision or areas*) -- that are not regulated by a *Planned Development District ordinance* -- shall be architecturally compatible with the design, materials, and colors of the existing fences in the area ... [and] (a)ll solid fencing shall be constructed utilizing standard cedar fencing materials ...” This section goes on to state that the Planning and Zoning Commission may consider alternative materials that are permitted by Subsection 8.02(B) (*e.g. composite fencing*) and/or alternative fence standards on a case-by-case basis. Staff should note that the fence material requirements were written with the intent of creating cohesive fence materials within existing subdivisions. In this case, the applicant is

requesting to replace their existing six (6) foot wood fence with a six (6) foot fence constructed of composite material (*i.e. Trex Board*). The applicant's fence does not appear to create a negative or adverse effect on any of the adjacent properties; however, fence material exceptions are discretionary decisions for the Planning and Zoning Commission. Should the Planning and Zoning Commission have any questions concerning the applicant's request, staff will be available at the meeting on March 28, 2023.

# PROJECT COMMENTS



CITY OF ROCKWALL  
385 S. GOLIAD STREET  
ROCKWALL, TEXAS 75087  
PHONE: (972) 771-7700

DATE: 3/24/2023

PROJECT NUMBER: MIS2023-004  
PROJECT NAME: Exception to the Fence Material Requirements  
SITE ADDRESS/LOCATIONS: 1670 AVONLEA DR

CASE CAPTION: Discuss and request by Tim Wolf for the approval of a Miscellaneous Case for an Exception to the residential fence material requirements on a 0.2498-acre parcel of land identified as Lot 17, Block D, Promenade Harbor Addition, City of Rockwall, Rockwall County, Texas, zoned Single-Family 10 (SF-10) District, addressed as 1670 Avonlea Drive, and take any action necessary.

DEPARTMENT	REVIEWER	DATE OF REVIEW	STATUS OF PROJECT
ENGINEERING	Sarah Johnston	03/21/2023	Approved

No Comments

DEPARTMENT	REVIEWER	DATE OF REVIEW	STATUS OF PROJECT
BUILDING	Rusty McDowell	03/24/2023	Approved w/ Comments

03/24/2023: 1. Concerned about heat causing material to warp.  
2. Horizontal installation will not meet pool barrier requirements.

DEPARTMENT	REVIEWER	DATE OF REVIEW	STATUS OF PROJECT
FIRE	Ariana Kistner	03/20/2023	N/A

No Comments

DEPARTMENT	REVIEWER	DATE OF REVIEW	STATUS OF PROJECT
GIS	Lance Singleton	03/17/2023	N/A

No Comments

DEPARTMENT	REVIEWER	DATE OF REVIEW	STATUS OF PROJECT
POLICE	Chris Cleveland	03/17/2023	Approved

No Comments

DEPARTMENT	REVIEWER	DATE OF REVIEW	STATUS OF PROJECT
PARKS	Travis Sales	03/20/2023	Approved w/ Comments

03/20/2023: Informational only,

Trex can warp in the Texas Summers if there are long runs without adequate support.

DEPARTMENT	REVIEWER	DATE OF REVIEW	STATUS OF PROJECT
------------	----------	----------------	-------------------

03/24/2023: MIS2023-004: Exception to the Fence Material Requirements

Please address the following comments (M= Mandatory Comments; I = Informational Comments)

I.1 This is a request by Tim Wolf for the approval of a Miscellaneous Case for an Exception to the residential fence material requirements on a 0.2498-acre parcel of land identified as Lot 17, Block D, Promenade Harbor Addition, City of Rockwall, Rockwall County, Texas, zoned Single-Family 10 (SF-10) District, addressed as 1670 Avonlea Drive.

I.2 For questions or comments concerning this case please contact Bethany Ross in the Planning Department at (972) 772-6488 or email [bross@rockwall.com](mailto:bross@rockwall.com).

I.3 Subsection 08.03 (B)(1) & (3), Fence Standards for Existing and Infill Single-Family and Duplex Properties, Article 08, Landscape and Fence Standards, of the Unified Development Code (UDC):

(B) Fence Standards for Existing and Infill Single-Family and Duplex Properties. All fences being proposed in established residential areas (i.e. established single-family or duplex subdivision or areas) -- that are not regulated by a Planned Development District ordinance -- shall be architecturally compatible with the design, materials, and colors of the existing fences in the area; however, the following minimum standards shall apply to all fences requiring a fence permit in these areas:

(1) Solid Fencing. All solid fencing shall be constructed utilizing standard cedar fencing materials (spruce fencing is prohibited) that are a minimum of ½-inch or greater in thickness. Fences shall be constructed a minimum of six (6) feet in height and a maximum of eight (8) feet in height. Posts, fasteners, and bolts shall be formed from hot dipped galvanized or stainless steel. All cedar pickets shall be placed on the public side and all posts and/or framing shall be placed on the private side when adjacent to a public street (excluding alleyway), open space, Public Park, and/or neighboring properties. Painting a fence with oil or latex based paint shall be prohibited.

(3) Special Exceptions. The Planning and Zoning Commission may consider alternative materials that are permitted by Subsection 8.02(B) (e.g. composite fencing) and/or alternative fence standards on a case-by-case basis.

I.4 According to Article 13, Definitions, of the Unified Development Code (UDC), a fence is defined as "(a)ny wall or structure of any material for which the purpose is to provide protection from intrusion, both physical and visual, to prevent escape, mark a boundary, enclose, screen, restrict access to, or decorate any lot, building, or structure."

I.5 In this case, the applicant is requesting a 6-foot Trex Seclusions Composite Fence for the backyard to replace the existing 6-foot wood fence.

I.6 Please note the scheduled meeting for this case:

1) Planning & Zoning Work Session meeting will be held on March 28, 2023 at 6pm in the council chambers at City Hall.

I.7 Staff recommends that a representative be present for the meetings as scheduled above to answer any questions the Commission or Council may have regarding your request. All meetings will be held in person, in the City's Council Chambers, and are scheduled to begin at 6:00 p.m.





# DEVELOPMENT APPLICATION

City of Rockwall  
Planning and Zoning Department  
385 S. Goliad Street  
Rockwall, Texas 75087

### STAFF USE ONLY

PLANNING & ZONING CASE NO. **MIS 2023 - 004**

**NOTE: THE APPLICATION IS NOT CONSIDERED ACCEPTED BY THE CITY UNTIL THE PLANNING DIRECTOR AND CITY ENGINEER HAVE SIGNED BELOW.**

DIRECTOR OF PLANNING: \_\_\_\_\_

CITY ENGINEER: \_\_\_\_\_

PLEASE CHECK THE APPROPRIATE BOX BELOW TO INDICATE THE TYPE OF DEVELOPMENT REQUEST [SELECT ONLY ONE BOX]:

#### PLATTING APPLICATION FEES:

- MASTER PLAT (\$100.00 + \$15.00 ACRE) <sup>1</sup>
- PRELIMINARY PLAT (\$200.00 + \$15.00 ACRE) <sup>1</sup>
- FINAL PLAT (\$300.00 + \$20.00 ACRE) <sup>1</sup>
- REPLAT (\$300.00 + \$20.00 ACRE) <sup>1</sup>
- AMENDING OR MINOR PLAT (\$150.00)
- PLAT REINSTATEMENT REQUEST (\$100.00)

#### SITE PLAN APPLICATION FEES:

- SITE PLAN (\$250.00 + \$20.00 ACRE) <sup>1</sup>
- AMENDED SITE PLAN/ELEVATIONS/LANDSCAPING PLAN (\$100.00)

#### ZONING APPLICATION FEES:

- ZONING CHANGE (\$200.00 + \$15.00 ACRE) <sup>1</sup>
- SPECIFIC USE PERMIT (\$200.00 + \$15.00 ACRE) <sup>1&2</sup>
- PD DEVELOPMENT PLANS (\$200.00 + \$15.00 ACRE) <sup>1</sup>

#### OTHER APPLICATION FEES:

- TREE REMOVAL (\$75.00)
- VARIANCE REQUEST/SPECIAL EXCEPTIONS (\$100.00) <sup>2</sup>

#### NOTES:

<sup>1</sup>: IN DETERMINING THE FEE, PLEASE USE THE EXACT ACREAGE WHEN MULTIPLYING BY THE PER ACRE AMOUNT. FOR REQUESTS ON LESS THAN ONE ACRE, ROUND UP TO ONE (1) ACRE.  
<sup>2</sup>: A **\$1,000.00** FEE WILL BE ADDED TO THE APPLICATION FEE FOR ANY REQUEST THAT INVOLVES CONSTRUCTION WITHOUT OR NOT IN COMPLIANCE TO AN APPROVED BUILDING PERMIT.

### PROPERTY INFORMATION [PLEASE PRINT]

ADDRESS **1670 Avonlea Dr**

SUBDIVISION \_\_\_\_\_ LOT \_\_\_\_\_ BLOCK \_\_\_\_\_

GENERAL LOCATION \_\_\_\_\_

### ZONING, SITE PLAN AND PLATTING INFORMATION [PLEASE PRINT]

CURRENT ZONING \_\_\_\_\_ CURRENT USE \_\_\_\_\_

PROPOSED ZONING \_\_\_\_\_ PROPOSED USE \_\_\_\_\_

ACREAGE \_\_\_\_\_ LOTS [CURRENT] \_\_\_\_\_ LOTS [PROPOSED] \_\_\_\_\_

**SITE PLANS AND PLATS:** BY CHECKING THIS BOX YOU ACKNOWLEDGE THAT DUE TO THE PASSAGE OF HB3167 THE CITY NO LONGER HAS FLEXIBILITY WITH REGARD TO ITS APPROVAL PROCESS, AND FAILURE TO ADDRESS ANY OF STAFF'S COMMENTS BY THE DATE PROVIDED ON THE DEVELOPMENT CALENDAR WILL RESULT IN THE DENIAL OF YOUR CASE.

### OWNER/APPLICANT/AGENT INFORMATION [PLEASE PRINT/CHECK THE PRIMARY CONTACT/ORIGINAL SIGNATURES ARE REQUIRED]

OWNER **Tim Wolf**  APPLICANT \_\_\_\_\_

CONTACT PERSON \_\_\_\_\_ CONTACT PERSON \_\_\_\_\_

ADDRESS **1670 Avonlea Dr** ADDRESS \_\_\_\_\_

CITY, STATE & ZIP **Rockwall TX 75087** CITY, STATE & ZIP \_\_\_\_\_

PHONE **214-662-6100** PHONE \_\_\_\_\_

E-MAIL **t.wolf@rockwalltexas.com** E-MAIL \_\_\_\_\_

### NOTARY VERIFICATION [REQUIRED]

BEFORE ME, THE UNDERSIGNED AUTHORITY, ON THIS DAY PERSONALLY APPEARED \_\_\_\_\_ [OWNER] THE UNDERSIGNED, WHO STATED THE INFORMATION ON THIS APPLICATION TO BE TRUE AND CERTIFIED THE FOLLOWING:

"I HEREBY CERTIFY THAT I AM THE OWNER FOR THE PURPOSE OF THIS APPLICATION; ALL INFORMATION SUBMITTED HEREIN IS TRUE AND CORRECT; AND THE APPLICATION FEE OF \$ \_\_\_\_\_ TO COVER THE COST OF THIS APPLICATION, HAS BEEN PAID TO THE CITY OF ROCKWALL ON THIS THE \_\_\_\_\_ DAY OF \_\_\_\_\_, 20\_\_\_\_. BY SIGNING THIS APPLICATION, I AGREE THAT THE CITY OF ROCKWALL (I.E. "CITY") IS AUTHORIZED AND PERMITTED TO PROVIDE INFORMATION CONTAINED WITHIN THIS APPLICATION TO THE PUBLIC. THE CITY IS ALSO AUTHORIZED AND PERMITTED TO REPRODUCE ANY COPYRIGHTED INFORMATION SUBMITTED IN CONJUNCTION WITH THIS APPLICATION, IF SUCH REPRODUCTION IS ASSOCIATED OR IN RESPONSE TO A REQUEST FOR PUBLIC INFORMATION."

GIVEN UNDER MY HAND AND SEAL OF OFFICE ON THIS THE \_\_\_\_\_ DAY OF \_\_\_\_\_, 20\_\_\_\_.

OWNER'S SIGNATURE \_\_\_\_\_

NOTARY PUBLIC IN AND FOR THE STATE OF TEXAS \_\_\_\_\_

MY COMMISSION EXPIRES \_\_\_\_\_





MIS2023-004: Exception to the Fence Material Requirements



Case Location Map = 



# City of Rockwall

Planning & Zoning Department  
385 S. Goliad Street  
Rockwall, Texas 75087  
(P): (972) 771-7745  
(W): [www.rockwall.com](http://www.rockwall.com)

The City of Rockwall GIS maps are continually under development and therefore subject to change without notice. While we endeavor to provide timely and accurate information, we make no guarantees. The City of Rockwall makes no warranty, express or implied, including warranties of merchantability and fitness for a particular purpose. Use of the information is the sole responsibility of the user.





(855) 691-0656

Trex Fencing SRF

[FENCING](#)

[GATES](#)

[SPECS & DRAWINGS](#)

[GALLERY](#)

[CONTACT](#)

[FIND A CONTRACTOR](#)

[GET PRICING](#)

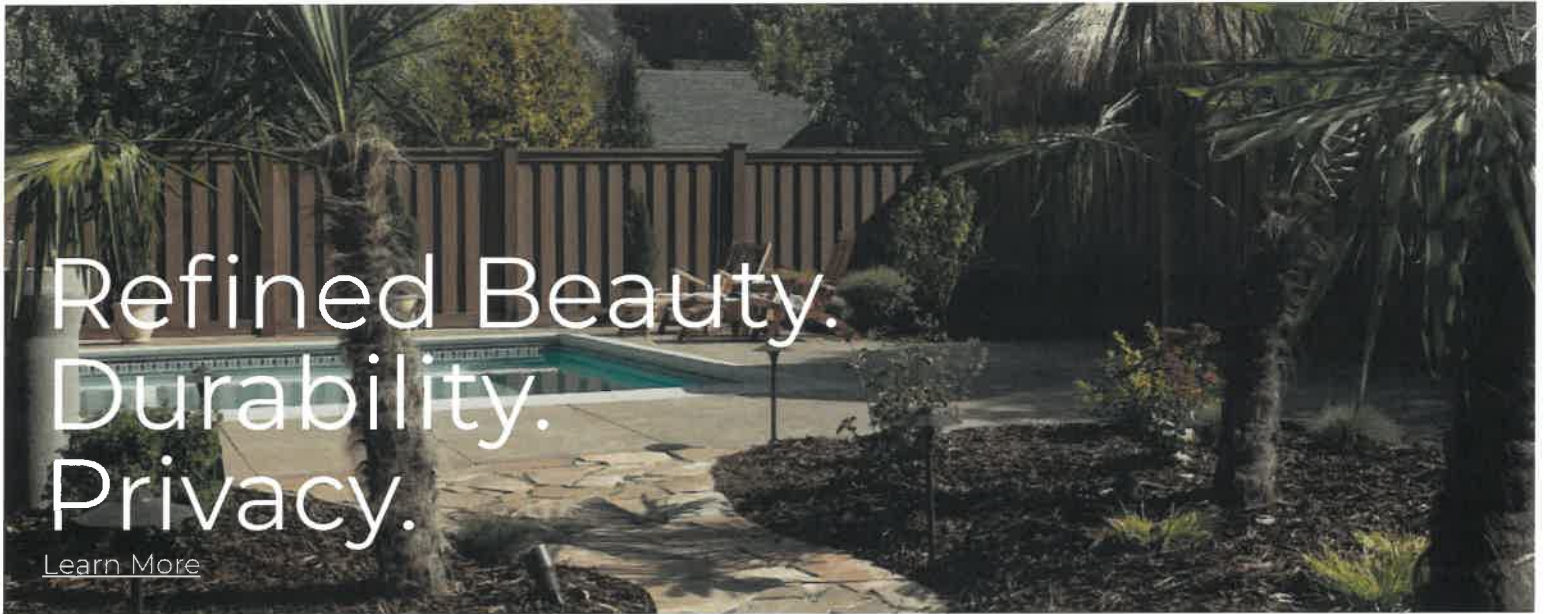

Refined Beauty.  
Durability.  
Privacy.

[Learn More](#)



Fencing Contractors

[Get A Material Quote](#)



Homeowners

[Find a Contractor](#)

## Trex Composite Fencing & Gates

Trex Composite Fencing provides a beautiful, unique, low-maintenance alternative to wood and vinyl fences. Since 1996 Trex has invented, defined and perfected the composite deck category, becoming the world's largest manufacturer of wood-alternative decking products. Never content to settle, we continue to make strides in outdoor engineering, melding innovation with environmental responsibility and beautiful form with powerful function. Leveraging our success with decking led to the inclusion of other compatible products. Primary among them were composite fence panels, a unique and innovative application of material that had already proven its value. Blending unique design with precision and durability, Trex fence panels can be trusted to enrich your yard for years to come.



## Fencing Styles



Trex Seclusions



Trex Horizontal



Trex Horizons

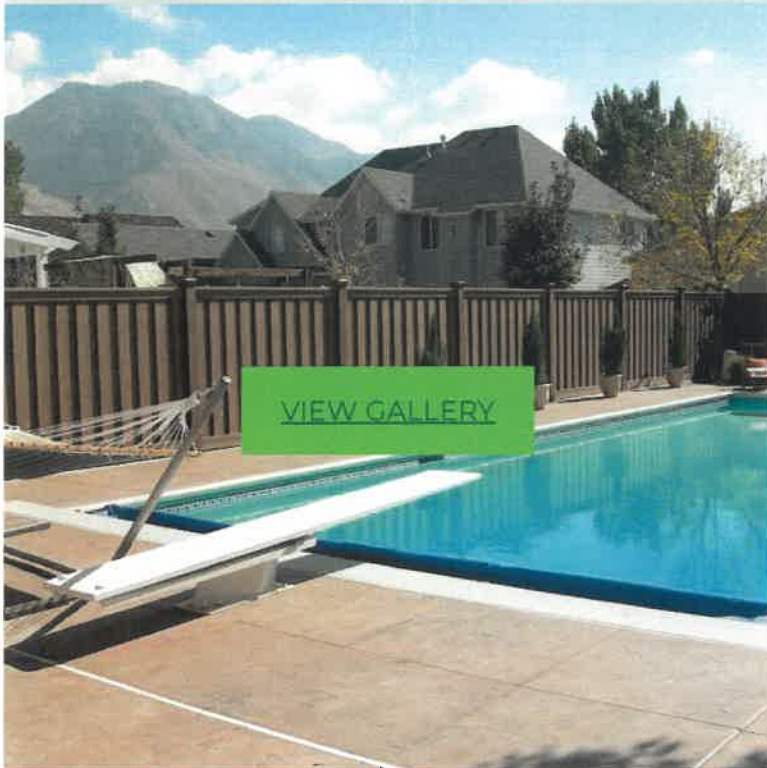

[VIEW GALLERY](#)

## Why Trex?

### Recycled Wood —

Reclaimed wood that would otherwise end up in a landfill finds its way into Trex high-performance composite materials. Composite wood fencing offers not just natural appeal, but durability and low maintenance. By using reclaimed sawdust, we never have had to cut down a tree to make our products. Ever.

### Recycled Plastic +

### Eco Friendly Manufacturing +

### The Big Picture +



## TREX® LIMITED WARRANTY

Trex Company, Inc. (hereinafter "Trex") warrants to the original purchaser ("Purchaser") that, for the period of time set forth in the following sentence, under normal use and service conditions, Trex® products shall be free from material defects in workmanship and materials, and shall not split, splinter, rot or suffer structural damage from termites or fungal decay. The term of such warranty shall be twenty-five (25) years from the date of original purchase for a residential application, and ten (10) years from the date of original purchase for a commercial application. If a defect occurs within the warranty period, Purchaser shall notify Trex in writing and, upon confirmation by an authorized Trex representative of the defect, Trex's sole responsibility shall be, at its option, to either replace the defective item or refund the portion of the purchase price paid by Purchaser for such defective item (not including the cost of its initial installation).

**Notwithstanding the foregoing, (a) the term of the warranty for the LED lights and housing for Trex® DeckLighting™ shall be seven (7) years, the term of the warranty for the LED lights and housing for Trex® LandscapeLighting™ shall be five (5) years, and the term of the warranty for the dimmer, timer and transformer for both shall be three (3) years, in each case provided that a Trex transformer is used (with no warranty on any components if a Trex transformer is not used), and any other parts or accessories shall not be warranted; (b) with respect to hardware for the Trex Surroundings® gate (gate frame, hinges and screws), the term of the warranty shall be five (5) years, (c) with respect to Trex Decorative Balusters, the term of the warranty covering the paint coating shall be ten (10) years, and shall be prorated in the following manner: 100% replacement for the first five (5) years; and 50% replacement for the next five (5) years, and (d) this warranty shall not apply to Trex Elevations® steel deck framing, Trex® Signature™/Reveal® aluminum railing and TrexTrim™ (which each have separate warranties).**

For purposes of this warranty, a "residential application" shall refer to an installation of the Product on an individual residence, and a "commercial application" shall refer to any installation of the Product other than on an individual residence.

**TO THE FULLEST EXTENT PERMITTED UNDER THE LAW, THIS WARRANTY SHALL NOT COVER AND TREX SHALL NOT BE RESPONSIBLE FOR COSTS AND EXPENSES INCURRED WITH RESPECT TO THE REMOVAL OF DEFECTIVE TREX PRODUCTS OR THE INSTALLATION OF REPLACEMENT MATERIALS, INCLUDING BUT NOT LIMITED TO LABOR AND FREIGHT.**

With respect to a residential application, this warranty may be transferred one (1) time, within the five (5) year period beginning from the date of original purchase by the Purchaser, to a subsequent buyer of the property upon which the Trex products were originally installed. With respect to a commercial application, this warranty is freely transferable to subsequent buyers of the property upon which the Trex products were originally installed.

To make a claim under this limited warranty, Purchaser, or the transferee, shall send to Trex, within the warranty period referred to above, a description of the claimed defect and proof of purchase, to the following address:

Trex Company, Inc.  
Customer Relations  
160 Exeter Drive  
Winchester, VA 22603-8605

Trex does not warrant against and is not responsible for any condition attributable to: (1) improper installation of Trex products and/or failure to abide by Trex's installation guidelines, including but not limited to improper gapping; (2) use of Trex products beyond normal use and service conditions, or in an application not recommended by Trex's guidelines and local building codes; (3) movement, distortion, collapse or settling of the ground or the supporting structure on which Trex products are installed; (4) any act of God (such as flooding, hurricane, earthquake, lightning, etc.), environmental condition (such as air pollution, mold, mildew, etc.), staining from foreign substances (such as dirt, grease, oil, etc.), or normal weathering (defined as exposure to sunlight, weather and atmosphere which will cause any colored surface to gradually fade, chalk, or accumulate dirt or stains); (5) variations or changes in color of Trex products; (6) improper handling, storage, abuse or neglect of Trex products by Purchaser, the transferee or third parties; or (7) ordinary wear and tear.

No person or entity is authorized by Trex to make and Trex shall not be bound by any statement or representation as to the quality or performance of Trex products other than as contained in this warranty. This warranty may not be altered or amended except in a written instrument signed by Trex and Purchaser.

**TO THE FULLEST EXTENT PERMITTED UNDER THE LAW, UNDER NO CIRCUMSTANCES WILL TREX BE LIABLE FOR INCIDENTAL OR CONSEQUENTIAL DAMAGES, WHETHER SUCH DAMAGES ARE SOUGHT IN CONTRACT, IN TORT (INCLUDING BUT NOT LIMITED TO NEGLIGENCE AND STRICT LIABILITY) OR OTHERWISE, AND TREX'S LIABILITY FOR NON-PERSONAL INJURY CLAIMS WITH RESPECT TO DEFECTIVE PRODUCTS SHALL IN NO EVENT EXCEED THE REPLACEMENT OF SUCH PRODUCTS OR REFUND OF THE PURCHASE PRICE, AS DESCRIBED ABOVE.**

Some States or Provinces do not allow the exclusion or limitation of incidental or consequential damages, so the above limitation or exclusion may not apply to you. This warranty gives you specific legal rights, and you may also have other rights that vary from State to State or Province to Province.

Copyright © 2018 Trex Company, Inc.





# Trex® Fencing



REFINED BEAUTY.  
DURABILITY.  
PRIVACY.

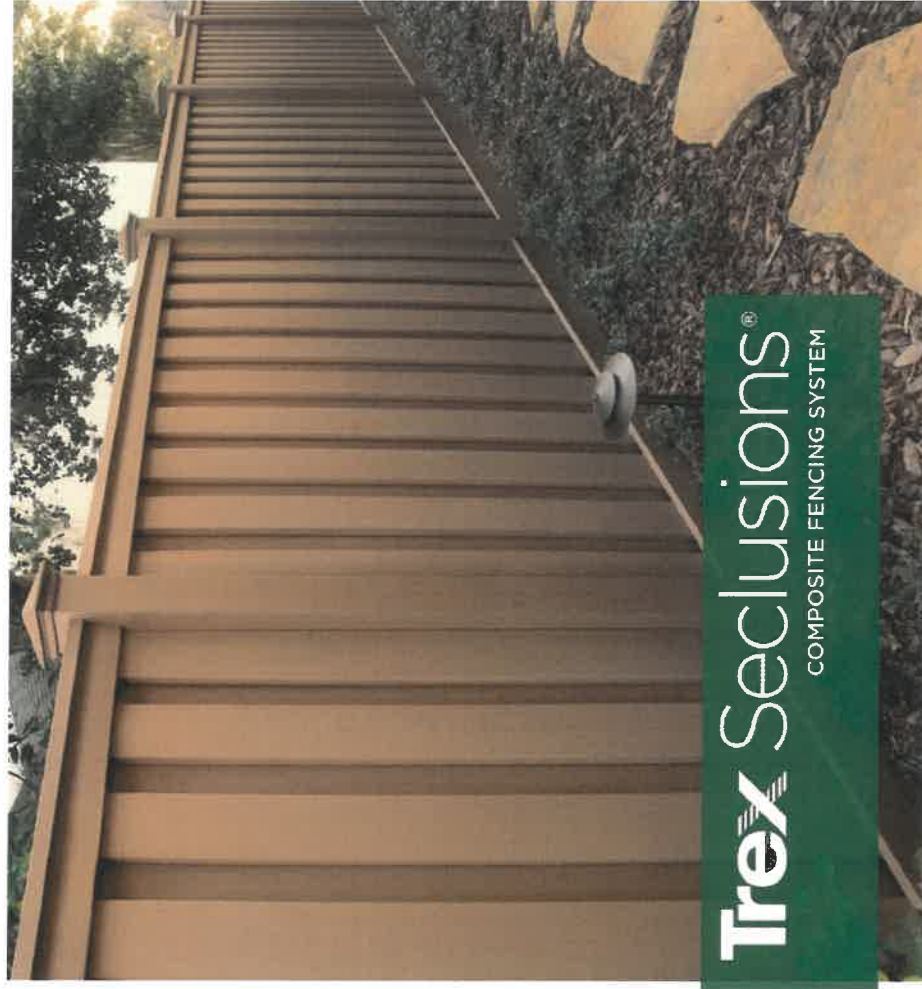

**Trex Seclusions®**  
COMPOSITE FENCING SYSTEM

**BEAUTY AND PRIVACY FROM EVERY ANGLE**  
Make your backyard a true masterpiece. Frame it with Trex Seclusions®. This composite fencing system offers the perfect backdrop to compliment any backyard paradise. With lasting beauty and low maintenance, it's the perfect fencing solution.



Learn more at  
[trexfencing.com/videos](http://trexfencing.com/videos)

**Trex®**  
OUTDOOR LIVING. DEFINED.  
Visit  
**trexfencing.com**

© 2016 Trex Company, Inc. All rights reserved. Trex®, the Trex logo and Trex Seclusions® are either federally registered trademarks, Trade marks or registered of The Trex Company, Inc. Winchester, Virginia 10221016



# Trex® Seclusions® Composite Fencing

ARCHITECTURAL DRAWING:  
TREX SECLUSIONS FENCING  
PROFILE VIEW

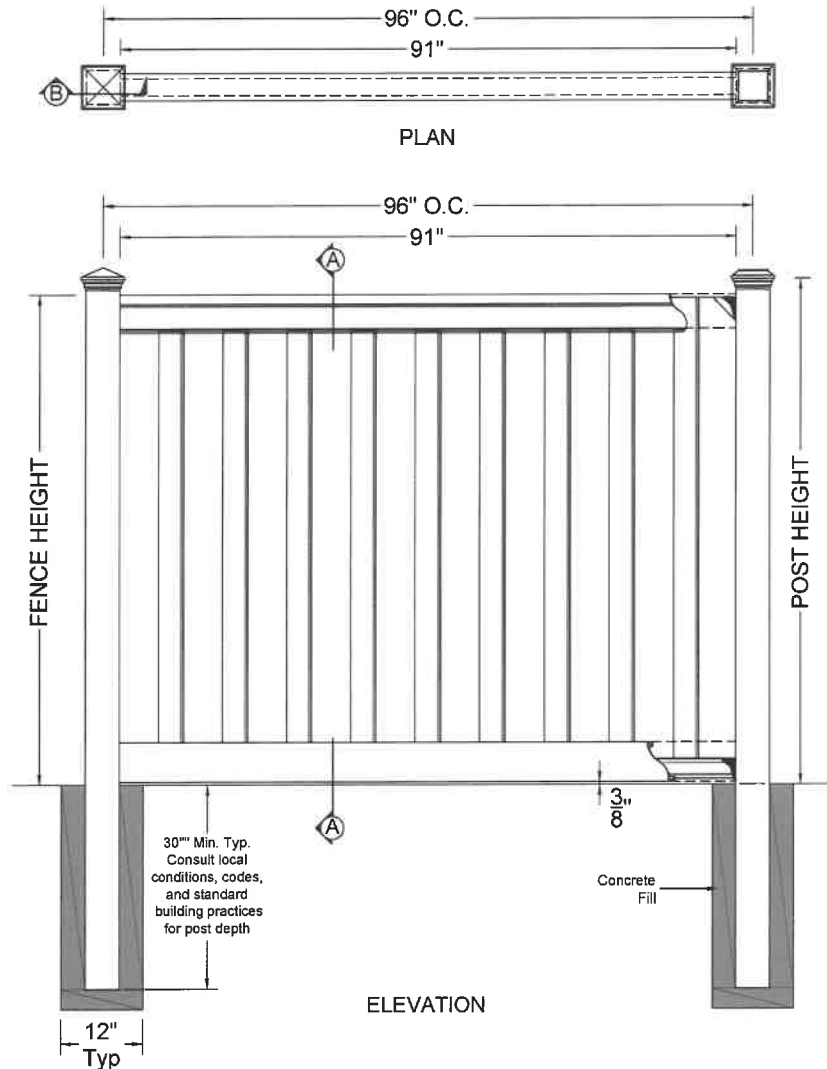

BILL OF MATERIAL FOR A 6'H x 8'W SECTION OF SECLUSIONS FENCINGS		
COMPONENTS	QUANTITY	LENGTH
Post Cap: Pyramid, Flat, or Crown	1	
5" x 5" Post	1	106" *
4" x 4.9" Top Rail	1	91" *
1"x5.75" Interlocking Picket	19	67" *
1" x 5.75" Bottom Rail Cover	2	91" *
Aluminum Bottom Rail	1	90 1/2"
Fence Bracket	4	
1 5/8" (Typ) Exterior Wood Screws	24	

\* Length may vary

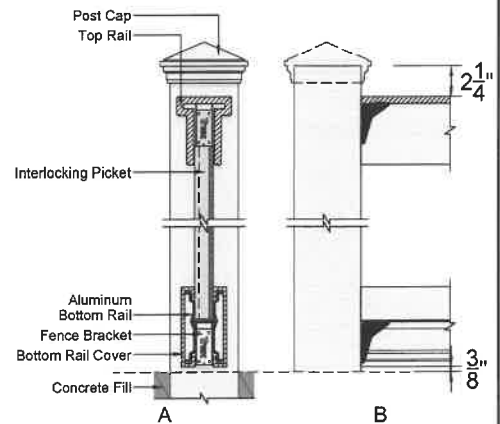

SECTIONS

**NOTES:**

1. INSTALLATION TO BE COMPLETED PER MANUFACTURER'S SPECIFICATION.
2. THIS DRAWING IS PROVIDED FOR PLANNING PURPOSES. REFER TO MANUFACTURER'S INSTALLATIONS FOR CONSTRUCTION DETAILS.
3. REFER TO MANUFACTURER'S WEBSITE FOR PRODUCT INFORMATION.
4. DRAWING NOT TO SCALE.

## TREX SECLUSIONS FENCING PROFILE VIEW

160 EXETER DR, WINCHESTER, VA 22603  
1-800-BUY-TREX / WWW.TREXFENCING.COM

# Trex® Seclusions®

## COMPOSITE FENCING SYSTEM

ARCHITECTURAL DRAWING:  
TREX SECLUSIONS FENCING  
6' TALL x 8' WIDE

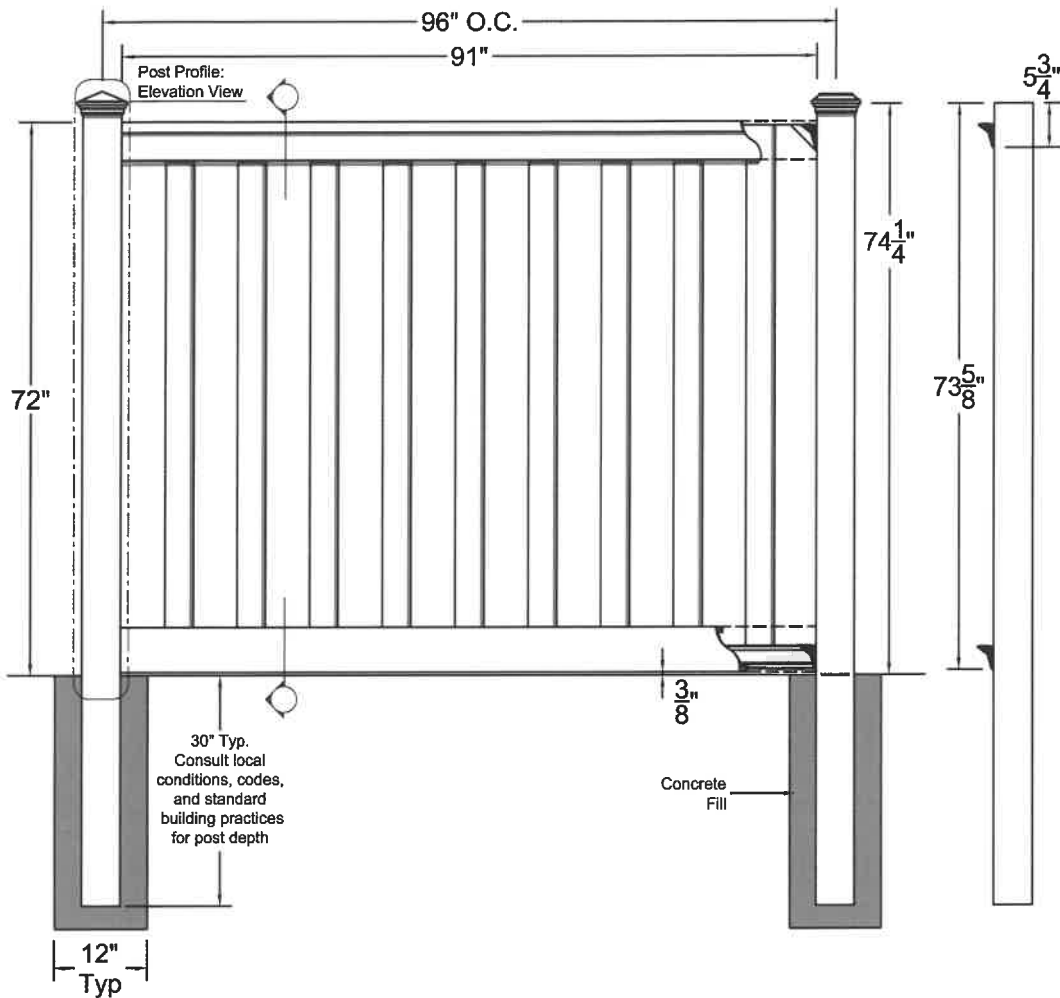

COMPONENTS	QUANTITY	LENGTH
Post Cap: Pyramid, Flat, or Crown	1	
5" x 5" Post	1	108" *
4" x 4.9" Top Rail	1	91" *
1" x 5.75" Interlocking Picket	19	67" *
1" x 5.75" Bottom Rail Cover	2	91" *
Aluminum Bottom Rail	1	90 1/2"
Fence Bracket	4	
1 5/8" (Typ) Exterior Wood Screws	24	

\* Length may vary

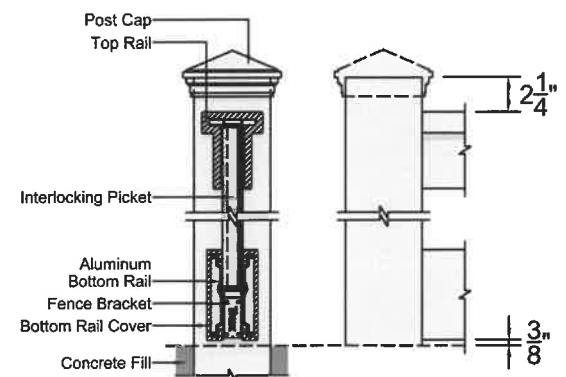

Post Profile: Cut View / Elevation View

### NOTES:

1. INSTALLATION TO BE COMPLETED PER MANUFACTURER'S SPECIFICATION.
2. THIS DRAWING IS PROVIDED FOR PLANNING PURPOSES. REFER TO MANUFACTURER'S INSTALLATIONS FOR CONSTRUCTION DETAILS.
3. REFER TO MANUFACTURER'S WEBSITE FOR PRODUCT INFORMATION.
4. DRAWING NOT TO SCALE.

160 EXETER DR., WINCHESTER VA, 22603

WWW.TREXFENCING.COM

Trex®, the Trex® logo, and Trex Seclusions® are either federally registered trademarks, trademarks or trade dress of Trex Company, Inc., Winchester Virginia or its licensees.  
Copyright © 2019 R1 A Designs. All rights reserved.

# Trex® Seclusions® Composite Fencing

ARCHITECTURAL DRAWING:  
TREX SECLUSIONS FENCING  
PROFILE VIEW

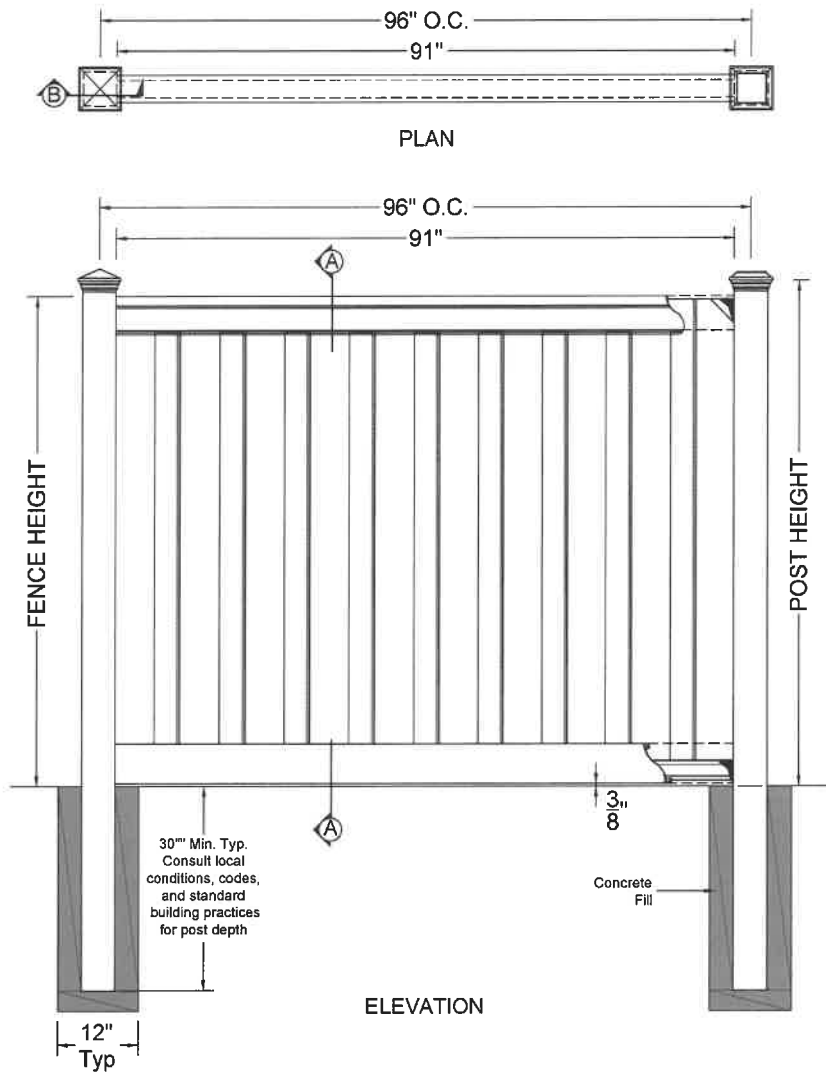

**BILL OF MATERIAL FOR A 6'H x 8'W SECTION OF SECLUSIONS FENCINGS**

COMPONENTS	QUANTITY	LENGTH
Post Cap: Pyramid, Flat, or Crown	1	
5" x 5" Post	1	106" *
4" x 4.9" Top Rail	1	91" *
1"x5.75" Interlocking Picket	19	67" *
1" x 5.75" Bottom Rail Cover	2	91" *
Aluminum Bottom Rail	1	90 1/2"
Fence Bracket	4	
1 5/8" (Typ) Exterior Wood Screws	24	

\* Length may vary

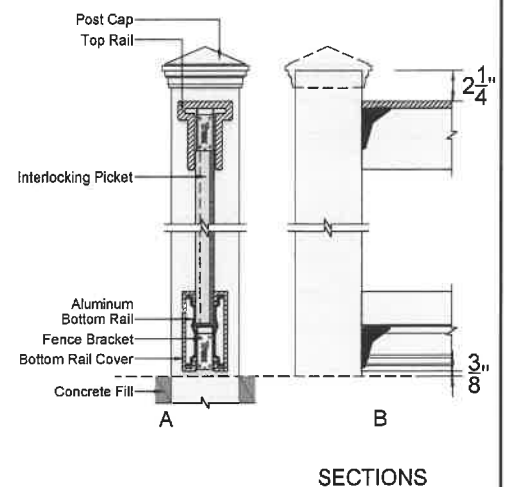

**NOTES:**

1. INSTALLATION TO BE COMPLETED PER MANUFACTURER'S SPECIFICATION.
2. THIS DRAWING IS PROVIDED FOR PLANNING PURPOSES. REFER TO MANUFACTURER'S INSTALLATIONS FOR CONSTRUCTION DETAILS.
3. REFER TO MANUFACTURER'S WEBSITE FOR PRODUCT INFORMATION.
4. DRAWING NOT TO SCALE.

## TREX SECLUSIONS FENCING PROFILE VIEW

160 EXETER DR, WINCHESTER, VA 22603  
1-800-BUY-TREX / WWW.TREXFENCING.COM





March 29, 2023

TO: Tim Wolf  
1670 Avonlea Drive  
Rockwall, TX 75087

FROM: Bethany Ross  
City of Rockwall Planning and Zoning Department  
385 S. Goliad Street  
Rockwall, TX 75087

SUBJECT: MIS2023-004; *Exception to the Fence Material Requirements*

Tim:

This letter serves to notify you that the above referenced case (*i.e. Miscellaneous Case*) that you submitted for consideration by the City of Rockwall was approved by the Planning and Zoning Commission on March 28, 2023. The following is a record of all recommendations, voting records and conditions of approval:

Staff Recommendations

- (1) Any construction resulting from the approval of this Miscellaneous Case shall conform to the requirements set forth by the Unified Development Code (UDC), the International Building Code (IBC), the Rockwall Municipal Code of Ordinances, city adopted engineering and fire codes and with all other applicable regulatory requirements administered and/or enforced by the state and federal government.

Planning and Zoning Commission

On March 28, 2023, the Planning and Zoning Commission approved a motion to approve the *Exception* by a vote of 7-0.

Should you have any questions or concerns regarding your case, please feel free to contact me a (972) 772-6488.

Sincerely,

A handwritten signature in black ink that reads "Bethany Ross".

Bethany Ross, *Planner*  
City of Rockwall Planning and Zoning Department

## Ross, Bethany

---

**From:** Ross, Bethany  
**Sent:** Friday, March 24, 2023 10:17 AM  
**To:** 'T.wolf@rockwallems.com'  
**Subject:** Project Comments for MIS2023-004: Exception to the Fence Material Requirements  
**Attachments:** Project Comments (03.24.2023).pdf

Good Morning Tim,

Attached are the project comments for your case. The meeting schedule for this case is as follows:

Planning and Zoning Commission: March 28, 2023

Please note that all meetings will be held at 6:00 PM at 385 S. Goliad Street in the City Council Chambers. Please also note that a representative is REQUIRED to be at all meetings. Should you have any questions please let me know. Thanks.

Bethany Ross  
Planner  
City of Rockwall  
972.772.6488 Office  
[brross@rockwall.com](mailto:brross@rockwall.com)  
[City of Rockwall - Planning & Zoning](#)