

TABLE OF DIMENSIONS & REINFORCING STEEL
(Wings for One Structure End)

Dimensions	Variable Reinforcing				Estimated Quantities per ft of wing (2-Wings)		Estimated Quantities per ft of Toewall (1-Toewall)					
	W	X	Y	Z	Bars J1	Bars J2	Reinf (Lb/Ft)	Conc (CY/Ft)				
Maximum Wingwall Height Hw					Size	Spa	Size	Spa	Reinf (Lb/Ft)	Conc (CY/Ft)	Reinf (Lb/Ft)	Conc (CY/Ft)
2'-6"	2'-10"	10"	1'-0"	7"	#4	1'-0"	#4	1'-0"	43.13	0.406	6.85	0.071
2'-9"	2'-10"	10"	1'-0"	7"	#4	1'-0"	#4	1'-0"	43.80	0.424	6.85	0.071
3'-0"	2'-10"	10"	1'-0"	7"	#4	1'-0"	#4	1'-0"	44.47	0.444	6.85	0.071
3'-3"	2'-10"	10"	1'-0"	7"	#4	1'-0"	#4	1'-0"	47.81	0.462	6.85	0.071
3'-6"	2'-10"	10"	1'-0"	7"	#4	1'-0"	#4	1'-0"	48.48	0.480	6.85	0.071
4'-0"	3'-2"	1'-2"	1'-0"	7"	#4	1'-0"	#4	1'-0"	50.26	0.532	6.85	0.071
4'-6"	3'-2"	1'-2"	1'-0"	7"	#4	1'-0"	#4	1'-0"	54.27	0.568	6.85	0.071
5'-0"	3'-9"	1'-7"	1'-2"	7"	#4	1'-0"	#4	1'-0"	57.94	0.632	6.96	0.075
5'-6"	3'-9"	1'-7"	1'-2"	7"	#4	1'-0"	#4	1'-0"	61.95	0.668	6.96	0.075
6'-0"	4'-4"	2'-0"	1'-4"	7"	#5	1'-0"	#5	1'-0"	75.16	0.730	7.07	0.078
6'-6"	4'-4"	2'-0"	1'-4"	7"	#5	1'-0"	#5	1'-0"	79.54	0.768	7.07	0.078
7'-0"	5'-0"	2'-3"	1'-9"	8"	#5	1'-0"	#5	1'-0"	86.65	0.864	8.07	0.093
7'-6"	5'-0"	2'-3"	1'-9"	8"	#5	1'-0"	#5	1'-0"	91.03	0.902	8.07	0.093
8'-0"	5'-6"	2'-8"	1'-10"	8"	#5	6"	#5	6"	133.54	0.962	8.13	0.095
8'-6"	5'-6"	2'-8"	1'-10"	8"	#5	6"	#5	6"	138.96	1.000	8.13	0.095
9'-6"	6'-0"	2'-10"	2'-2"	9"	#5	6"	#5	6"	151.43	1.136	8.41	0.110
10'-6"	6'-5"	3'-0"	2'-5"	9"	#6	6"	#5	6"	190.76	1.234	8.57	0.117
11'-6"	7'-2"	3'-6"	2'-8"	11"	#6	6"	#6	6"	224.62	1.438	9.52	0.140
12'-6"	7'-8"	3'-9"	2'-11"	1'-0"	#7	6"	#6	6"	277.90	1.592	9.74	0.157
13'-6"	8'-2"	4'-0"	3'-2"	1'-2"	#8	6"	#6	6"	343.21	1.804	10.02	0.186
14'-6"	8'-10"	4'-5"	3'-5"	1'-4"	#9	6"	#6	6"	427.43	2.046	10.30	0.218
15'-6"	9'-6"	4'-10"	3'-8"	1'-6"	#9	6"	#7	6"	484.01	2.302	11.24	0.253
16'-0"	9'-11"	5'-0"	3'-11"	1'-7"	#9	6"	#7	6"	500.21	2.448	11.47	0.279

TABLE OF WINGWALL REINFORCING (2-Wings)

Bar	Size	No.	Spa
D1	#6	~	1'-0"
D2	#6	~	1'-0"
E1	#4	~	1'-0"
F	#4	~	1'-0"
G	#6	~	1'-0"
M1	#4	4	~
P	#4	~	1'-0"
V	#4	~	1'-0"

TABLE OF TOEWALL REINFORCING

Bar	Size	No.	Spa
J3	#4	~	1'-0"
M2	#4	2	~
E2	#4	~	1'-0"

WING DIMENSION CALCULATIONS:

Formulas: (All values are in Feet)
 $Hw = H + T + C$
 $Lw = (Hw) (SL) \div \text{Cosine } (V)$
 For Cast-in-place culverts:
 $Ltw = [(N) (S) + (N + 1) (U)] \div \text{Cosine } (V)$
 For Precast culverts:
 $Ltw = [(N) (2U + S) + (N - 1) (0.5')] \div \text{Cosine } (V)$
 Total Wingwall Area (Two Wings ~ S.F.)
 $= (2) (Hw) (Lw)$

Hw = Height of Wingwall
 Lw = Length of Wingwall
 Ltw = Culvert Toewall Length
 N = Number of Culvert Spans
 SL:1 = Channel Slope ratio. (Horizontal: 1 Vertical, Usual value is 2:1)
 V = Culvert Skew

See applicable box culvert standard for S, H, T and U values.

- Skew Angle = 0°
- At discharge end, chamfer may be 3/4".
- For 15° Skew ~ 1"
For 30° Skew ~ 2"
For 45° Skew ~ 3"
- Quantities shown are for two wings. To determine total quantities for two wings, multiply the tabulated values by Lw.
- Provide weepholes for Hw = 5'-0" and greater. Fill around weepholes with coarse gravel.
- Extend Bars E1 1'-6" minimum into the bottom slab of the culvert.
- Lap Bars M1 1'-6" minimum with Bars M2.
- Bars G shall be equally spaced at 8" maximum, placed as shown. There shall be at least 4 Bars G per wing.
- 0" min to 5'-0" max. For T6 or C6 Rail, see T6-CM standard for additional details. For all other rail types, refer to the RAC standard. For curbs without rail and greater than 1'-0" high, see ECD standard for additional details. Estimated curb heights are shown elsewhere in the plans.
- For vehicle safety, the following requirements must be met:
 - For structures without bridge rail, curbs shall project no more than 3" above finished grade.
 - For structures with bridge rail, curbs shall be flush with finished grade.
 Curb heights shall be reduced, if necessary, to meet the above requirements. No changes will be made in quantities and no additional compensation will be allowed for this work.
- 1'-0" typical. 2'-0" typical when RAC standard is referenced elsewhere in the plans.

GENERAL NOTES:

Designed according to current AASHTO Standard and Interim Specifications.
 All reinforcing steel shall be Grade 60.
 All concrete shall be Class "C" and shall have a minimum compressive strength of 3600 psi.
 All reinforcing bars shall be adjusted to provide a minimum of 1 1/4" clear cover.
 When structure is founded on solid rock, depth of toewalls for culverts and wingwalls may be reduced or eliminated as directed by the Engineer.
 See BCS sheet for additional dimensions and information.
 The quantities for concrete and reinforcing steel resulting from the formulas given on this sheet are for Contractor's information only.

DISCLAIMER: The use of this standard is governed by the "Texas Engineering Practice Act". No warranty of any kind is made by TxDOT for any purpose whatsoever. TxDOT assumes no responsibility for the conversion of this standard to other formats or for incorrect results or damages resulting from its use.

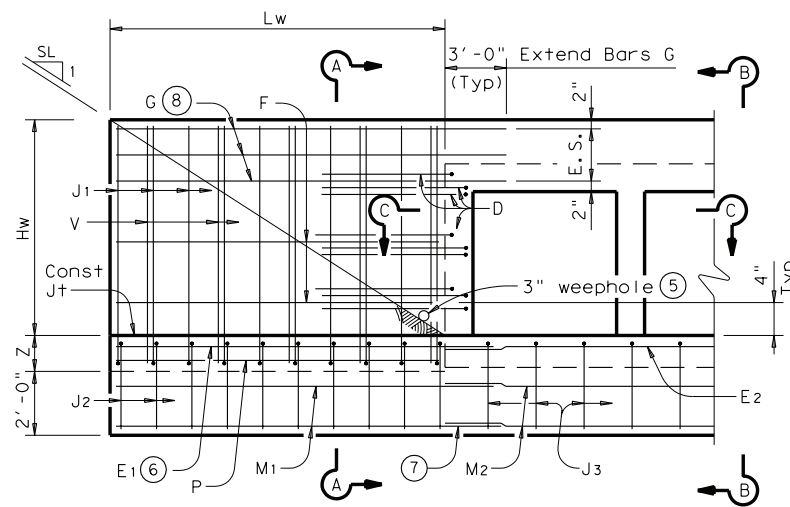

PARTIAL ELEVATION

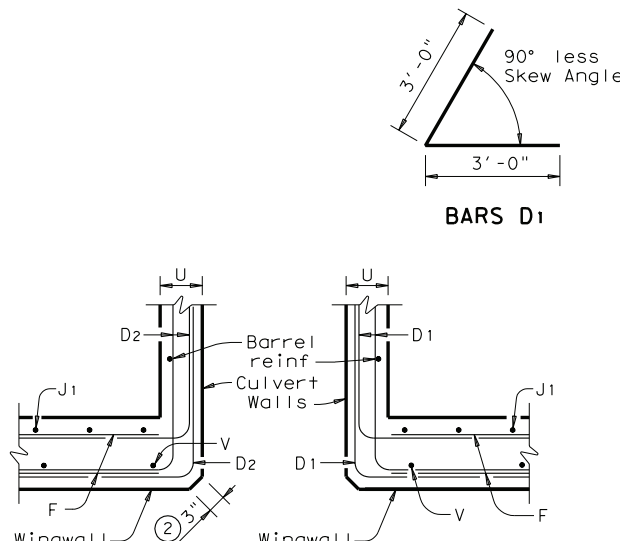

SECTION C-C

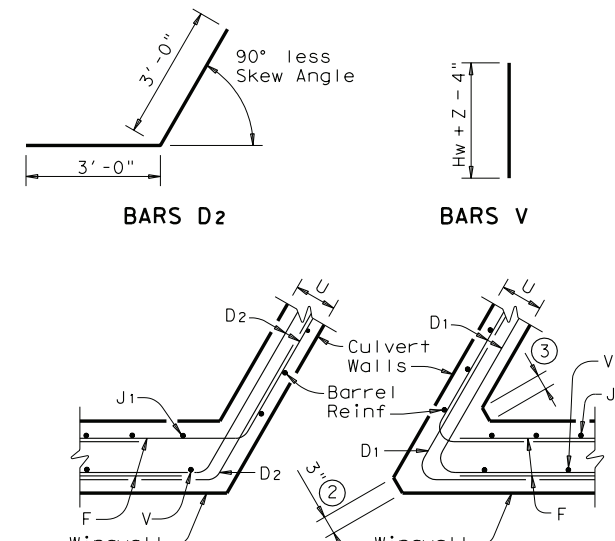

SECTION C-C

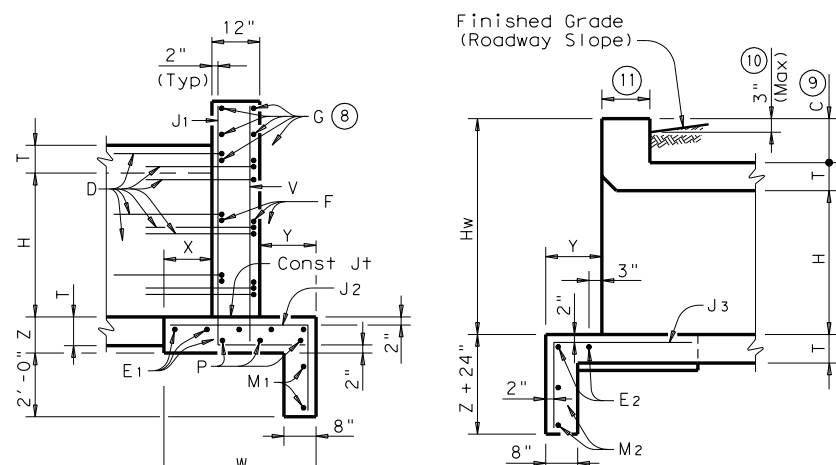

SECTION A-A

(Showing Wing Reinf)

SECTION B-B

(Showing Toewall Reinf)

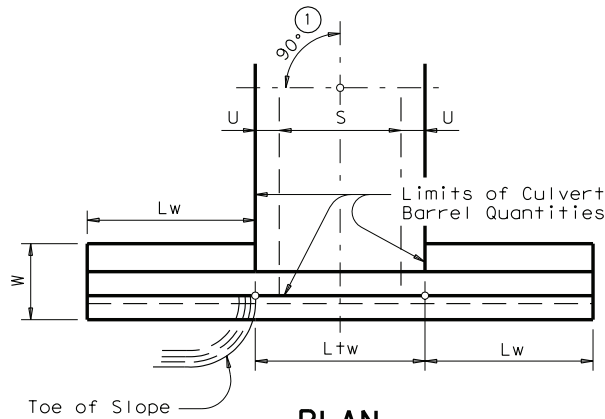

PLAN

DETAILS FOR NON-SKEWED BOX CULVERTS

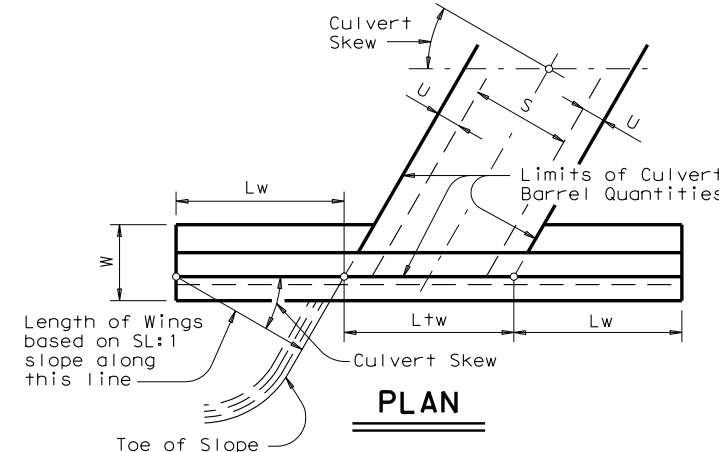

PLAN

DETAILS FOR SKEWED BOX CULVERTS

(Showing 30° Skew)

LEVELS DISPLAYED	ACC:
1	

CONCRETE WINGWALLS WITH PARALLEL WINGS FOR SKEWED AND NON-SKEWED BOX CULVERTS

PW

FILE: pwstde01.dgn	DN: GAF	CK: CAT	DW: TxDOT	CK: GAF
© TxDOT May 2005	DISTRICT	FEDERAL AID PROJECT	SHEET	
REVISIONS				
08-07: Size & No. of Bars D, Size & Lgth of Bars G.	COUNTY	CONTROL	SECT	JOB HIGHWAY