

CONCRETE COLLAR FOR PIPE CONNECTION

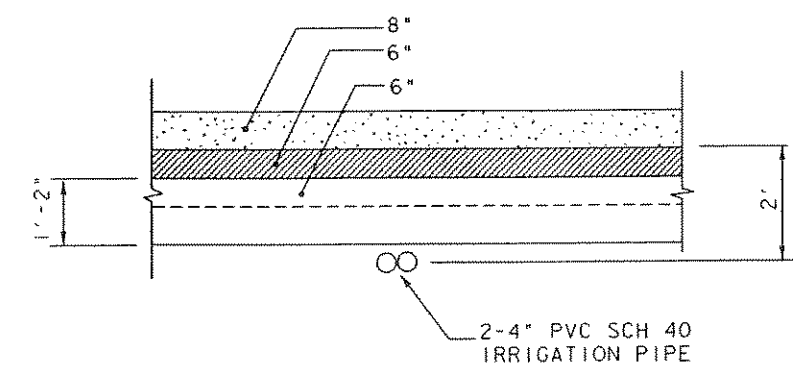

- NOTES:
1. DRIVEWAY LOCATIONS MAY BE SHIFTED AT THE TIME OF CONSTRUCTION AS DIRECTED BY THE ENGINEER TO MATCH EXISTING CONDITIONS.
 2. OMIT PAYMENT FOR CURB WITHIN LIMITS OF DRIVEWAY. CURBS ON DRIVEWAYS SHALL BE CONSIDERED SUBSIDIARY TO THE PRICE BID PER SQUARE YARD FOR DRIVEWAY AND WILL NOT BE PAID FOR DIRECTLY.

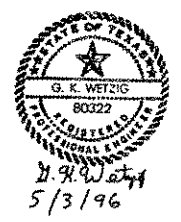

MISCELLANEOUS SHEET
SHEET 2 OF 2

FED. RD. DIV. NO.	FEDERAL AID PROJECT NO.	SHEET NO.
6	STP 96 (830)MM	27
STATE	STATE DIST. NO.	COUNTY
TEXAS	DALLAS	ROCKWALL
CONF.	SECT.	JOB
1014	03	041
		HIGHWAY NO.
		FM 740

REFERENCE	FILES	HORIZONTAL & VERTICAL	ALIGNMENT
FM740MISC.DGN	FM740MISC.DGN	FM740MISC.DGN	FM740MISC.DGN
FL	9	9	9
DESIGN FILES	DESIGN FILES	DESIGN FILES	DESIGN FILES
FM740MISC.DGN	FM740MISC.DGN	FM740MISC.DGN	FM740MISC.DGN