

**SPRINGER ELEMENTARY SCHOOL
 ROCKWALL INDEPENDENT SCHOOL DISTRICT
 ROCKWALL, TEXAS**

FINAL PLANS FOR BIDDING AND CONSTRUCTION

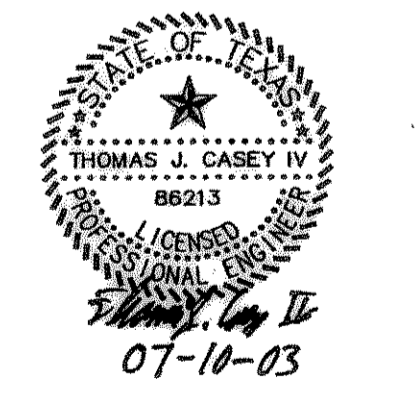

SHW Group Inc.
 Architects + Engineers

SHEET NUMBER: **C**
2.25
 OF

SET NUMBER
 © 2003 SHW Group, Inc.

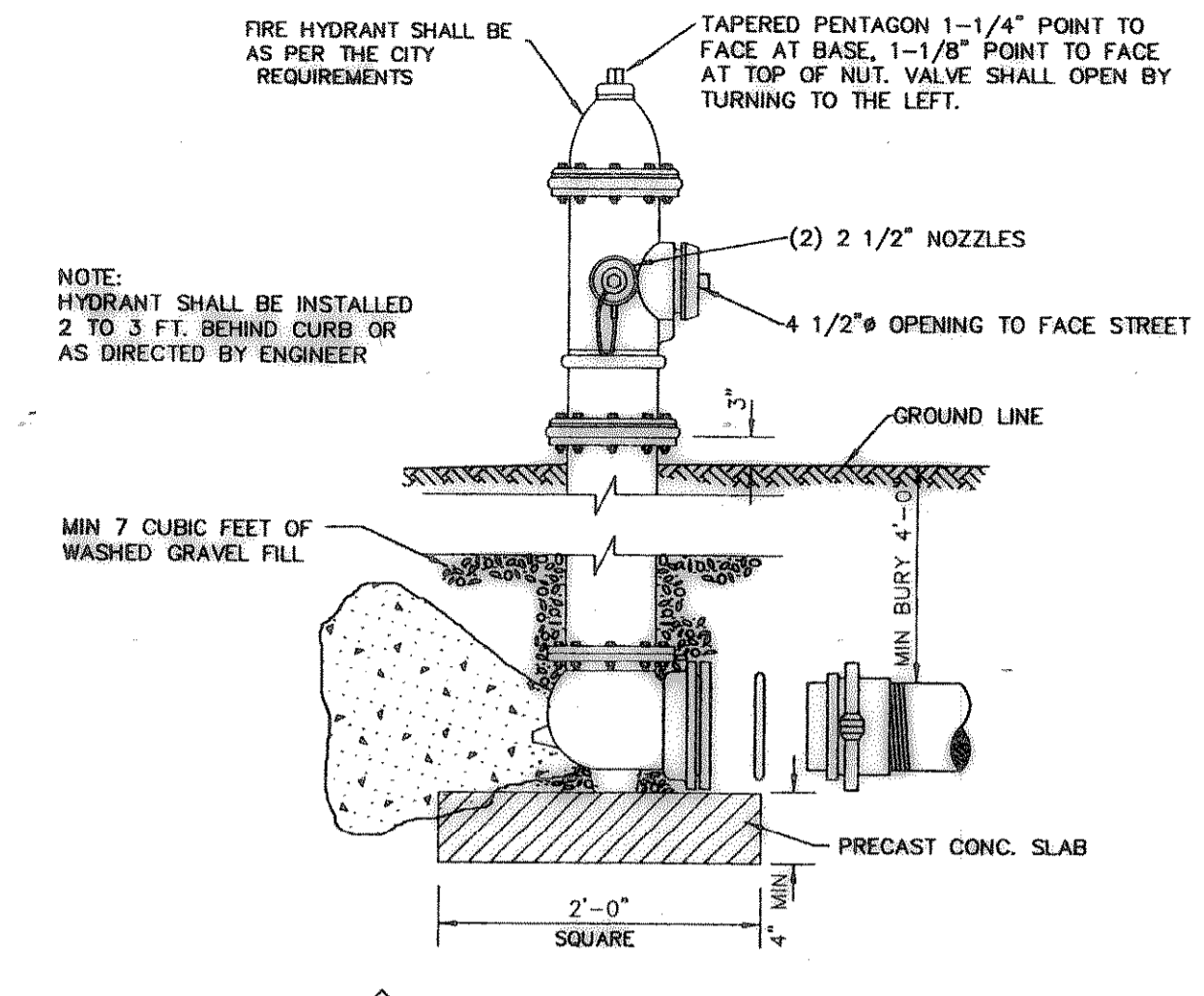

**FIRE HYDRANT ASSEMBLY DETAIL
 RESTRAINED JOINT INSTALLATION**

NOTE: USE WHERE THERE IS INSUFFICIENT UNDISTURBED TRENCH TO BLOCK HYDRANT.

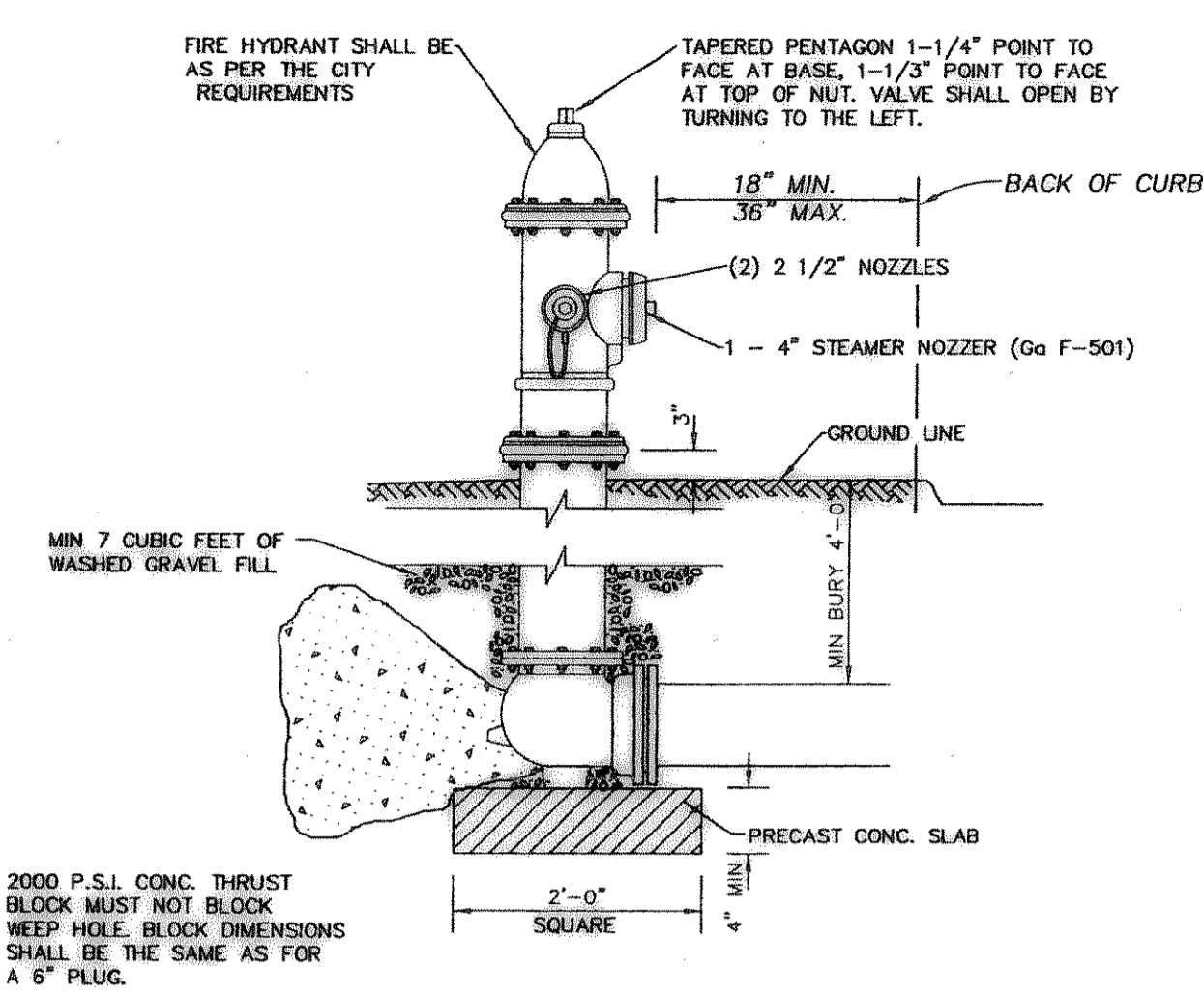

**FIRE HYDRANT ASSEMBLY DETAIL
 BLOCKED INSTALLATION**

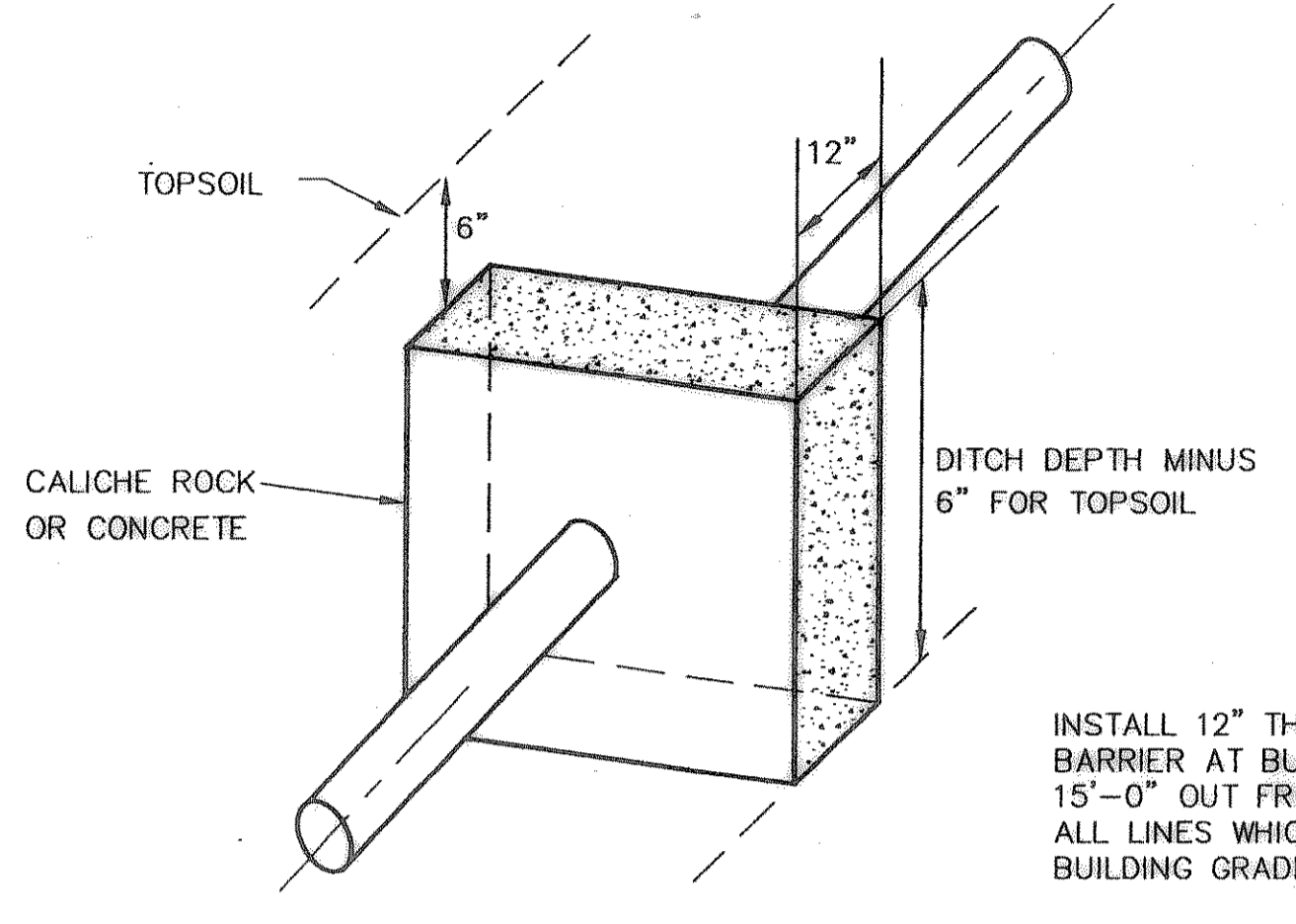
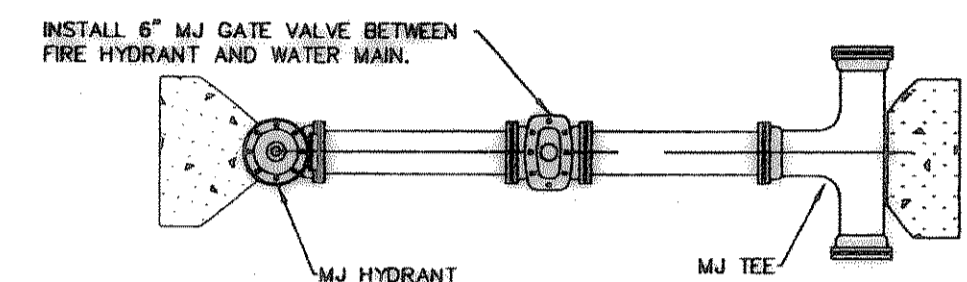

IMPERVIOUS BARRIER

INSTALL 12" THICK IMPERVIOUS BARRIER AT BUILDING LINE AND 15'-0" OUT FROM BUILDING ON ALL LINES WHICH TRAVEL UNDER BUILDING GRADE BEAM

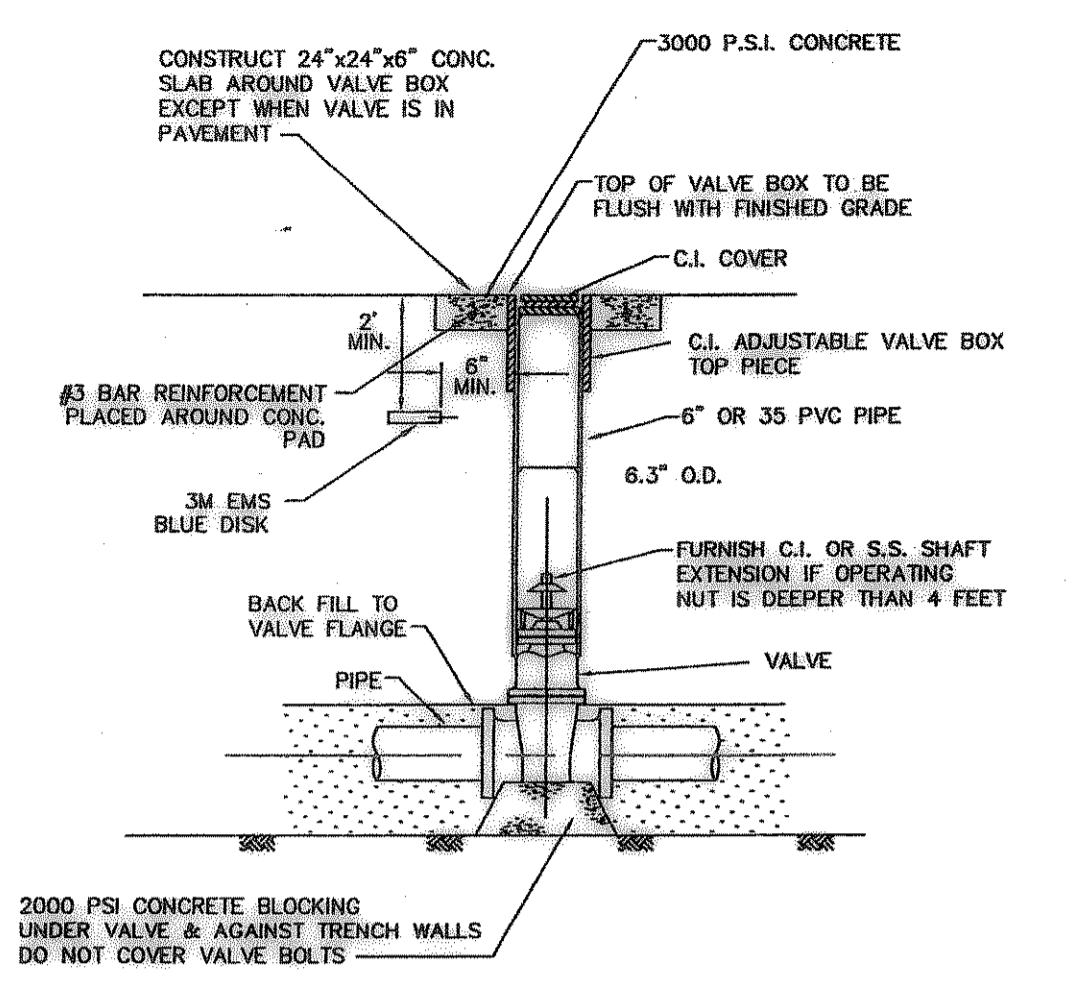

TYPICAL VALVE INSTALLATION DETAIL

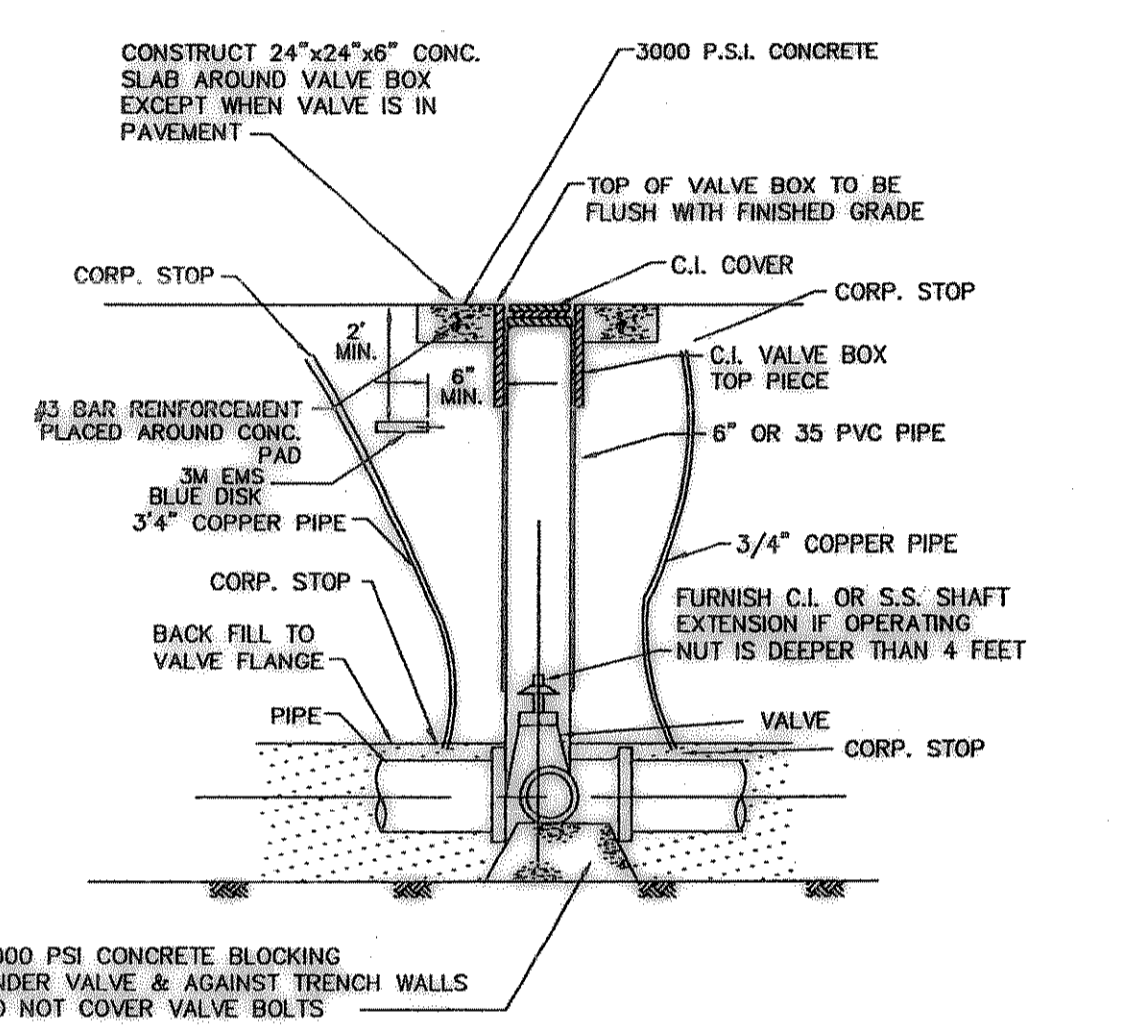

BUTTERFLY VALVE INSTALLATION DETAIL

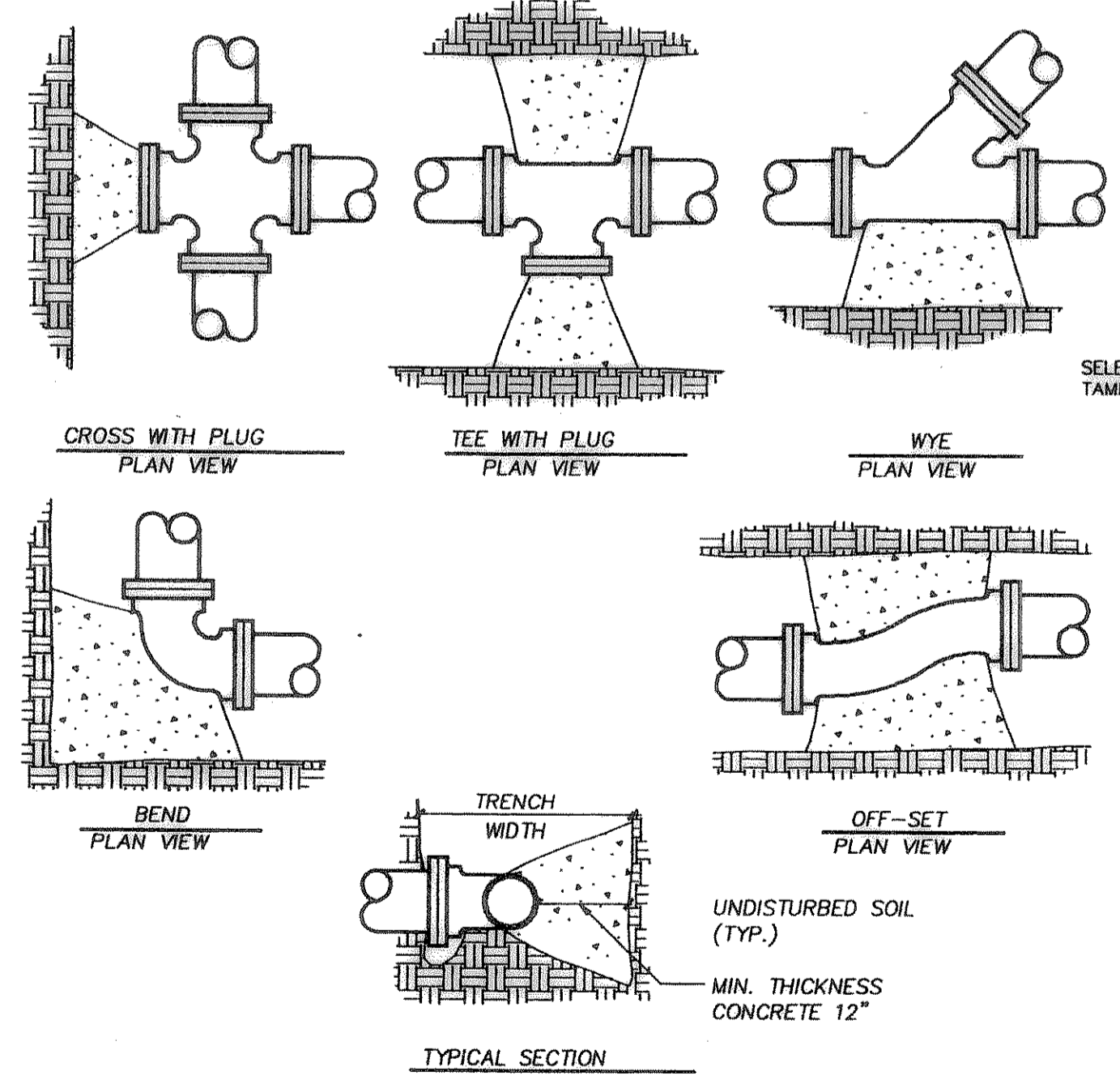

TYPICAL THRUST BLOCKS
 NOT TO SCALE

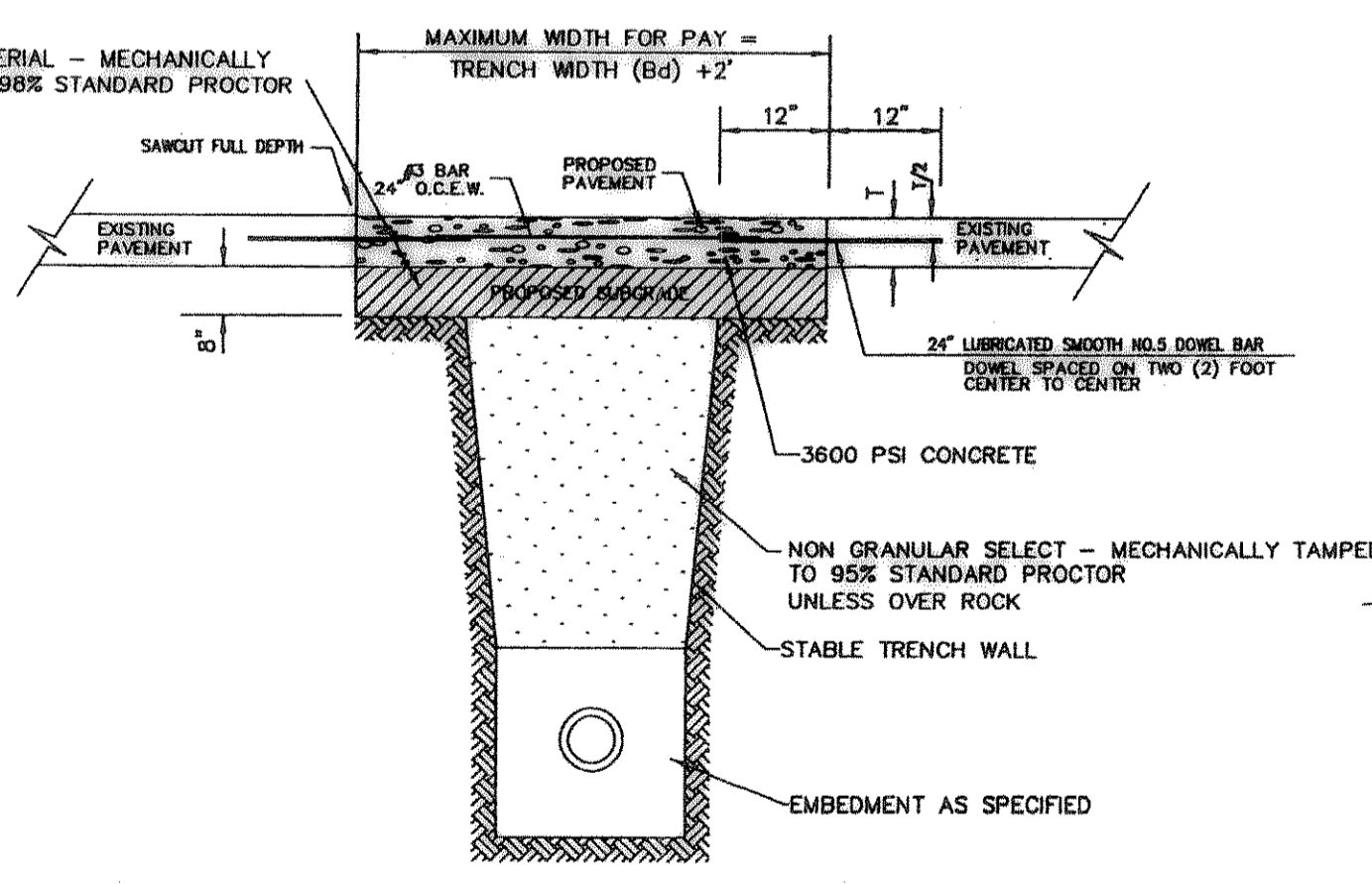

**EMBEDMENT UNDER CONCRETE STREETS
 & PAVEMENT REPAIR DETAIL**

NOTES:
 1. NO. 5 SMOOTH DOWEL BAR MAY BE USED IN 5", 6" AND 7" PAVEMENT THICKNESS.
 2. LONGITUDINAL BUTT CONSTRUCTION MAY BE UTILIZED IN PLACE OF LONGITUDINAL HINGED (KEYWAY) JOINT AT CONTRACTOR'S OPTION.
 3. DOWEL BARS SHALL BE DRILLED INTO PAVEMENT HORIZONTALLY BY USE OF A MECHANICAL RIG. DRILLING BY HAND IS NOT APPLICABLE. PUSHING DOWEL BARS INTO GREEN CONCRETE IS NOT ACCEPTABLE.

N.T.S.

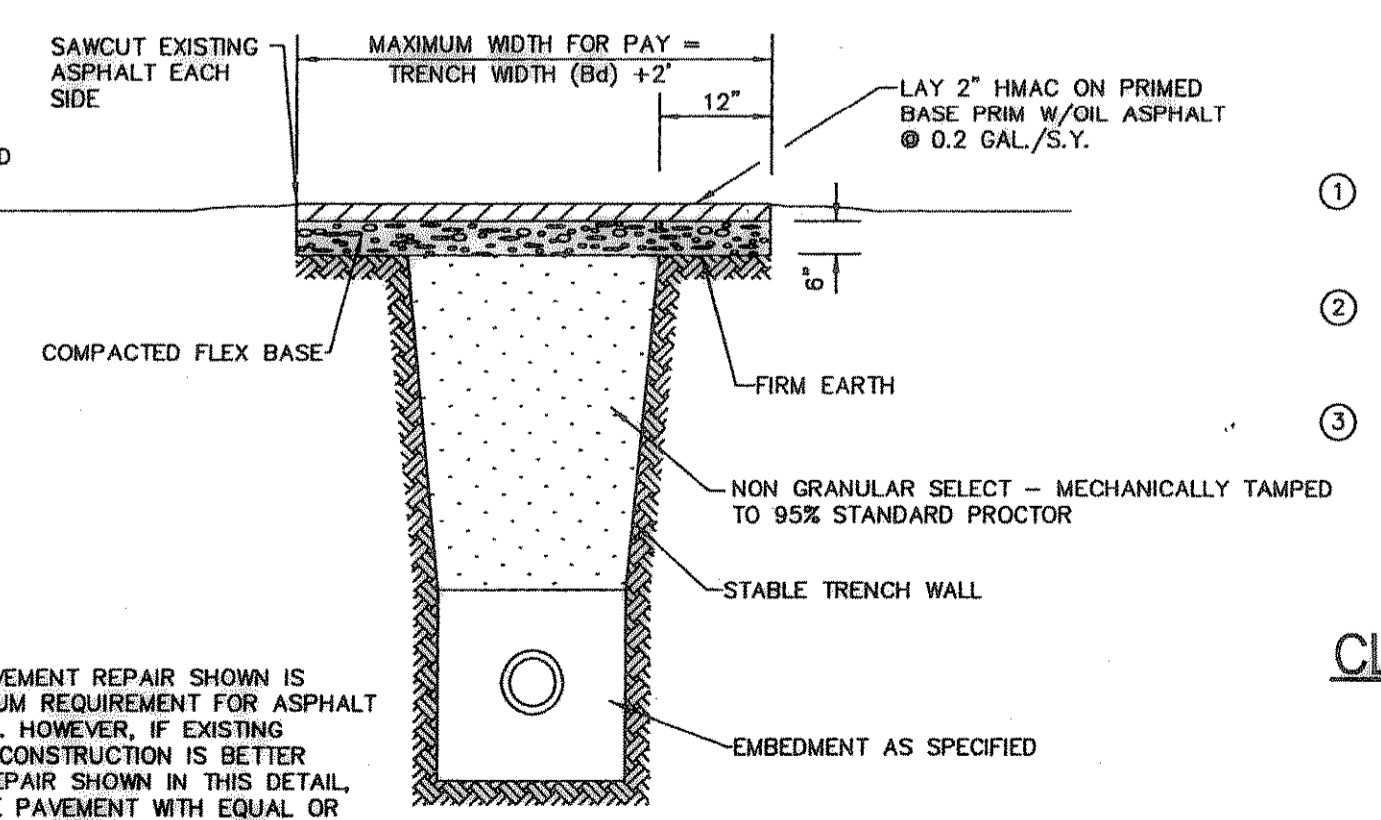

**EMBEDMENT UNDER ASPHALT STREETS
 & PAVEMENT REPAIR DETAIL**

NOTE:
 THE PAVEMENT REPAIR SHOWN IS A MINIMUM REQUIREMENT FOR ASPHALT STREETS. HOWEVER, IF EXISTING STREET CONSTRUCTION IS BETTER THAN REPAIR SHOWN IN THIS DETAIL, REPLACE PAVEMENT WITH EQUAL OR BETTER CONSTRUCTION, MATERIAL, THICKNESSES & QUALITY.

N.T.S.

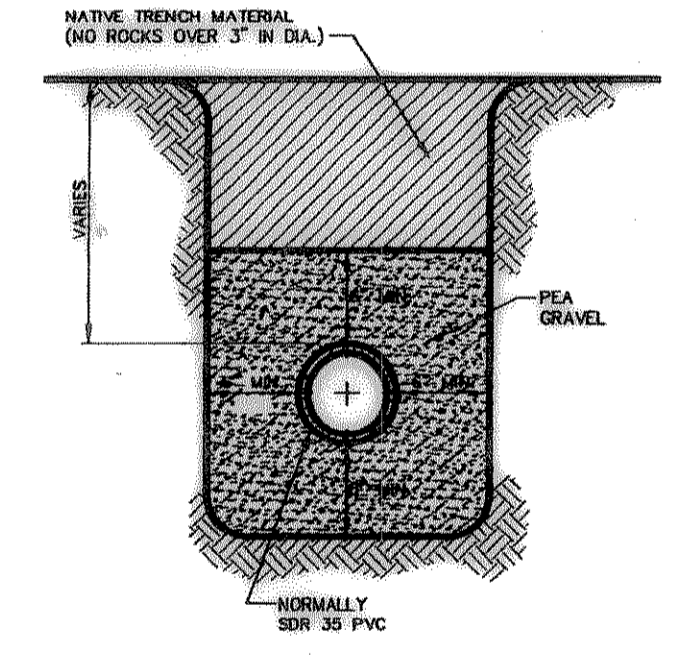

SANITARY SEWER

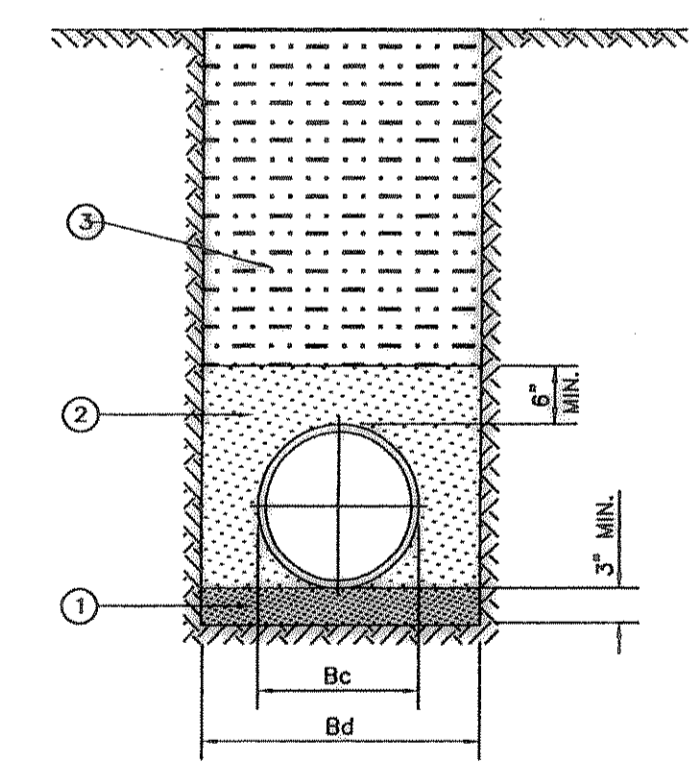

CLASS "C-2" EMBEDMENT

WATER

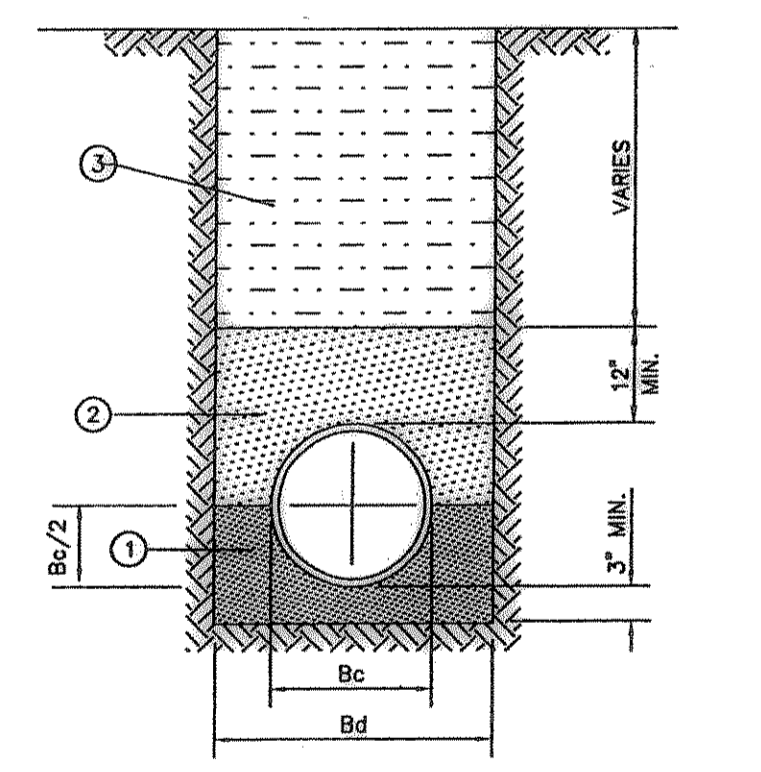

CLASS "B+" EMBEDMENT

ROOF DRAIN LINES, AND STORM SEWER LINES

UTILITY DETAILS

AS SHOWN

These Drawings have been modified to conform to the Construction Records.
 Glenn Engineering Corporation
 By: [Signature] Date: 10-15-04

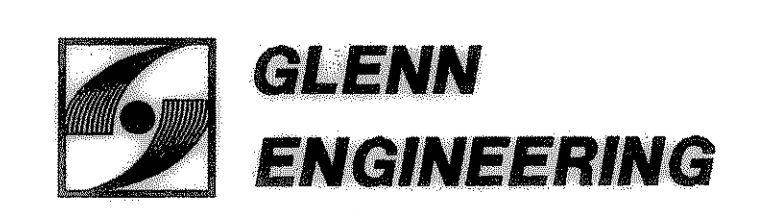

PHONE 972-770-9361 FAX 972-770-2076
 105 DECKER COURT - SUITE 610 IRVING, TEXAS 75038