

C:\PROJECTS\UTLEY\Plans.dwg Wed Jun 17 11:08:19 1998

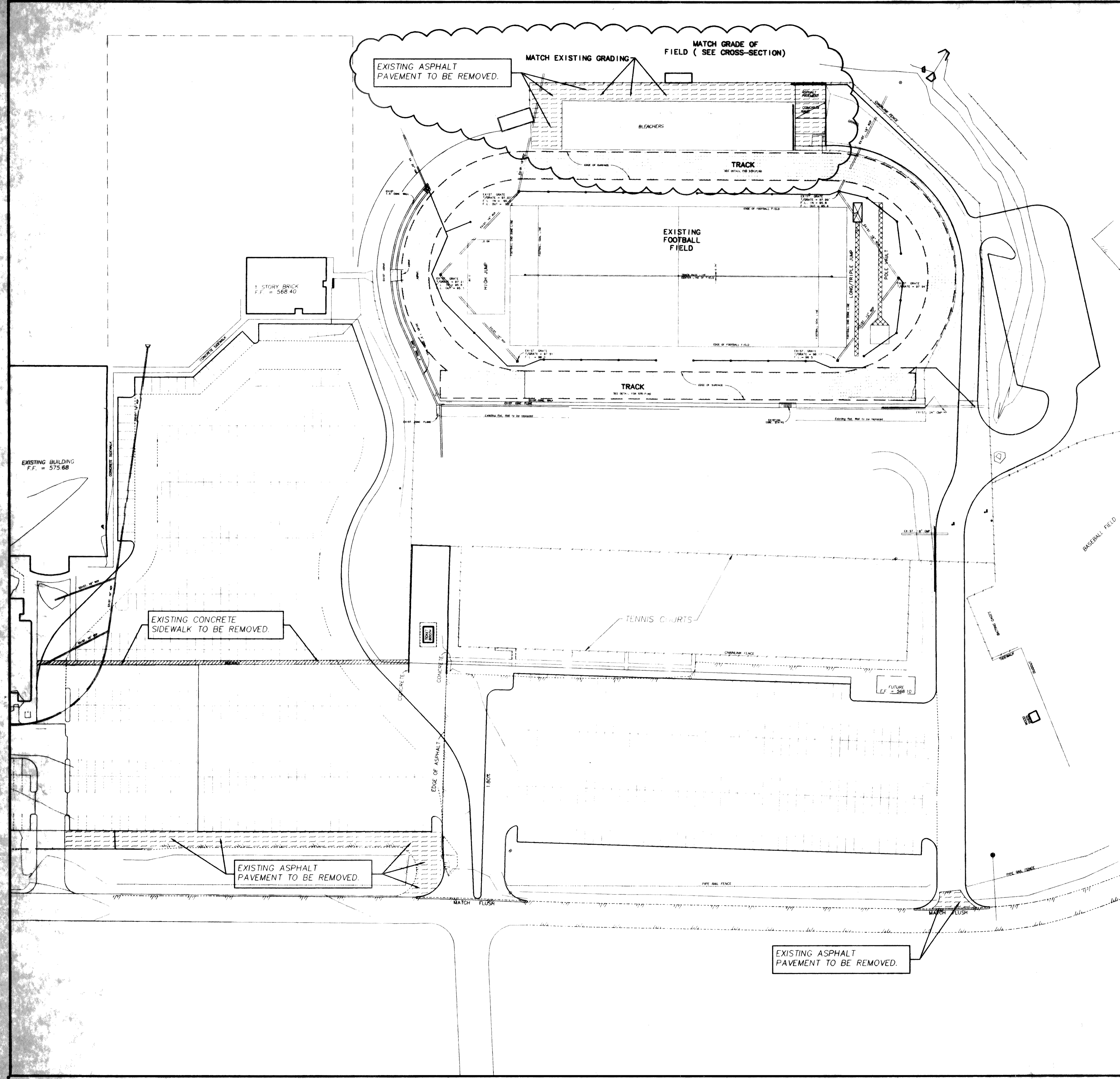

LEGEND
 EXISTING ASPHALT PAVEMENT TO BE REMOVED
 EXISTING CONCRETE SIDEWALK TO BE REMOVED

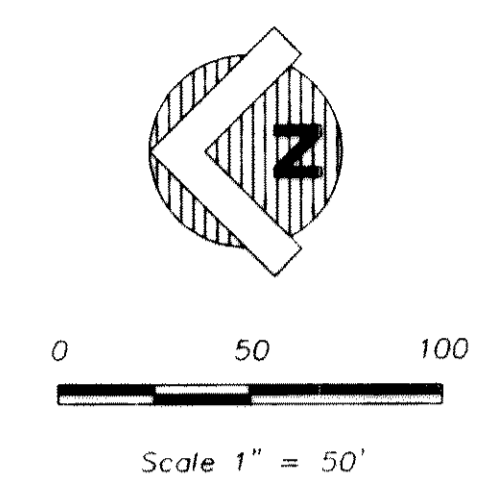

GENERAL SITE DEMOLITION NOTES

1. THE GENERAL CONTRACTOR SHALL VERIFY THE PRECISE HORIZONTAL AND VERTICAL LOCATION OF ALL EXISTING FACILITIES, AND PROPERTY LINES PRIOR TO START OF CONSTRUCTION. THE CONTRACTOR SHALL NOTIFY THE ARCHITECT AND ENGINEER IMMEDIATELY OF ANY CONFLICTS OR DISCREPANCIES WITH EXISTING FACILITIES, PROPERTY LINES, OR GRADES SO THAT REQUIRED DESIGN CHANGES CAN BE MADE PRIOR TO CONSTRUCTION.
2. IF EXISTING FACILITIES INDICATED TO REMAIN ARE DAMAGED DUE TO CONSTRUCTION (INCLUDING SIDEWALKS, PAVING, ETC.) THE CONTRACTOR SHALL REPAIR/REPLACE THEM AT HIS OWN EXPENSE.
3. ALL DIMENSIONS AND RADIUS LENGTHS AS SHOWN ON THESE PLANS ARE TO BACK OF CURB, EDGE OF PAVEMENT, OR OUTSIDE FACE OF BUILDING (U.O.N.).
4. EXCAVATED MATERIAL AND ALL ITEMS TO BE DEMOLISHED, REMOVED, AND DISPOSED OF INCLUDING EXISTING ASPHALT PAVEMENT, CONCRETE PAVEMENT, CONCRETE CURB AND GUTTER, CONCRETE SIDEWALK, INLETS, TREES, ETC. SHALL BECOME THE PROPERTY OF THE CONTRACTOR AND SHALL BE DISPOSED OF OFF SITE BY THE CONTRACTOR AT HIS OWN EXPENSE.
5. WHERE AREAS OF EXISTING PAVING ARE TO BE REMOVED, ALL SAWCUTS SHALL BE CLEAN, SHARP, VERTICAL AND FOR FULL DEPTH OF THE OF THE PAVEMENT OR CURB. ALL DEBRIS SHALL BE REMOVED FROM THE AREA OF CONSIDERATION.
6. THE CONTRACTOR SHALL SAVE AND PROTECT ALL EXISTING SIGNS, POWER POLES, LIGHT POLES, MANHOLES, INLETS, TELEPHONE RISERS, WATER VALVES, WATER METERS, IRRIGATION BOXES, ETC. DURING ALL PHASES OF CONSTRUCTION (U.O.N.).
7. THE CONTRACTOR SHALL CONTACT THE APPROPRIATE UTILITY COMPANY PRIOR TO REMOVAL OF ANY SERVICES.
8. THE CONTRACTOR SHALL BEAR ALL RESPONSIBILITY FOR OBTAINING PERMITS, AND THE BID AMOUNT SHALL INCLUDE ALL PERMITS, FEES, BONDS, INSPECTION AND CONSTRUCTION LAYOUT.
9. PROTECT ALL PLANTS FROM DAMAGE DUE TO CONSTRUCTION. EXISTING TREES AND SHRUBS WILL BE RELOCATED BY THE OWNER.
10. EXISTING LIGHT POLES WILL BE REMOVED AND STORED BY THE OWNER.

NOTE:
 Contractor shall remove all sprinkler heads and equipment in the areas occupied by the construction and staging areas. Terminate/cap off all lines as required. All sprinkler heads and equipment shall be given to the owner. The contractor is responsible for making all necessary changes to the irrigation system that are required to keep the remaining areas outside the construction areas in working order. This includes relocation of any valves, piping, controls, etc., to operate the system.
 At the completion of the construction project, this contractor is responsible for installation of an irrigation system throughout the areas that were involved in the construction. Equipment installed shall be the same as that which was removed. Owner will provide the equipment that was removed back to the contractor. Any additional equipment required will be by the contractor.

SITE DEMOLITION PLAN
 SCALE: 1"=50'

GLENN ENGINEERING
 PHONE 214-778-2211 FAX 214-778-2229
 100 DECKER COURT - SUITE 220 FORT WORTH, TEXAS 76102

DATE MAY 15, 1998
 DRAWN BY R. HOWMAN
 CHECKED R.A.H.
 COORD. NO. 0494453
 REVISIONS JUN 15, 1998

ROCKWALL I.S.D. 1998 PAVING IMPROVEMENTS
WILKERSON SANDERS STADIUM PAVING IMPROVEMENTS
ROCKWALL, TEXAS

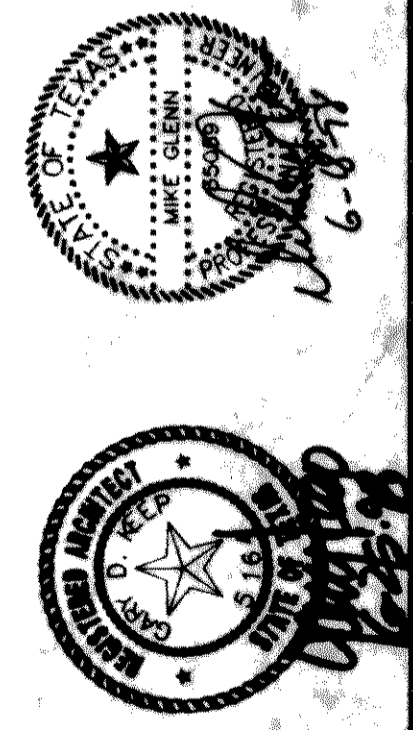

SHW Group Inc.
 Architects + Engineers

SHEET NUMBER	C
OF	4
SET NUMBER	2.1R