

01 LANDSCAPE PLAN
SCALE: 1"=30'-0"
GRAPHIC SCALE

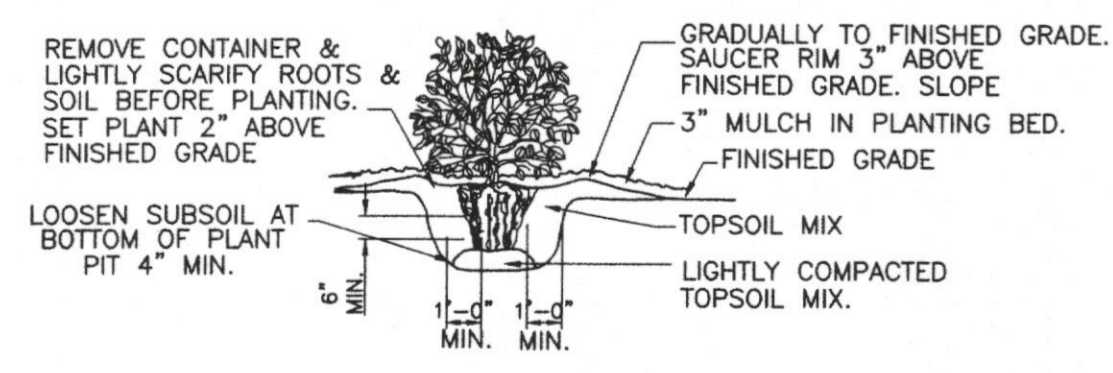

02 SHRUB PLANTING DETAIL
SCALE: NONE

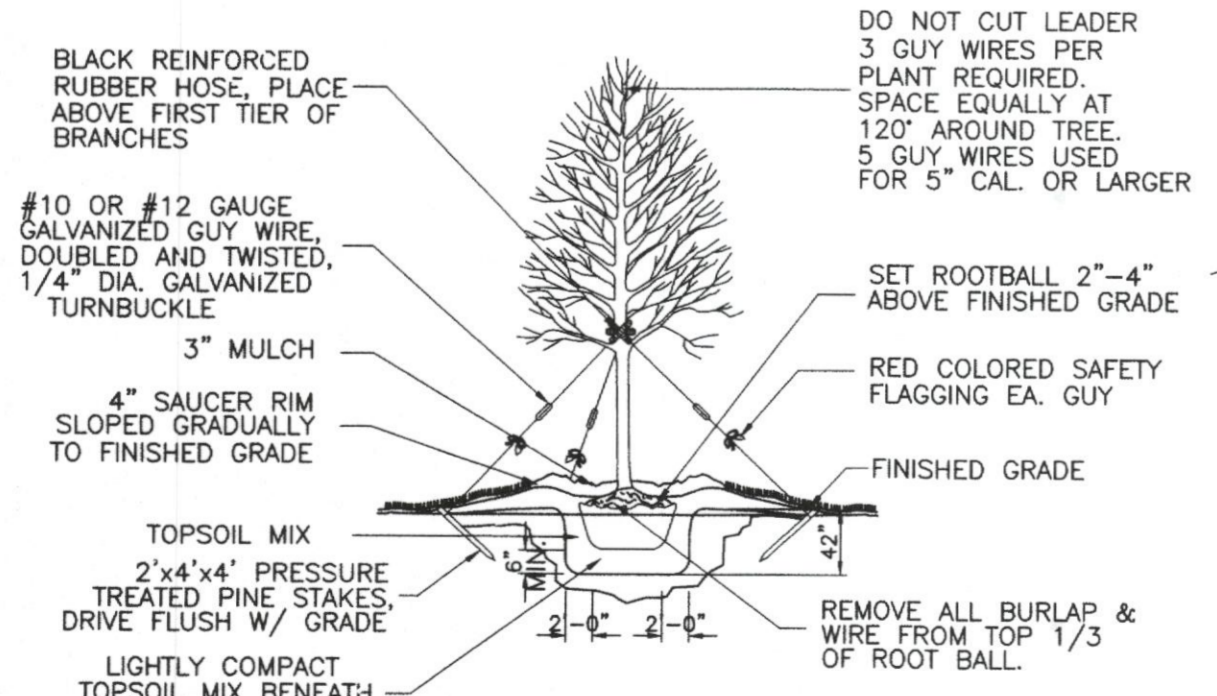

03 TREE PLANTING DETAIL
SCALE: NONE

- GENERAL LANDSCAPE NOTES**
- ALL PLANT MATERIALS SHALL CONFORM TO THE STANDARDS OF THE APPROVED PLANT LIST FOR THE CITY OF ROCKWALL.
 - AN AUTOMATIC LANDSCAPE IRRIGATION SYSTEM SHALL BE INSTALLED TO WATER ALL LANDSCAPED AREAS, INCLUDING RIGHT-OF-WAY AREAS, UNLESS NOTED OTHERWISE ACCORDING TO CITY REQUIREMENTS.
 - ADDITIONAL PLANT MATERIAL MAY BE INSTALLED ON SITE AT OWNER'S DIRECTION AND ACCORDING TO CITY REQUIREMENTS.
 - THE OWNER, TENANT AND/OR THEIR AGENT IF ANY, SHALL BE JOINTLY AND SEVERALLY RESPONSIBLE FOR THE MAINTENANCE OF ALL LANDSCAPING. ALL LANDSCAPING SHALL BE ORDERLY MAINTAINED AT ALL TIMES. MAINTENANCE SHALL INCLUDE, BUT IS NOT LIMITED TO MOWING, EDGING, WEEDING, PRUNING, GRADING, ADDING FERTILIZER, INSTALLING WATER LINES AND SUCH OTHER ACTIVITIES COMMON TO THE MAINTENANCE OF LANDSCAPING. ALL PLANT MATERIALS SHALL BE MAINTAINED IN A HEALTHY AND GROWING CONDITION AS APPROPRIATE FOR THE SEASON OF THE YEAR. PLANT MATERIALS WHICH DIE SHALL BE REPLACED WITH SAME MATERIAL OR THAT WHICH IS SIMILAR IN VARIETY AND SIZE.
 - LANDSCAPED AREAS SHALL BE KEPT FREE OF TRASH, LITTER, AND WEEDS.
 - ALL LANDSCAPED AREAS SHALL BE CONSTRUCTED, INSTALLED AND MAINTAINED SO AS NOT TO OBSTRUCT VIEW OF MOTORIST BETWEEN THE STREET AND ACCESS DRIVE. VISIBILITY EASEMENTS/TRIANGLES SHALL REMAIN UNOBSTRUCTED AT ALL TIMES.
 - ALL PERMEABLE SURFACES NOT OCCUPIED BY TREES, SHRUBS, PLANTING BEDS OR OTHER PERMITTED ITEMS OR FIXTURES SHALL BE GRADED TO ENSURE POSITIVE DRAINAGE.
 - ALL TREES SHALL BE INSTALLED AT LEAST 5' CLEAR OFF FIRE HYDRANTS, WATER LINES, SEWER LINES AND OTHER UTILITIES.
 - REFER TO ENGINEERING PLANS FOR PROPOSED GRADES AND EASEMENTS.

- IRRIGATION NOTES**
- ALL LANDSCAPED AREAS SHALL BE IRRIGATED WITH AN AUTOMATIC IRRIGATION SYSTEM.
 - THE IRRIGATION SYSTEM SHALL BE EQUIPPED WITH A RAIN SENSOR AND FREEZE GUARD.
- TREE NOTES**
- AT THE TIME OF PLANTING, ALL TREES SHALL BE A MINIMUM OF 3" CALIPER, MEASURED AT 12" ABOVE GROUND, WITH A MINIMUM HEIGHT OF 7 FEET.
 - APPLY THREE INCHES (3") LAYER OF MULCH ON TOP OF ROOT BALL AFTER PLANTING. KEEP MULCH NINE INCHES (9") FROM BASE OF TREE TRUNK.
 - PRUNE EACH TREE TO CORRECT STRUCTURAL DEFECTS AND REMOVE BROKEN BRANCHES CAUSED BY TRANSPORT AND PLANTING.
 - EVERY OCTOBER APPLY TWO AND A HALF (2 1/2 LB.) POUNDS OF 10-10-10 FERTILIZER PER TEN SQUARE FEET OF AREA BENEATH EACH TREE.

LANDSCAPE CALCULATION:

	QTY.	COMMON NAME	BOTANIC NAME	SIZE/SPACING	SUMMARY	ACTUAL	EQUIV. (%)	REQUIRED
STREET TREES	REQUIRED (183.84/30 OF FRONT)	6 - 3" CALIPER						
	PROVIDED	6 - 3" CALIPER	00 LIVE OAK	QUERCUS VIRGINIANA	3" CALIPER			
			03 TEXAS RED OAK	QUERCUS SHUMARDI	3" CALIPER			
PARKING LOT TREES	REQUIRED (69/18)	4 - 3" CALIPER						
	PROVIDED	07 - 3" CALIPER	00 LIVE OAK	QUERCUS VIRGINIANA	3" CALIPER			
			03 TEXAS RED OAK	QUERCUS SHUMARDI	3" CALIPER			
SCREEN SHRUBS	REQUIRED (183.84/3 LF OF FRONT)	62 - 5 GALLON						
	PROVIDED	146 - 5 GALLON	146 WAX MYRTLE	MYRICA CERIFERA	5 GALLON, 36" O.C.			
TOTAL SHRUBS PROVIDED								
EXIST. TREE FOR REMOVAL	01							
TOTAL LOT AREA:						75,794.40 S.F.		
TOTAL LANDSCAPE AREA						10,091.09 S.F.	14.38% OF THE TOTAL LOT AREA	15% OF THE TOTAL LOT AREA
L.S. AREA FRONT YARD						3,549.85 S.F.	35.18 % TOTAL LANDSCAPE OF THE AREA	

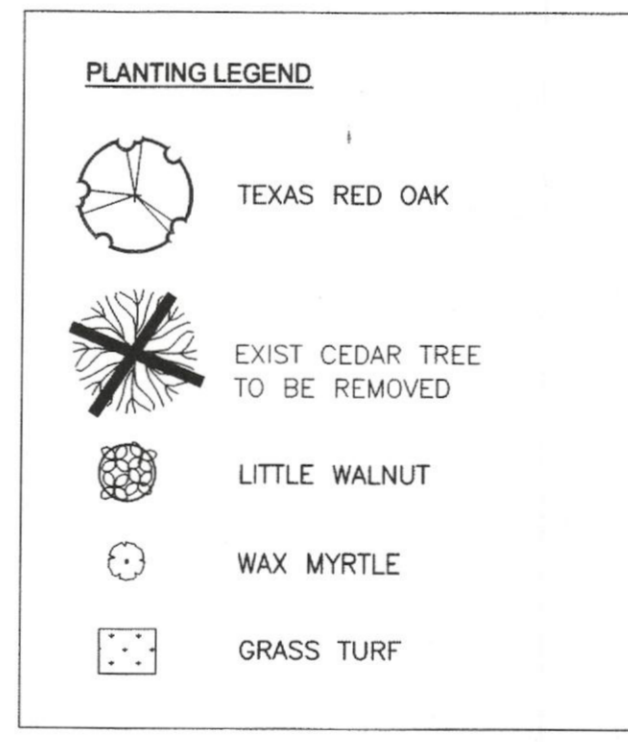

TYPE OF GROUND COVER	AREA
1. BUILDING	11,565.00 S.F.
2. CONCRETE	54,138.91 S.F.
3. VEGETATION	10,091.09 S.F.
TOTAL	75,795.00 S.F.

PLANT LIST :

QTY.	COMMON NAME	BOTANIC NAME	SIZE/SPACING
00	LIVE OAK	QUERCUS VIRGINIANA	3" CALIPER
06	TEXAS RED OAK	QUERCUS TEXANA	3" CALIPER
25	LITTLE WALNUT	JUGLANS MICROCARPA	1" CAL., CANE MIN. 8' HGT.,
412	WAX MYRTLE	MYRICA CERIFERA	5 GALLON, 36" O.C.

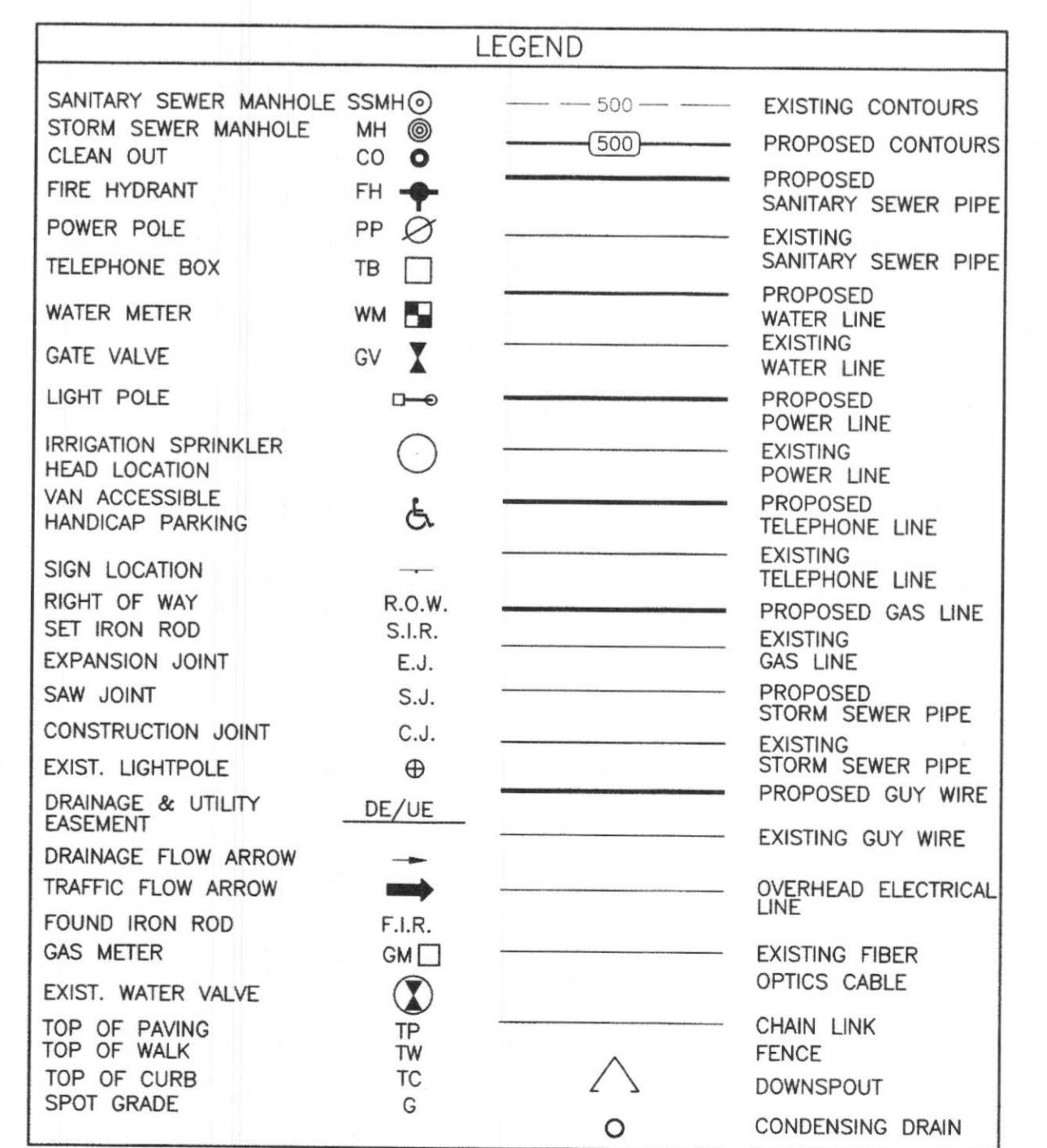

ALEXANDER MARCUS
123 WEST MAIN STREET
SUITE 201
GRAND PRAIRIE
TEXAS 75050
TEL: 469 733 1190
FAX: 469 733 1191

OWNER / DEVELOPER
PASTEM CORP.
PO Box 600433, Dallas, TX 75360
Contact Person: T. DAYALJI
tekdayalji@aol.com

CIVIL ENGINEER:
MLD ENGINEERING SOLUTIONS, INC.
MARTIN L. DE LA ROSA, P.E., F. ASCE
President
2121 W. Airport Freeway, Suite 220 Irving, TX 75062
(972) 258-0484 (972) 672-8347 Fax: (972) 258-1297
email: mdlar6661@aol.com

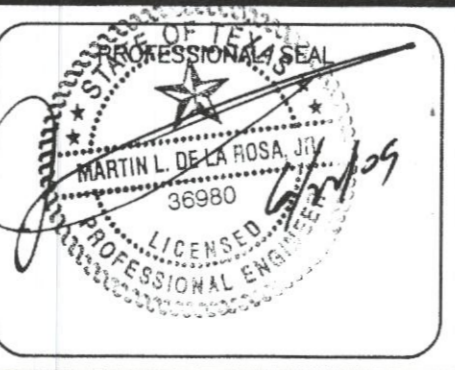

Comfort INN & SUITES
VIGOR WAY,
ROCKWALL, TX 75087
1.74 AC.
BY CHOICE HOTELS

PROJECT NUMBER	DATE	REV. NO.	REVISIONS DESCRIPTION
023-08			
PROJ. TEAM			
DRAWN BY			
CHECKED BY			
ISSUE DATE			
032609			

DRAWING TITLE
**PROPOSED 4 STORY HOTEL
COMFORT INN & SUITES
LANDSCAPE PLAN**

DRAWING NUMBER
C5
PLOT DATE
062209