

NEW FIRE PROTECTION WATER PLAN
SRS Distribution, Inc.
2065 KRISTY LN
CITY OF ROCKWALL
ROCKWALL COUNTY, TEXAS
BODIN INDUSTRIAL TRACT,
LOT 1-E0, ACRES 1

AS BUILT
5/15/2024

RELEASED FOR CONSTRUCTION
 ALL RESPONSIBILITY FOR ADEQUACY OF DESIGN
 REMAINS WITH THE DESIGN ENGINEER. THE CITY
 OF ROCKWALL, IN REVIEWING AND RELEASING
 THESE PLANS FOR CONSTRUCTION, ASSUMES NO
 RESPONSIBILITY FOR ADEQUACY OR ACCURACY OF
 DESIGN.

[Signature] 1/29/24
 CITY DATE

JANUARY 2024

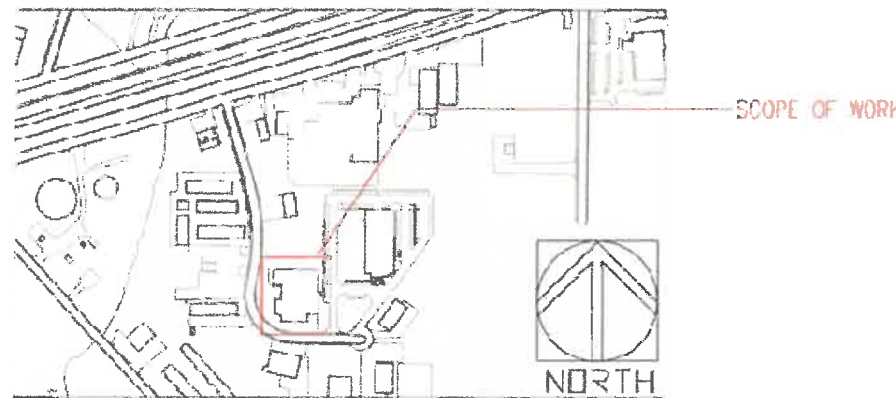

VICINITY MAP
 (NOT TO SCALE)

DRAWING SHEET INDEX

Sheet Number	Sheet Title
C01.00	COVER SHEET
C01.01	WATER PLAN
C01.02	WATER DETAILS
C02.01	PAVING PLAN
C02.02	PAVING DETAILS



CONTRACTOR IS RESPONSIBLE
 TO CONTACT UTILITIES & ONE
 CALL SYSTEM PRIOR TO
 DIGGING

NEW FIRE PROTECTION WATER PLAN
 SRS DISTRIBUTION, INC.
 2065 KRISTY LN

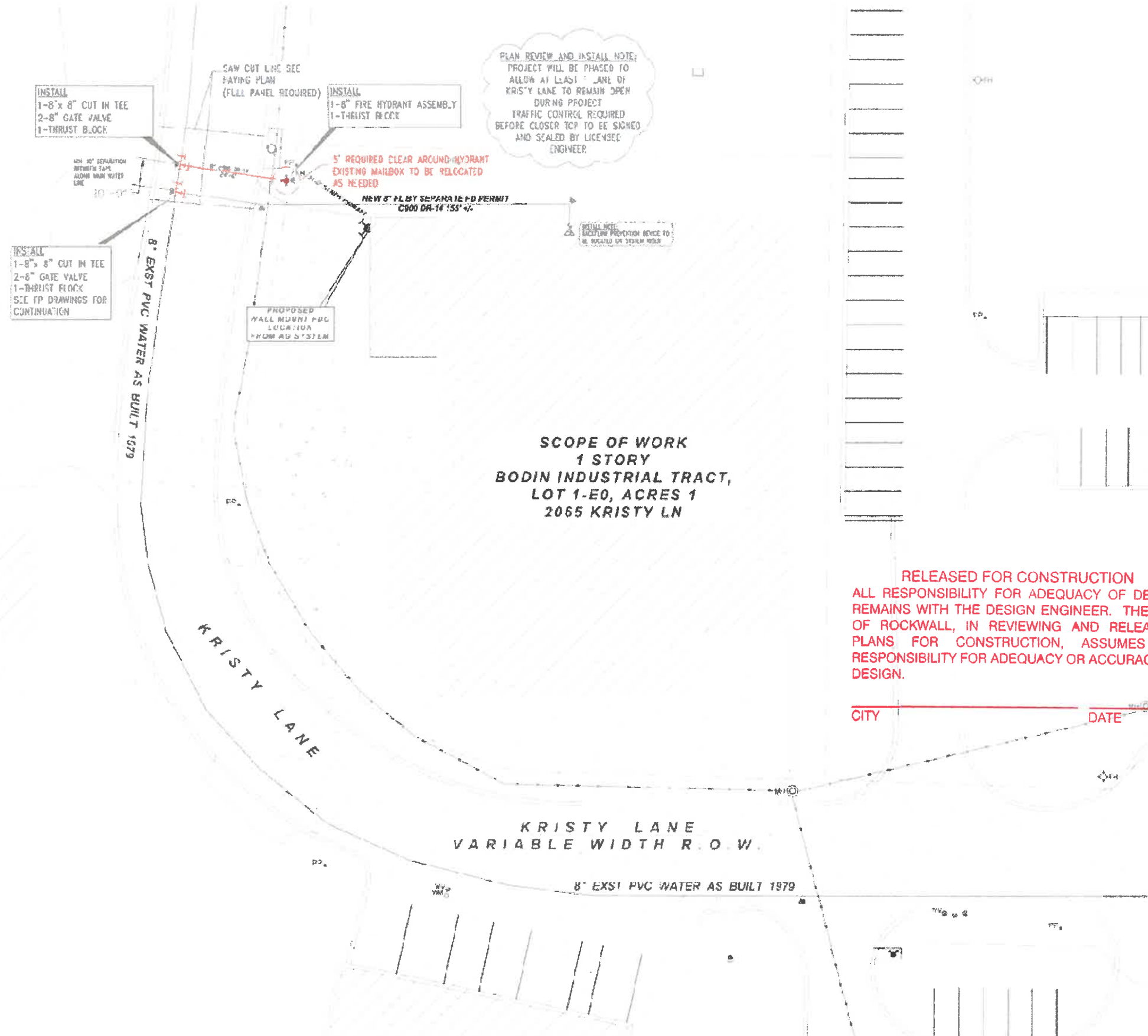

PLAN REVIEW AND INSTALL NOTE:
 PROJECT WILL BE PHASED TO
 ALLOW AT LEAST 1 LANE OF
 KRISTY LANE TO REMAIN OPEN
 DURING PROJECT
 TRAFFIC CONTROL REQUIRED
 BEFORE CLOSER TOP TO BE SIGNED
 AND SEALED BY LICENSEE
 ENGINEER



- LEGEND**
- BO LARD
 - ELECTRIC METER
 - FURN FUL
 - LIGHT STANDAR
 - WATER METER
 - WATER VALVE
 - IRRIGATION CONTROL VALVE
 - FIRE HYDRANT
 - CLEANOUT
 - MANHOLE
 - TRAFFIC SIGNAL CONTROL
 - TRAFFIC SIGNAL HOLE
 - TELEPHONE BOX
 - FLOOD LIGHT
 - FLAG POLE
 - TRAFFIC SIGN
 - 1/2-INCH IRON ROD
 - W/PACKED KCCH" CAP SET
 - CONTROLLING MONUMENT
 - PROPERTY LINE
 - FENCE
 - OVERHEAD UTILITY LINE
 - UNDERGROUND ELECTRIC LINE
 - UNDERGROUND TELEPHONE LINE
 - UNDERGROUND CABLE LINE
 - UNDERGROUND WATER LINE
 - UNDERGROUND SANITARY SEWER LINE
 - FROM FIC LOCATION
 - FROM WATER LINE W/ BEND
 - FROM SANITARY SEWER LINE

RELEASED FOR CONSTRUCTION
 ALL RESPONSIBILITY FOR ADEQUACY OF DESIGN
 REMAINS WITH THE DESIGN ENGINEER. THE CITY
 OF ROCKWALL, IN REVIEWING AND RELEASING
 PLANS FOR CONSTRUCTION, ASSUMES NO
 RESPONSIBILITY FOR ADEQUACY OR ACCURACY OF
 DESIGN.



CITY _____ DATE _____

CONTRACTOR IS RESPONSIBLE
 TO CONTACT UTILITIES & ONE
 CALL SYSTEM PRIOR TO
 DIGGING

COORDINATE!

NOTICE TO CONTRACTOR

THE CONTRACTOR SHALL BE RESPONSIBLE FOR VERIFYING THE LOCATION AND DEPTH OF ALL UTILITIES PRIOR TO ANY EXCAVATION WORK. THE CONTRACTOR SHALL BE RESPONSIBLE FOR OBTAINING ALL NECESSARY PERMITS AND APPROVALS FROM THE CITY OF ROCKWALL AND THE UTILITY COMPANIES. THE CONTRACTOR SHALL BE RESPONSIBLE FOR PROTECTING ALL EXISTING UTILITIES AND STRUCTURES. THE CONTRACTOR SHALL BE RESPONSIBLE FOR RESTORING ALL EXCAVATED AREAS TO ORIGINAL OR BETTER CONDITION. THE CONTRACTOR SHALL BE RESPONSIBLE FOR MAINTAINING TRAFFIC CONTROL DURING CONSTRUCTION. THE CONTRACTOR SHALL BE RESPONSIBLE FOR OBTAINING ALL NECESSARY PERMITS AND APPROVALS FROM THE CITY OF ROCKWALL AND THE UTILITY COMPANIES. THE CONTRACTOR SHALL BE RESPONSIBLE FOR PROTECTING ALL EXISTING UTILITIES AND STRUCTURES. THE CONTRACTOR SHALL BE RESPONSIBLE FOR RESTORING ALL EXCAVATED AREAS TO ORIGINAL OR BETTER CONDITION. THE CONTRACTOR SHALL BE RESPONSIBLE FOR MAINTAINING TRAFFIC CONTROL DURING CONSTRUCTION.

SCOPE OF UNDERGROUND WORK INCLUDES:
 ADVANCED FIRE PROTECTION TO INSTALL NEW 8" W/ 2 NEW 8" TAPS AND NEW
 FIRE HYDRANT FOR NEW BUILDING
 NEW LINE TO BE INTO EXISTING 8" WATER LINE ALL WORK TO BE IN
 CONFORMANCE WITH NFPA 2 AND THE CITY OF ROCKWALL CODES AND
 STANDARDS

AS BUILT
5/15/2024

WATER PLAN

ADVANCED FIRE PROTECTION		ACC ADVANCED	
FLAT NO	ELDG PERMIT NO.	ENGINEER'S TRACKING NOS	
N/A	N/A	N/A	
NEW FL TAP AND FIRE HYDRANT			
SRS DISTRIBUTION WAREHOUSE			
2065 KRISTY LANE Rockwall, TX 75087			
BODIN INDUSTRIAL TRACT LOT 1-E0 ACRES 1			
CITY OF ROCKWALL, ROCKWALL COUNTY, TEXAS			
PREPARED BY	DESIGNED BY	DATE	NUMBER SHEET
JTC	SCG	JAN 6 2024	N/A XXXX C01.01



REVISIONS

REV NO	DATE	DESCRIPTION	BY
	XX-XX-XXXX		XXX

NEW UNDERGROUND FIRELINE TAP AND FIRE HYDRANT

GENERAL NOTES FOR ALL THRUST BLOCKS:

- CONCRETE FOR BLOCKING SHALL BE CLASS "B"
- ALL CALCULATIONS ARE BASED ON INTERNAL PRESSURE OF 200 PSI FOR BUXTLE IRON, P.V.C. AND 150 PSI FOR CONCRETE PIPE
- VOLUMES OF THRUST BLOCKS ARE NET VOLUMES OF CONCRETE TO BE FINISHED THE CORRESPONDING WEIGHT OF THE CONCRETE (CLASS "B") IS EQUAL TO OR GREATER THAN THE VERTICAL COMPONENT OF THE THRUST ON THE VERTICAL BEND.
- WALL THICKNESS (T) ASSUMED HERE FOR ESTIMATING PURPOSES ONLY
- POUR CONCRETE FOR BLOCK AGAINST UNDISTURBED EARTH.
- DIMENSIONS MAY BE VARIED AS REQUIRED BY FIELD CONDITIONS WHERE AND AS DIRECTED BY THE ENGINEER. THE VOLUME OF CONCRETE SHALL BE 1.0 SF LESS THAN SHOWN HERE.
- THE SOIL BEARING CAPACITIES ARE BASED ON 1000 LBS./SF. IN SOIL AND 2000 LBS./SF. IN ROCK.
- USE POLYETHYLENE WRAP OR EQUAL BETWEEN CONCRETE MID BEND, FEET, OR PLUG TO PREVENT THE CONCRETE FROM STICKING TO IT.
- CONCRETE SHALL NOT EXTEND BEYOND JOINTS.

GENERAL NOTES FOR ALL THRUST BLOCKS:

- CONCRETE FOR BLOCKING SHALL BE CLASS "B"
- ALL CALCULATIONS ARE BASED ON INTERNAL PRESSURE OF 200 PSI FOR BUXTLE IRON, P.V.C. AND 150 PSI FOR CONCRETE PIPE
- VOLUMES OF THRUST BLOCKS ARE NET VOLUMES OF CONCRETE TO BE FINISHED THE CORRESPONDING WEIGHT OF THE CONCRETE (CLASS "B") IS EQUAL TO OR GREATER THAN THE VERTICAL COMPONENT OF THE THRUST ON THE VERTICAL BEND.
- WALL THICKNESS (T) ASSUMED HERE FOR ESTIMATING PURPOSES ONLY
- POUR CONCRETE FOR BLOCK AGAINST UNDISTURBED EARTH.
- DIMENSIONS MAY BE VARIED AS REQUIRED BY FIELD CONDITIONS WHERE AND AS DIRECTED BY THE ENGINEER. THE VOLUME OF CONCRETE SHALL BE 1.0 SF LESS THAN SHOWN HERE.
- THE SOIL BEARING CAPACITIES ARE BASED ON 1000 LBS./SF. IN SOIL AND 2000 LBS./SF. IN ROCK.
- USE POLYETHYLENE WRAP OR EQUAL BETWEEN CONCRETE MID BEND, FEET, OR PLUG TO PREVENT THE CONCRETE FROM STICKING TO IT.
- CONCRETE SHALL NOT EXTEND BEYOND JOINTS.

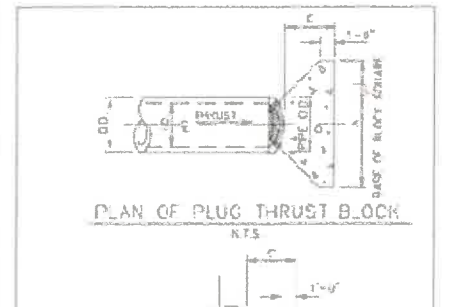
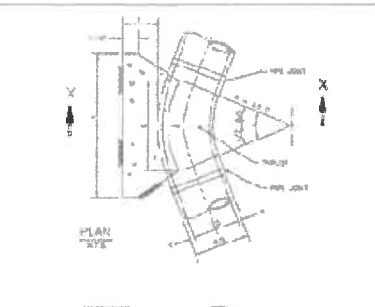
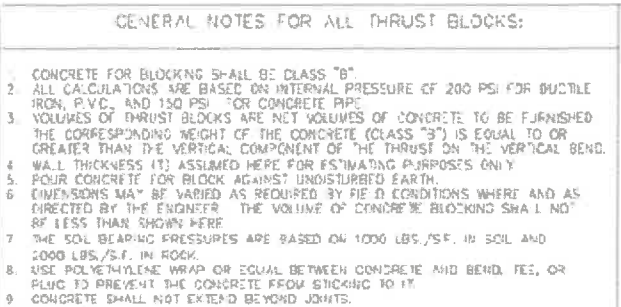

GENERAL NOTES FOR ALL THRUST BLOCKS:

- CONCRETE FOR BLOCKING SHALL BE CLASS "B"
- ALL CALCULATIONS ARE BASED ON INTERNAL PRESSURE OF 200 PSI FOR BUXTLE IRON, P.V.C. AND 150 PSI FOR CONCRETE PIPE
- VOLUMES OF THRUST BLOCKS ARE NET VOLUMES OF CONCRETE TO BE FINISHED THE CORRESPONDING WEIGHT OF THE CONCRETE (CLASS "B") IS EQUAL TO OR GREATER THAN THE VERTICAL COMPONENT OF THE THRUST ON THE VERTICAL BEND.
- WALL THICKNESS (T) ASSUMED HERE FOR ESTIMATING PURPOSES ONLY
- POUR CONCRETE FOR BLOCK AGAINST UNDISTURBED EARTH.
- DIMENSIONS MAY BE VARIED AS REQUIRED BY FIELD CONDITIONS WHERE AND AS DIRECTED BY THE ENGINEER. THE VOLUME OF CONCRETE SHALL BE 1.0 SF LESS THAN SHOWN HERE.
- THE SOIL BEARING CAPACITIES ARE BASED ON 1000 LBS./SF. IN SOIL AND 2000 LBS./SF. IN ROCK.
- USE POLYETHYLENE WRAP OR EQUAL BETWEEN CONCRETE MID BEND, FEET, OR PLUG TO PREVENT THE CONCRETE FROM STICKING TO IT.
- CONCRETE SHALL NOT EXTEND BEYOND JOINTS.

GENERAL NOTES FOR ALL THRUST BLOCKS:

- CONCRETE FOR BLOCKING SHALL BE CLASS "B"
- ALL CALCULATIONS ARE BASED ON INTERNAL PRESSURE OF 200 PSI FOR BUXTLE IRON, P.V.C. AND 150 PSI FOR CONCRETE PIPE
- VOLUMES OF THRUST BLOCKS ARE NET VOLUMES OF CONCRETE TO BE FINISHED THE CORRESPONDING WEIGHT OF THE CONCRETE (CLASS "B") IS EQUAL TO OR GREATER THAN THE VERTICAL COMPONENT OF THE THRUST ON THE VERTICAL BEND.
- WALL THICKNESS (T) ASSUMED HERE FOR ESTIMATING PURPOSES ONLY
- POUR CONCRETE FOR BLOCK AGAINST UNDISTURBED EARTH.
- DIMENSIONS MAY BE VARIED AS REQUIRED BY FIELD CONDITIONS WHERE AND AS DIRECTED BY THE ENGINEER. THE VOLUME OF CONCRETE SHALL BE 1.0 SF LESS THAN SHOWN HERE.
- THE SOIL BEARING CAPACITIES ARE BASED ON 1000 LBS./SF. IN SOIL AND 2000 LBS./SF. IN ROCK.
- USE POLYETHYLENE WRAP OR EQUAL BETWEEN CONCRETE MID BEND, FEET, OR PLUG TO PREVENT THE CONCRETE FROM STICKING TO IT.
- CONCRETE SHALL NOT EXTEND BEYOND JOINTS.

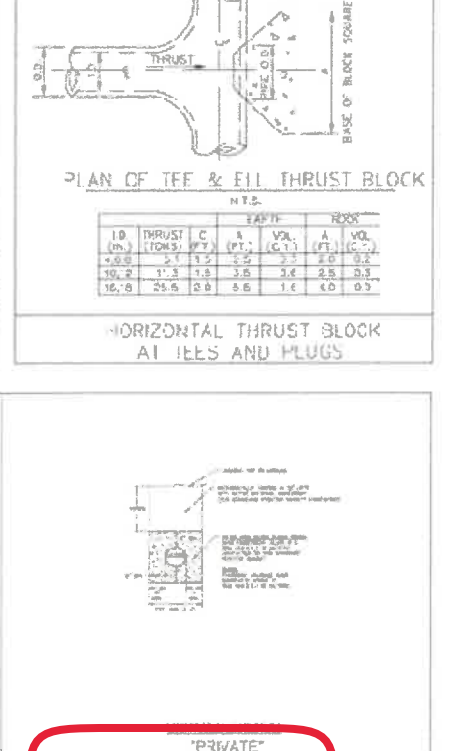
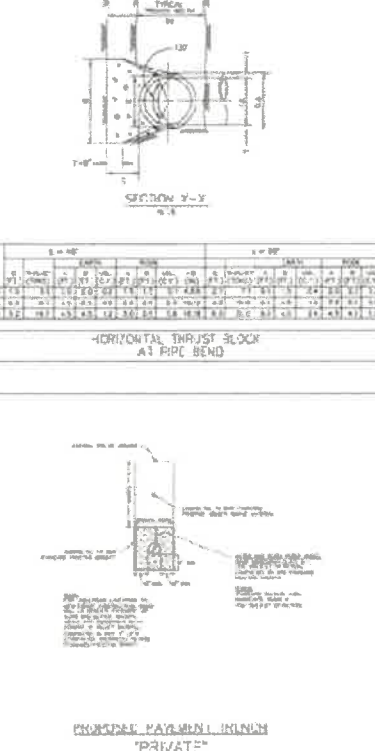
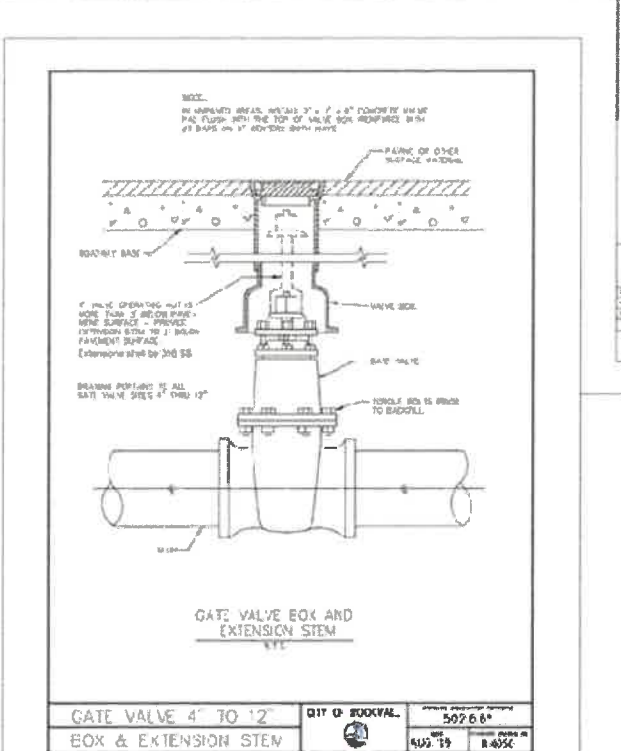

GENERAL NOTES FOR ALL THRUST BLOCKS:

- CONCRETE FOR BLOCKING SHALL BE CLASS "B"
- ALL CALCULATIONS ARE BASED ON INTERNAL PRESSURE OF 200 PSI FOR BUXTLE IRON, P.V.C. AND 150 PSI FOR CONCRETE PIPE
- VOLUMES OF THRUST BLOCKS ARE NET VOLUMES OF CONCRETE TO BE FINISHED THE CORRESPONDING WEIGHT OF THE CONCRETE (CLASS "B") IS EQUAL TO OR GREATER THAN THE VERTICAL COMPONENT OF THE THRUST ON THE VERTICAL BEND.
- WALL THICKNESS (T) ASSUMED HERE FOR ESTIMATING PURPOSES ONLY
- POUR CONCRETE FOR BLOCK AGAINST UNDISTURBED EARTH.
- DIMENSIONS MAY BE VARIED AS REQUIRED BY FIELD CONDITIONS WHERE AND AS DIRECTED BY THE ENGINEER. THE VOLUME OF CONCRETE SHALL BE 1.0 SF LESS THAN SHOWN HERE.
- THE SOIL BEARING CAPACITIES ARE BASED ON 1000 LBS./SF. IN SOIL AND 2000 LBS./SF. IN ROCK.
- USE POLYETHYLENE WRAP OR EQUAL BETWEEN CONCRETE MID BEND, FEET, OR PLUG TO PREVENT THE CONCRETE FROM STICKING TO IT.
- CONCRETE SHALL NOT EXTEND BEYOND JOINTS.

GENERAL NOTES FOR ALL THRUST BLOCKS:

- CONCRETE FOR BLOCKING SHALL BE CLASS "B"
- ALL CALCULATIONS ARE BASED ON INTERNAL PRESSURE OF 200 PSI FOR BUXTLE IRON, P.V.C. AND 150 PSI FOR CONCRETE PIPE
- VOLUMES OF THRUST BLOCKS ARE NET VOLUMES OF CONCRETE TO BE FINISHED THE CORRESPONDING WEIGHT OF THE CONCRETE (CLASS "B") IS EQUAL TO OR GREATER THAN THE VERTICAL COMPONENT OF THE THRUST ON THE VERTICAL BEND.
- WALL THICKNESS (T) ASSUMED HERE FOR ESTIMATING PURPOSES ONLY
- POUR CONCRETE FOR BLOCK AGAINST UNDISTURBED EARTH.
- DIMENSIONS MAY BE VARIED AS REQUIRED BY FIELD CONDITIONS WHERE AND AS DIRECTED BY THE ENGINEER. THE VOLUME OF CONCRETE SHALL BE 1.0 SF LESS THAN SHOWN HERE.
- THE SOIL BEARING CAPACITIES ARE BASED ON 1000 LBS./SF. IN SOIL AND 2000 LBS./SF. IN ROCK.
- USE POLYETHYLENE WRAP OR EQUAL BETWEEN CONCRETE MID BEND, FEET, OR PLUG TO PREVENT THE CONCRETE FROM STICKING TO IT.
- CONCRETE SHALL NOT EXTEND BEYOND JOINTS.

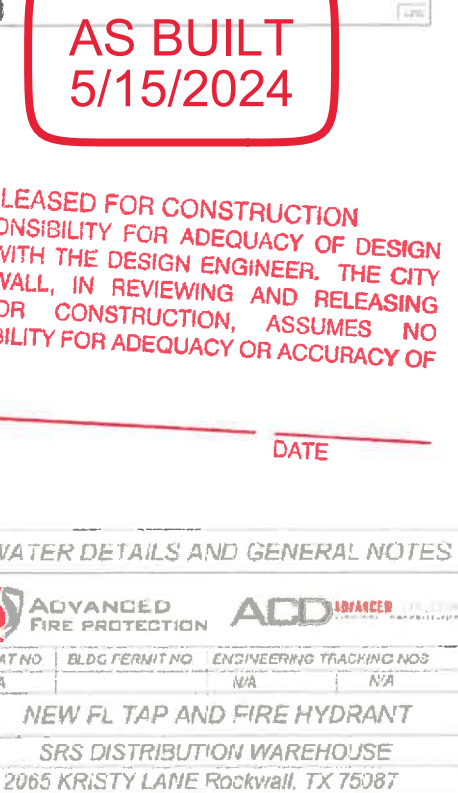
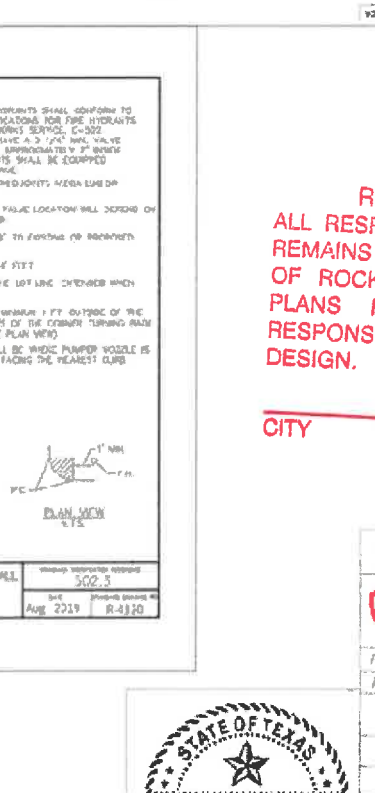
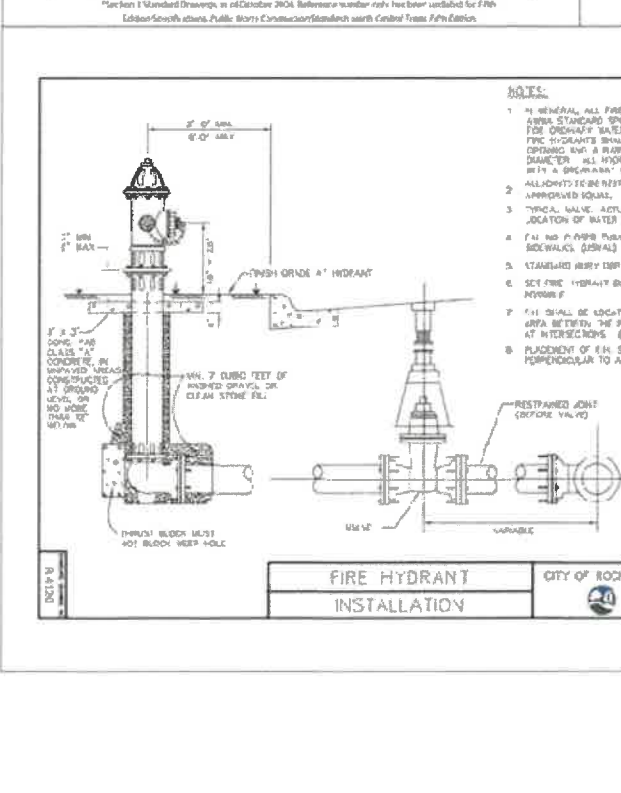

AS BUILT 5/15/2024

RELEASED FOR CONSTRUCTION
ALL RESPONSIBILITY FOR ADEQUACY OF DESIGN
REMAINS WITH THE DESIGN ENGINEER. THE CITY
OF ROCKWALL, IN REVIEWING AND RELEASING
PLANS FOR CONSTRUCTION, ASSUMES NO
RESPONSIBILITY FOR ADEQUACY OR ACCURACY OF
DESIGN.

CITY _____ DATE _____

WATER DETAILS AND GENERAL NOTES

PLAT NO	BLDG FERNIT NO	ENGINEERING TRACKING NOS
N/A	N/A	N/A
NEW FL TAP AND FIRE HYDRANT		
SRS DISTRIBUTION WAREHOUSE		
2065 KRISTY LANE Rockwall, TX 75087		
EODIN INDUSTRIAL TRACT LOT 1-EO ACRES 1		
CITY OF ROCKWALL, ROCKWALL COUNTY, TEXAS		
REVISED BY	DATE	DESCRIPTION
JTC	05/15/2024	N/A XXXX C01.01



REVISIONS

REV NO	DATE	DESCRIPTION	BY
XX-00-XXXX			XXX

GENERAL CONSTRUCTION NOTES
 Sheet 4 of 2
 CIVIL ENGINEER
 CITY OF ROCKWALL
 2005 E. South
 Rockwall, Texas 75087
 P: (972) 971-7748
 F: (972) 971-7748

PLAN REVIEW AND INSTALL NOTE:
 PROJECT WILL BE PHASED TO ALLOW AT LEAST 1 LANE OF KRISTY LANE TO REMAIN OPEN DURING PROJECT. TRAFFIC CONTROL REQUIRED BEFORE CLOSER TOP TO BE SIGNED AND SEALED BY LICENSED ENGINEER.

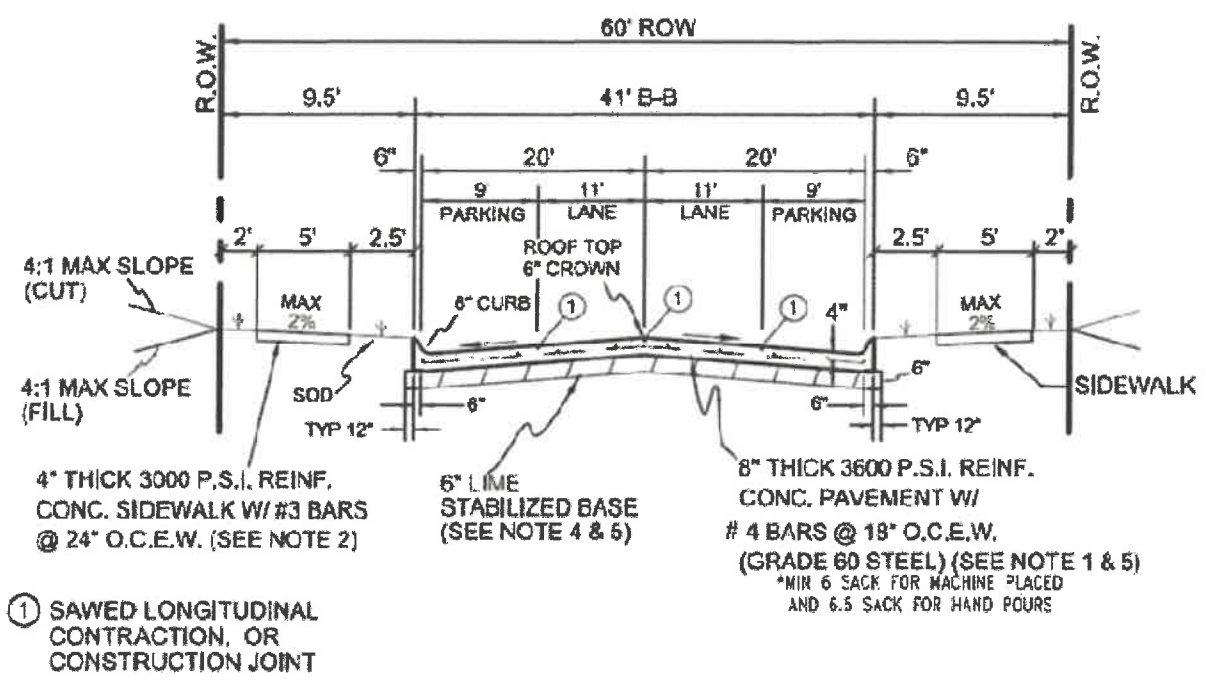
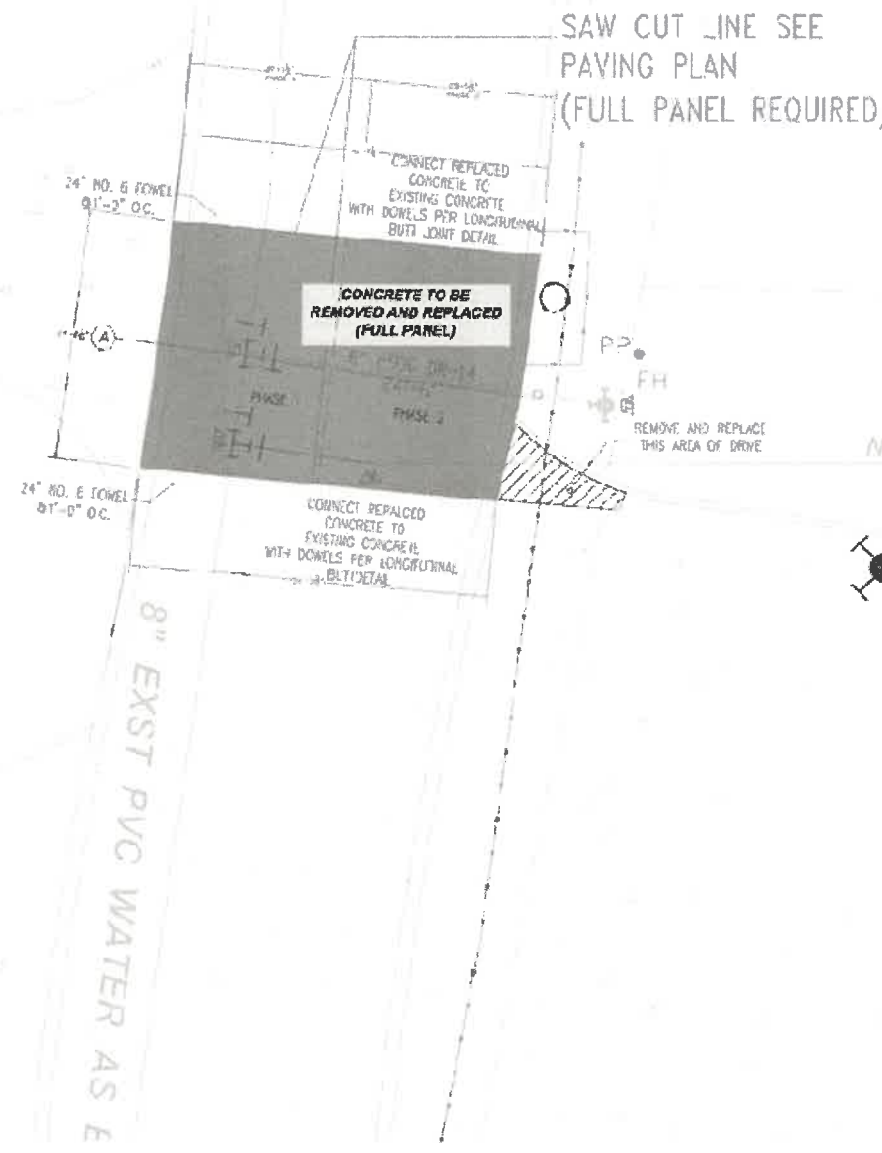

PAVING SECTION "A"
 N.T.S.

AS BUILT
5/15/2024



CONTRACTOR IS RESPONSIBLE TO CONTACT UTILITIES & ONE CALL SYSTEM PRIOR TO DIGGING.



SCOPE OF UNDERGROUND WORK INCLUDES:
 ADVANCED FIRE PROTECTION TO INSTALL NEW 8" WL 2 NEW 8" TAPS AND NEW FIRE HYDRANT FOR NEW BUILDING.
 NEW LINE TO BE TIED INTO EXISTING 8" WATER LINE ALL WORK TO BE IN CONFORMANCE WITH NFPA 24 AND THE CITY OF ROCKWALL CODES AND STANDARDS.

RELEASED FOR CONSTRUCTION
 ALL RESPONSIBILITY FOR ADEQUACY OF DESIGN REMAINS WITH THE DESIGN ENGINEER. THE CITY OF ROCKWALL, IN REVIEWING AND RELEASING PLANS FOR CONSTRUCTION, ASSUMES NO RESPONSIBILITY FOR ADEQUACY OR ACCURACY OF DESIGN.

CITY _____ DATE _____

PAVEMENT REMOVAL AND REPLACEMENT

REVISIONS			
REV NO	DATE	DESCRIPTION	BY
XX	0-2-2024		XXX



PAVING PLAN

ADVANCED FIRE PROTECTION **ACD** ADVANCED CONSTRUCTION DESIGN

PLAT NO	BLDG PERMIT NO	ENGINEERING TRACKING NOS
N/A	N/A	N/A

NEW FL TAP AND FIRE HYDRANT
SRS DISTRIBUTION WAREHOUSE
 2065 KRISTY LANE Rockwall, TX 75087
 BODIN INDUSTRIAL TRACT LOT 1-ED. ACRES 1
 CITY OF ROCKWALL, ROCKWALL COUNTY, TEXAS

REVIEW BY	DATE	DATE	NO.	NUMBER	DIFF
JTC	SCC	JAN 6 2024	N/A	XXXX	C01.01

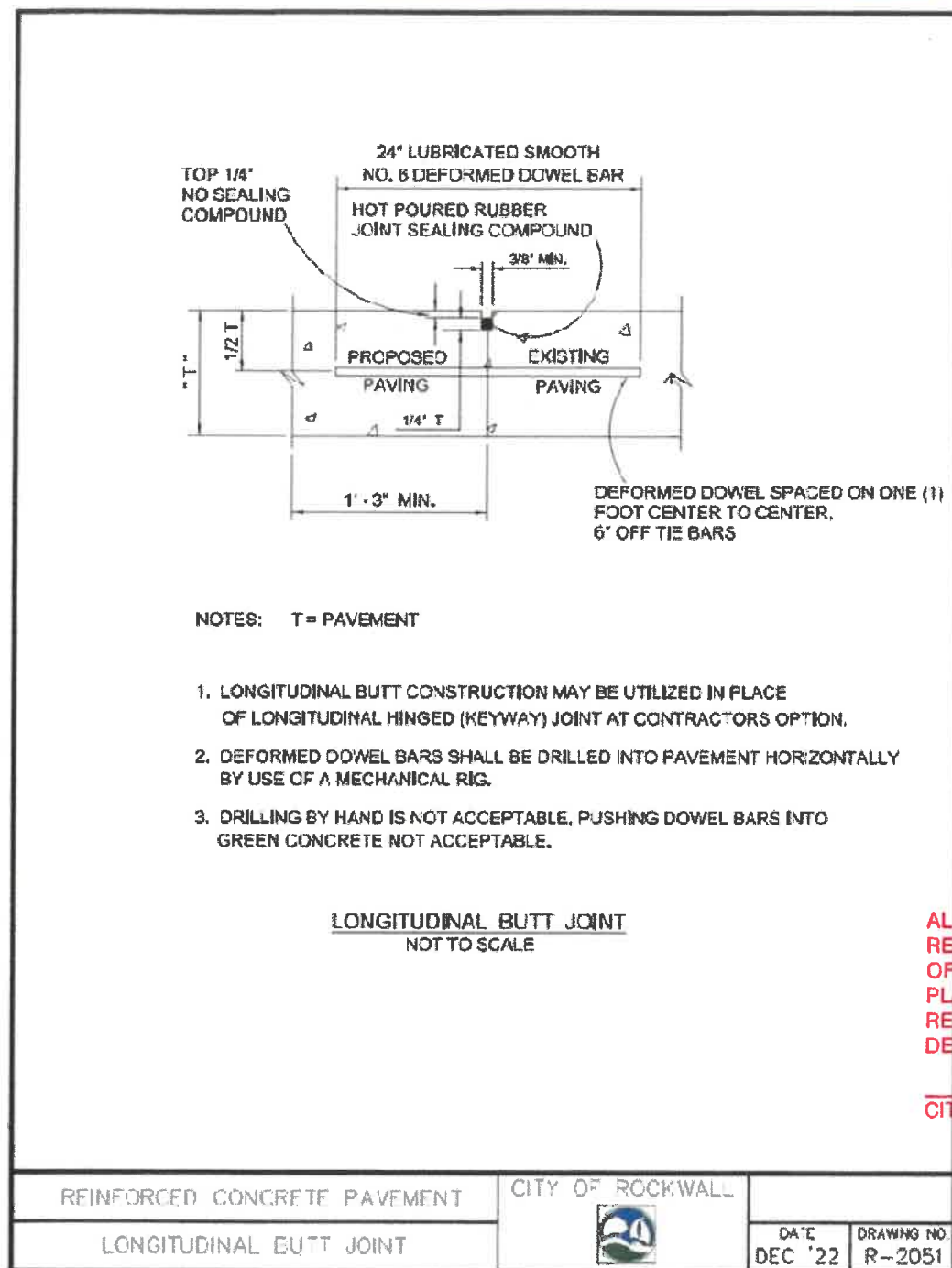
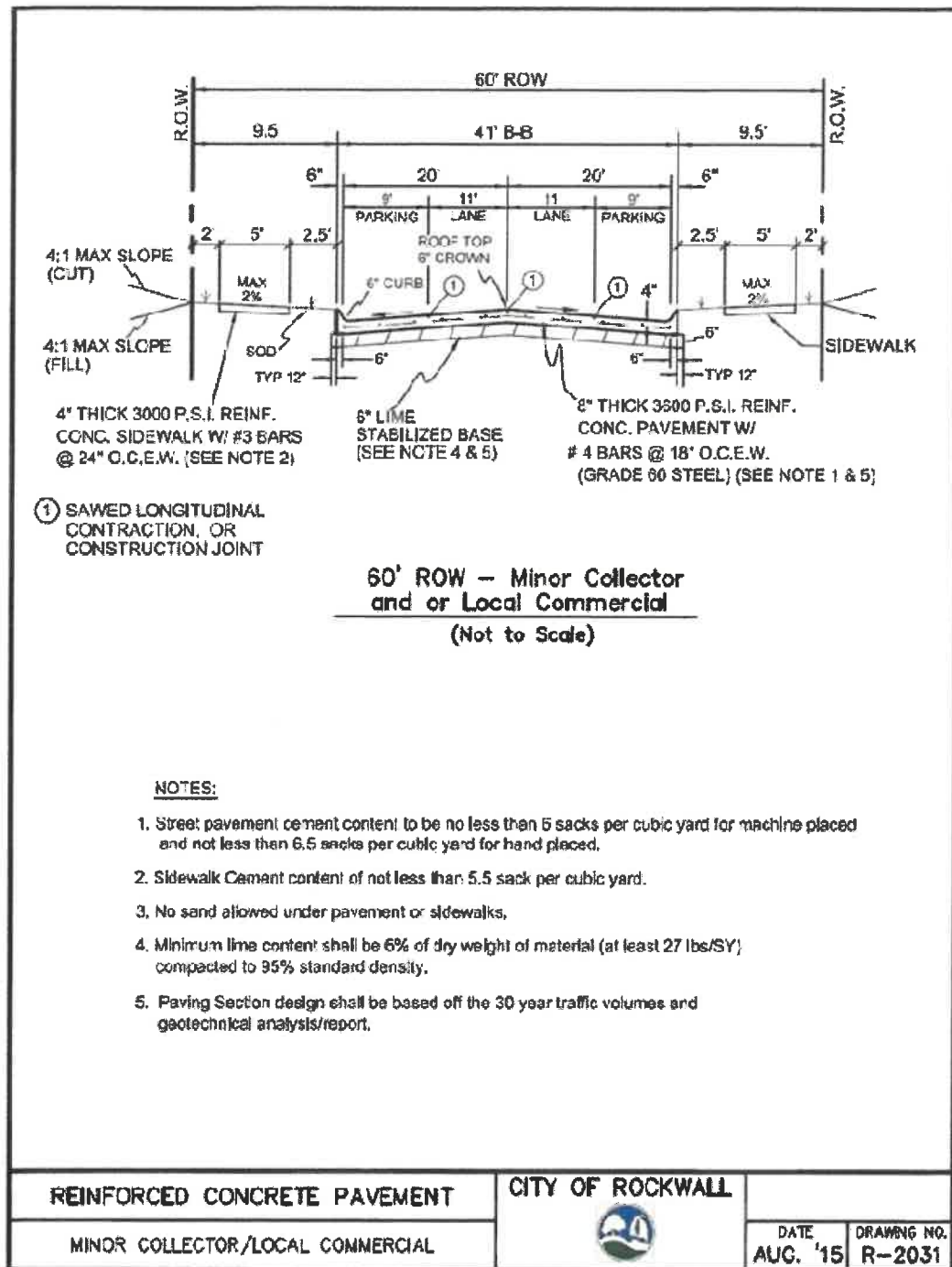

RELEASED FOR CONSTRUCTION
 ALL RESPONSIBILITY FOR ADEQUACY OF DESIGN REMAINS WITH THE DESIGN ENGINEER. THE CITY OF ROCKWALL, IN REVIEWING AND RELEASING PLANS FOR CONSTRUCTION, ASSUMES NO RESPONSIBILITY FOR ADEQUACY OR ACCURACY OF DESIGN.

CITY _____ DATE _____

AS BUILT
5/15/2024

REV. NO.	DATE	DESCRIPTION	BY
	XX-XX-XXXX		XXX

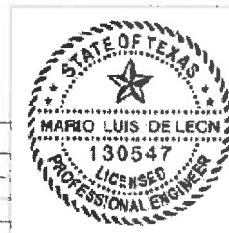

PAVING DETAILS						
PLAT NO.	BLDG PERMIT NO.	ENGINEERING TRACKING NOS.				
N/A	N/A	N/A				
NEW FL TAP AND FIRE HYDRANT						
SRS DISTRIBUTION WAREHOUSE						
2065 KRISTY LANE Rockwall, TX 75087						
BODIN INDUSTRIAL TRACT LOT 1-E0 ACRES 1						
CITY OF ROCKWALL, ROCKWALL COUNTY, TEXAS						
REVISED BY	APPROVED BY	DATE	FILE #	CLAMP #	CHART	
JTC	SCG	JAN 4 2024	N/A	XXXX	C01.01	