

GRAPHIC SCALE



(IN FEET)
1 inch = 100 ft.

LINE	LENGTH	BEARING
L1	11.42'	S89°10'21"W
L2	46.18'	N00°49'39"W
L3	28.99'	N79°37'53"E
L4	44.95'	N67°57'29"E
L5	42.45'	N87°39'24"E
L6	24.23'	S45°55'56"W

CURVE	LENGTH	RADIUS	CURVE TABLE		
			TANGENT	CH BRG	CH DIST
C1	80.29	50.00	51.79	S46°18'18"E	71.94
C2	136.81	500.00	68.83	N07°28'01"E	136.38
C3	34.26	250.00	17.16	S88°25'03"E	34.23
C4	349.33	668.50	178.75	S77°20'25"E	345.37
C5	78.57	50.00	50.03	N42°40'23"E	70.73
C6	418.37	265.00	267.12	N45°35'59"W	376.25
C7	348.15	225.00	219.78	N45°09'21"W	314.45
C8	18.98	700.00	9.49	N80°24'28"E	18.97
C9	171.90	500.00	86.81	N12°11'34"W	171.06
C10	163.85	225.00	85.75	N66°47'40"E	160.25
C11	168.75	225.00	88.57	S67°25'05"W	164.82
C12	110.00	275.00	55.75	N79°38'13"W	109.27

15,904 AC.
ROCKWALL ELEMENTARY SCHOOL NO. 9
CABINET E, SLIDE 161
P.R.R.C.T.

N. BUTLER SURVEY, ABSTRACT NO. 21
A. HANNA SURVEY, ABSTRACT NO. 98

J.H.B. JONES SURVEY, ABSTRACT NO. 124

FRANK R. MILLER
VOLUME 83, PAGE 11
D.R.R.C.T.

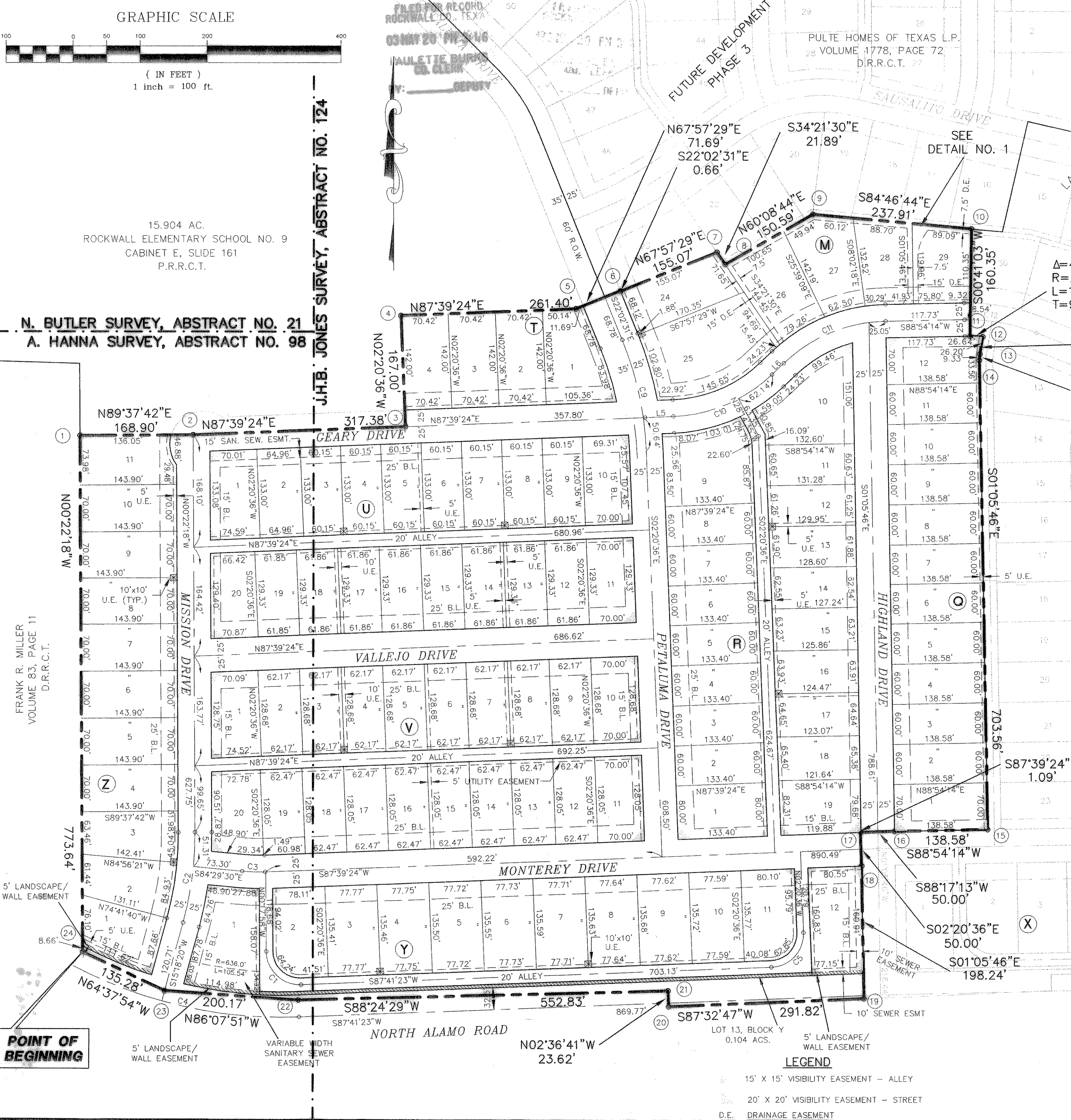

Δ=4°19'27"
R=250.00
L=18.87
T=9.44

R=50.00'
L=9.33'
T=4.68'
D=10°41'34"

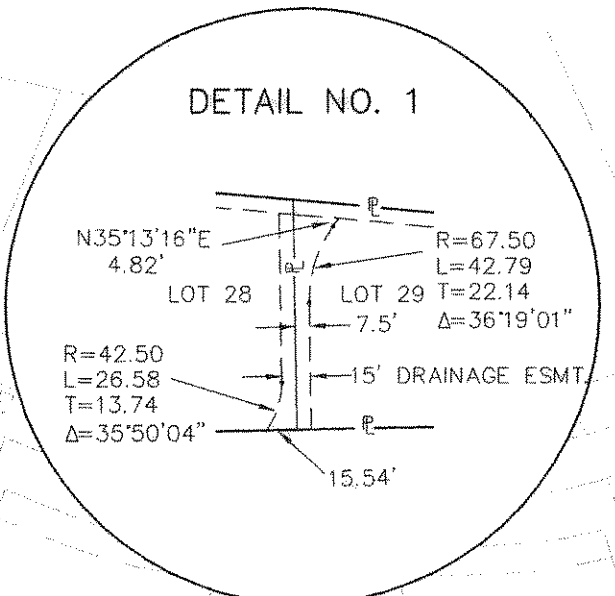

MONUMENTS BASED ON THE CITY OF ROCKWALL CONTROL

#	NORTHING	EASTING
1	N 7033213.5911	E 2591266.8992
2	N 7033214.6869	E 2591435.7956
3	N 7033227.6637	E 2591752.9078
4	N 7033394.5196	E 2591746.0795
5	N 7033405.2080	E 2592007.2601
6	N 7033432.1110	E 2592073.7072
7	N 7033489.6978	E 2592217.6860
8	N 7033471.6256	E 2592230.0410
9	N 7033546.5898	E 2592360.6482
10	N 7033524.9398	E 2592597.5757
11	N 7033364.6007	E 2592595.6608
12	N 7033363.6640	E 2592614.5006
13	N 7033337.8261	E 2592610.1319
14	N 7033328.5340	E 2592609.4413
15	N 7032625.1070	E 2592622.8984
16	N 7032622.4563	E 2592484.3416
17	N 7032620.9171	E 2592433.2732
18	N 7032570.9589	E 2592435.3176
19	N 7032372.7532	E 2592439.1095
20	N 7032360.2603	E 2592147.5603
21	N 7032383.8587	E 2592146.4840
22	N 7032366.5002	E 2591593.8638
23	N 7032382.0068	E 2591394.1572
24	N 7032439.9670	E 2591271.9184

OWNER/DEVELOPER
PULTE HOMES OF TEXAS, L.P.
1431 GREENWAY DRIVE, SUITE 700
IRVING, TEXAS 75038
(972) 751-1499

ENGINEER/SURVEYOR
DOUPHRADE & ASSOCIATES, INC.
P.O. BOX 1336
ROCKWALL, TEXAS 75087
(972) 771-9004
E 303-304

FINAL PLAT
29.899 AC. - 104 LOTS
LAKEVIEW SUMMIT
PHASE 2
J.H.B. JONES SURVEY, ABSTRACT NO. 124
A. HANNA SURVEY, ABSTRACT NO. 98
CITY OF ROCKWALL
ROCKWALL COUNTY, TEXAS

PROJECT: 9919-2PLT
DATE: MAY 2002
SCALE: 1"=100'
DRAWN: D.L.B.
CHK'D: W.L.D.

DOUPHRADE & ASSOCIATES, INC.
ENGINEERING • PROJECT MANAGEMENT • SURVEYING
P.O. BOX 1336 ROCKWALL, TEXAS 75087
PHONE: (972)771-9004 FAX: (972)771-9005

SHEET 1 OF 2

LEGEND
15' X 15' VISIBILITY EASEMENT - ALLEY
20' X 20' VISIBILITY EASEMENT - STREET
D.E. DRAINAGE EASEMENT