

THE SEAL APPEARING ON THIS DOCUMENT WAS AUTHORIZED BY M.C. DOUPHRETE, TEXAS P.E. LICENSE NO. 00102, ON OCTOBER 26, 2014. DATE: OCT. 4, 2014.

DOUPHRETE & ASSOCIATES, INC.
 ENGINEERING • PROJECT MANAGEMENT • SURVEYING
 2235 RIDGE RD., # 200 ROCKWALL, TEXAS 75087
 PHONE: (972)771-9004 FAX: (972)771-9005

EROSION CONTROL DETAILS
 LAKEVIEW SUMMIT, PHASE 4
 CITY OF ROCKWALL
 ROCKWALL COUNTY, TEXAS

REVISION
 SAH
 CHECKED
 DLB.
 DRAWN
 10/14
 DATE
 9919-4 ERO2
 PROJECT

STANDARDS FOR SILT FENCE

DEFINITION

TEMPORARY BARRIER FENCE MADE OF BURLAP OR POLYPROPYLENE MATERIAL WHICH IS WATER PERMEABLE BUT WILL TRAP WATER BORNE SEDIMENT.

PURPOSE

TO INTERCEPT AND DETAIN WATER BORNE SEDIMENT FROM UNPROTECTED AREAS OF LIMITED EXTENT.

CONDITIONS WHERE PRACTICE APPLIES

SILT FENCE IS USED DURING THE PERIOD OF CONSTRUCTION NEAR THE PERIMETER OF A DISTURBED AREA TO INTERCEPT SEDIMENT WHILE ALLOWING WATER TO PERCOLATE THROUGH. THIS FENCE SHALL REMAIN IN PLACE UNTIL THE DISTURBED AREA IS PERMANENTLY STABILIZED. SILT FENCE SHOULD NOT BE USED WHERE THERE IS A CONCENTRATION OF WATER IN A CHANNEL OR OTHER DRAINAGE WAY.

DESIGN CRITERIA

SILT FENCE IS CONSTRUCTED NEAR THE PERIMETER OF A DISTURBED SITE WITHIN THE DEVELOPING AREA. IT IS NOT TO BE CONSTRUCTED OUTSIDE THE PROPERTY LINES WITHOUT OBTAINING A LETTER OF PERMISSION FROM THE AFFECTED ADJACENT PROPERTY OWNERS.

A DESIGN IS NOT REQUIRED FOR THE INSTALLATION OF THE SILT FENCE. HOWEVER, THE FOLLOWING CRITERIA SHALL BE OBSERVED:

- DRAINAGE AREA - LESS THAN TWO ACRES
- HEIGHT - 30 INCHES MINIMUM HEIGHT MEASURED FROM EXISTING OR GRADED GROUND.
- MATERIAL - BURLAP, POLYPROPYLENE FABRIC, OR NYLON REINFORCED WITH POLYESTER NETTING. THE MULLEN BURST STRENGTH SHALL BE GREATER THAN 150 PSI. THE EDGES SHALL BE TREATED TO PREVENT UNRAVELING.
- SUPPORT - STEEL FENCE POSTS SPACED A MAXIMUM OF 8 FEET APART. WOVEN WIRE WILL BE USED TO SUPPORT THE MATERIAL.

OUTLET

SILT FENCE SHALL BE PLACED AND CONSTRUCTED IN SUCH A MANNER THAT RUNOFF FROM A DISTURBED SURFACE OR EXPOSED UPLAND AREA SHALL BE INTERCEPTED, SEDIMENT TRAPPED, AND THE SURFACE RUNOFF ALLOWED TO PERCOLATE THROUGH THE STRUCTURE.

SILT FENCE SHALL BE PLACED IN SUCH A MANNER THAT SURFACE RUNOFF WHICH PERCOLATES THROUGH WILL FLOW ONTO AN UNDISTURBED STABILIZED AREA OR STABILIZED OUTLET.

" T " POST WITH WIRE MESH SHALL BE USED IF SLOPE TOWARDS FENCE IS GREATER THAN 6%.

EROSION CONTROL GENERAL NOTES

1. STEEL POSTS WHICH SUPPORT THE SILT FENCE SHALL BE INSTALLED ON A SLIGHT ANGLE TOWARD THE ANTICIPATED RUNOFF SOURCE.
2. THE TOE OF THE SILT FENCE SHALL BE TRENCHED IN WITH A SPADE OR MECHANICAL TRENCHER SO THAT THE DOWNSLOPE FACE OF THE TRENCH IS FLAT AND PERPENDICULAR TO THE LINE OF FLOW.
3. THE TRENCH SHOULD BE A MINIMUM OF 4 INCHES DEEP AND 4 INCHES WIDE TO ALLOW FOR THE SILT FENCE TO BE LAID IN THE GROUND AND BACKFILLED.
4. SILT FENCE SHOULD BE SECURELY FASTENED TO EACH STEEL SUPPORT POST.
5. INSPECTION SHALL BE FREQUENT AND REPAIR OR REPLACEMENT SHALL BE MADE PROMPTLY AS NEEDED.
6. SILT FENCE SHALL BE REMOVED WHEN IT HAS SERVED ITS USEFULNESS, SO AS NOT TO BLOCK OR IMPEDE STORM FLOW OR DRAINAGE.
7. SEDIMENT TRAPPED BY THIS PRACTICE SHALL BE DISPOSED OF IN AN APPROVED SITE IN A MANNER THAT WILL NOT CONTRIBUTE TO ADDITIONAL SILTATION.
8. ACCUMULATED SILT SHALL BE REMOVED WHEN IT REACHES A DEPTH OF 6 INCHES AND DISPOSED OF IN AN APPROVED SPOIL SITE OR AS IN NO. 7 ABOVE.
9. EROSION PROTECTION WILL BE DELETED OR ADDED PER THE CITY OF ROCKWALL OR OTHER GROWTH TO PREVENT EROSION.
10. THE CONTRACTOR SHALL COMPLY WITH ALL APPLICABLE FEDERAL, STATE, AND LOCAL EROSION, CONSERVATION, AND SILTATION ORDINANCES. THE CONTRACTOR SHALL REMOVE ALL TEMPORARY EROSION CONTROL DEVICES UPON COMPLETION OF PERMANENT DRAINAGE FACILITIES AND THE ESTABLISHMENT OF A STAND OF GRASS.
11. ALL SEEDING, FERTILIZATION AND WATERING OF DISTURBED AREAS WILL BE THE RESPONSIBILITY OF THE GRADING CONTRACTOR. MUST BE 75% - 80% COVERAGE AND A MINIMUM OF 1" IN HEIGHT BEFORE CITY ACCEPTANCE.
12. AFTER FINAL LOT GRADING AND BEFORE CITY ACCEPTANCE, SILT FENCE MUST BE INSTALLED AT THE BACK OF CURB (FOR STREETS) AND EDGE OF PAVING (FOR ALLEYS).
13. DETENTION POND SIDES AND BOTTOM TO HAVE SOD OR ANCHORED SEEDING MATTING BEFORE PAVING CAN BEGIN.

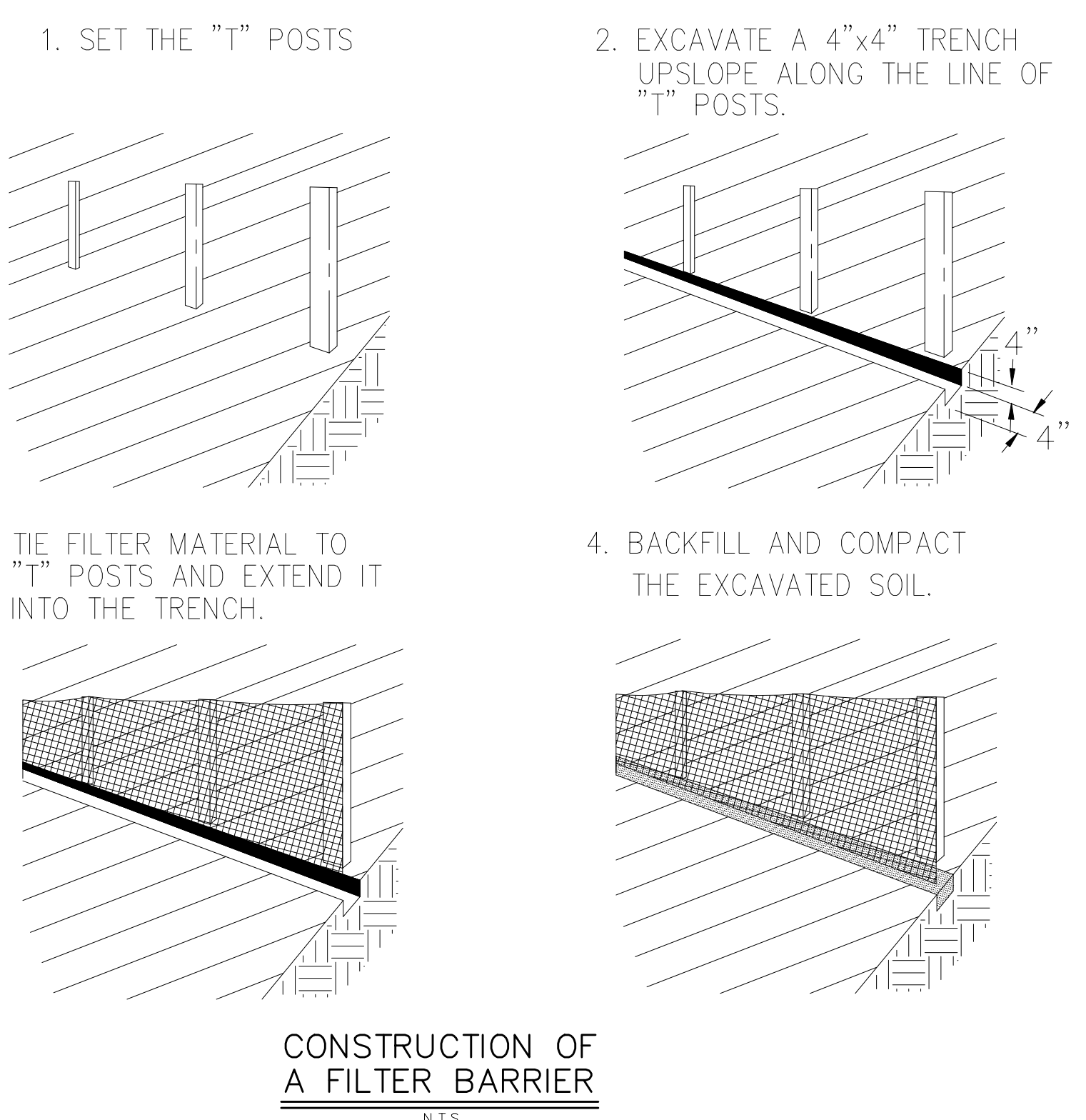

CONSTRUCTION OF A FILTER BARRIER
 N.T.S.

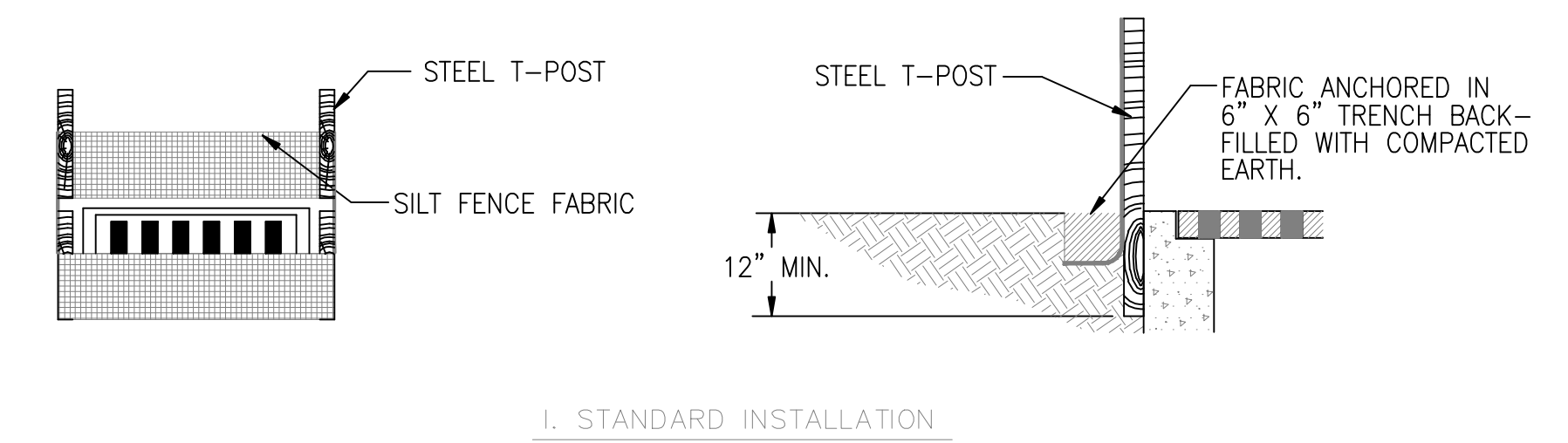

I. STANDARD INSTALLATION

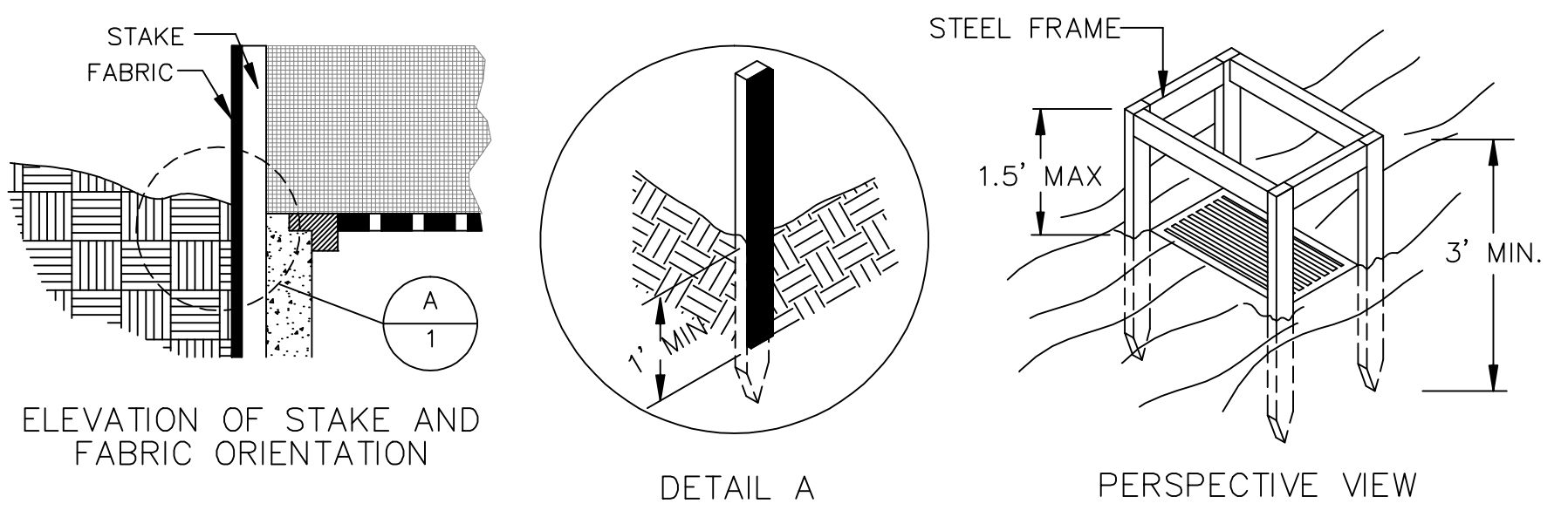

DETAIL A PERSPECTIVE VIEW

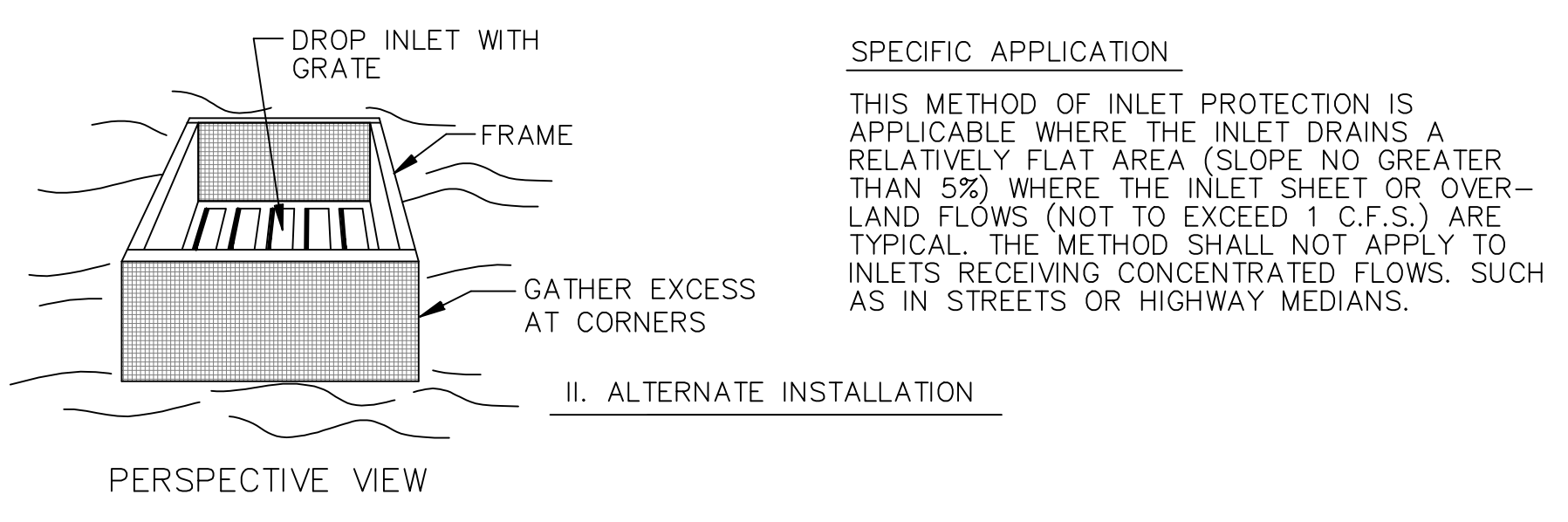

II. ALTERNATE INSTALLATION
 FILTER FABRIC PROTECTION
 N.T.S.

SPECIFIC APPLICATION
 THIS METHOD OF INLET PROTECTION IS APPLICABLE WHERE THE INLET DRAINS A RELATIVELY FLAT AREA (SLOPE NO GREATER THAN 5%) WHERE THE INLET SHEET OR OVERLAND FLOWS (NOT TO EXCEED 1 C.F.S.) ARE TYPICAL. THE METHOD SHALL NOT APPLY TO INLETS RECEIVING CONCENTRATED FLOWS, SUCH AS IN STREETS OR HIGHWAY MEDIANS.

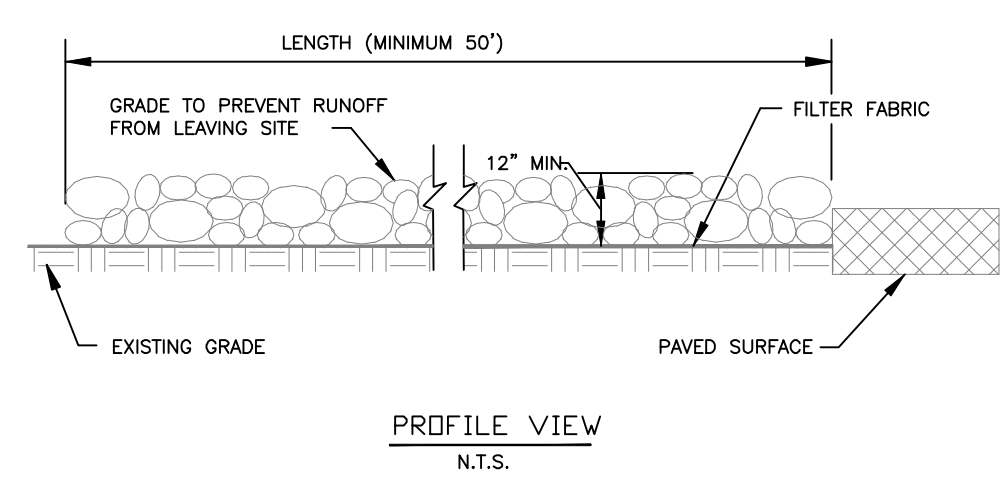

PROFILE VIEW
 N.T.S.

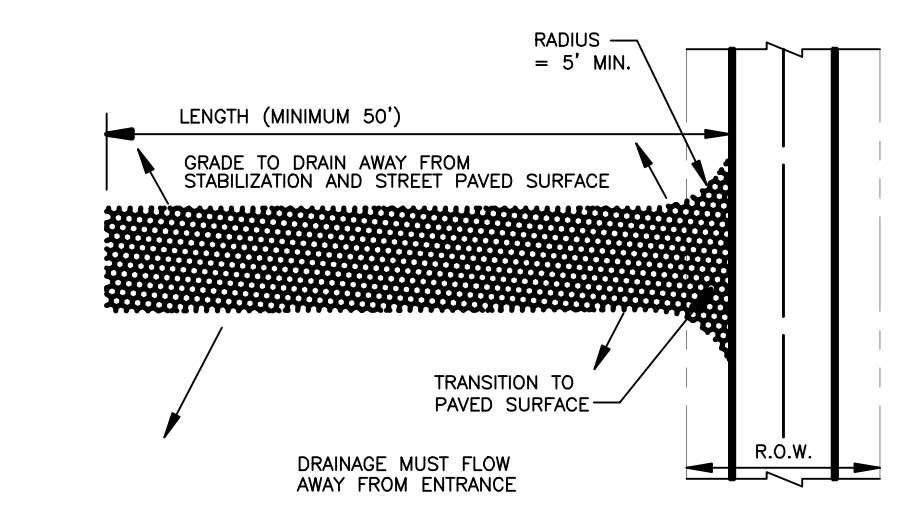

PLAN VIEW
 N.T.S.

STABILIZED CONSTRUCTION ENTRANCE GENERAL NOTES:

1. STONE SHALL BE 4 TO 6 INCH DIAMETER CRUSHED ROCK. NO CRUSHED CONCRETE ALLOWED.
2. LOCATION SHALL BE SHOWN ON PLANS, WITH A MINIMUM LENGTH OF 100 FEET FROM EDGE OF EXISTING PAVEMENT.
3. THE THICKNESS SHALL NOT BE LESS THAN 12 INCHES.
4. THE WIDTH SHALL BE NO LESS THAN THE FULL WIDTH OF ALL POINTS OF INGRESS OR EGRESS.
5. WHEN NECESSARY, VEHICLES SHALL BE CLEANED TO REMOVE SEDIMENT PRIOR TO ENTRANCE ONTO A PUBLIC ROADWAY. WHEN WASHING IS REQUIRED, IT SHALL BE DONE ON AN AREA STABILIZED WITH CRUSHED STONE WITH DRAINAGE FLOWING AWAY FROM BOTH THE STREET AND THE STABILIZED ENTRANCE. ALL SEDIMENT SHALL BE PREVENTED FROM ENTERING ANY STORM DRAIN, DITCH OR WATERCOURSE USING APPROVED METHODS.
6. THE ENTRANCE SHALL BE MAINTAINED IN A CONDITION WHICH WILL PREVENT TRACKING OR FLOWING OF SEDIMENT ONTO PAVED SURFACES. THIS MAY REQUIRE PERIODIC TOP DRESSING WITH ADDITIONAL STONE AS CONDITIONS DEMAND. ALL SEDIMENT SPILLED, DROPPED, WASHED, OR TRACKED ONTO PAVED SURFACES MUST BE REMOVED IMMEDIATELY.
7. THE ENTRANCE MUST BE PROPERLY GRADED OR INCORPORATE A DRAINAGE SWALE TO PREVENT RUNOFF FROM LEAVING THE CONSTRUCTION SITE.

REVISED TO CONFORM TO CONSTRUCTION RECORDS.
 SAH DATE: 12-1-16

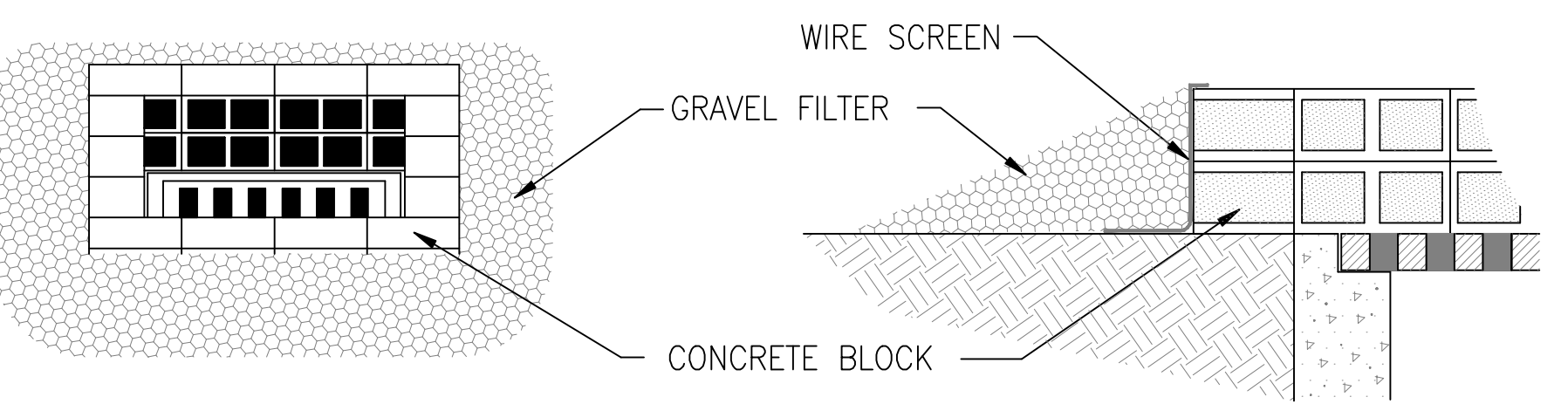

DROP INLET PROTECTION
 N.T.S.

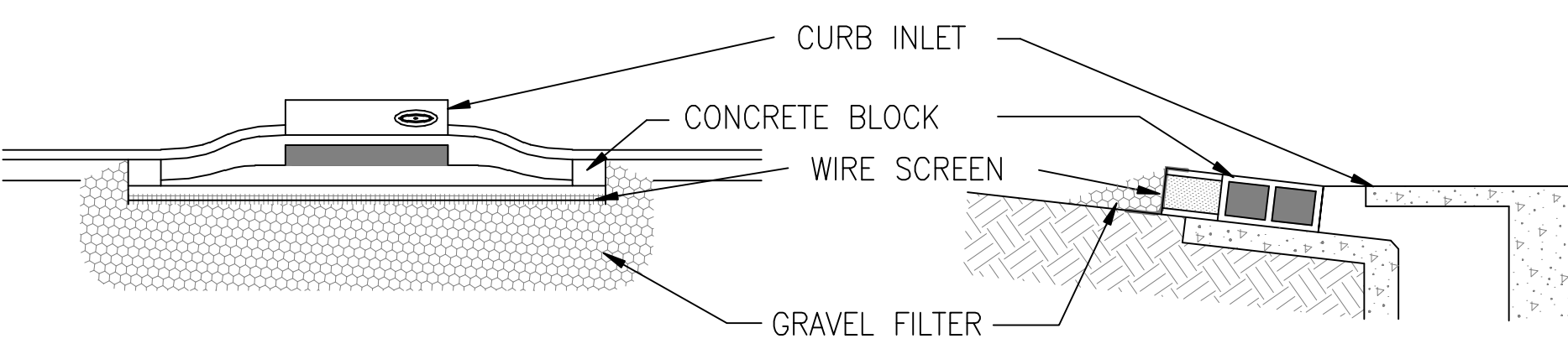

CURB INLET PROTECTION
 N.T.S.

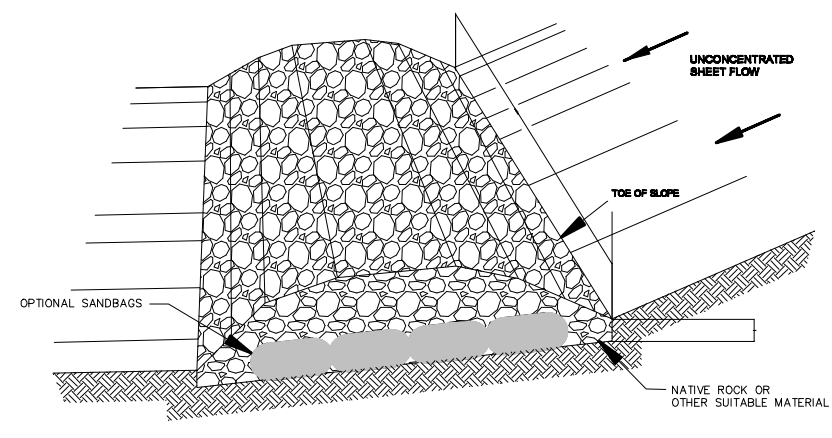

ROCK FILTER DAM AT TOE OF SLOPE
 N.T.S.