

DISCLAIMER: The use of this standard is governed by the "Texas Engineering Practice Act". No warranty of any kind is made by TxDOT for any purpose whatsoever. TxDOT assumes no responsibility for the conversion of this standard to other formats or for incorrect results or damages resulting from its use.

LEVELS DISPLAYED

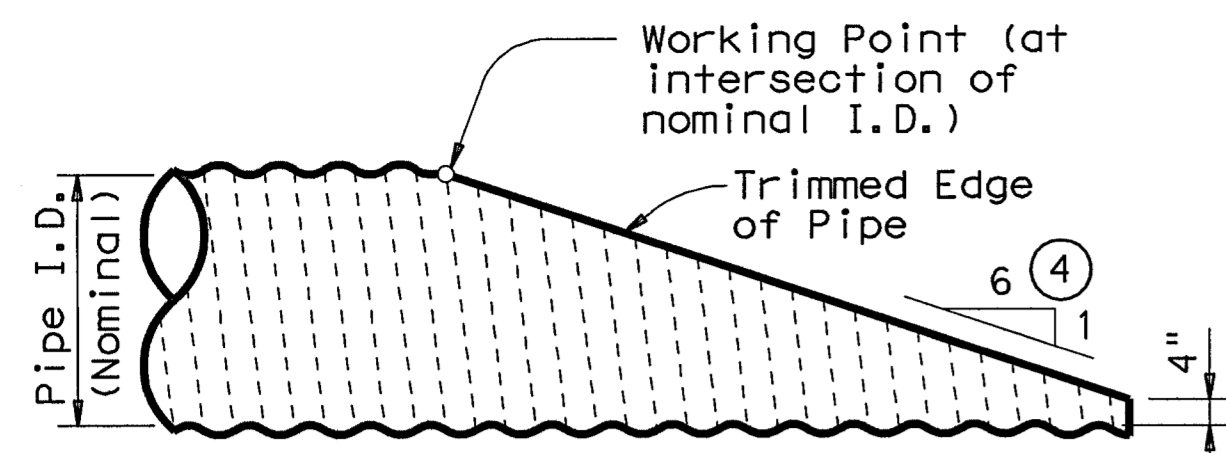

NOTE: All Cross Pipes, calculations, and dimensions are based on the pipe culverts mitered as shown in this detail. Alternate styles of mitered ends will require that appropriate adjustments be made to the values presented on this standard.

SIDE ELEVATION OF TYPICAL PIPE CULVERT MITER

(Showing Corrugated Metal Pipe Culvert.)
(Details at Concrete Pipe Culvert are similar.)

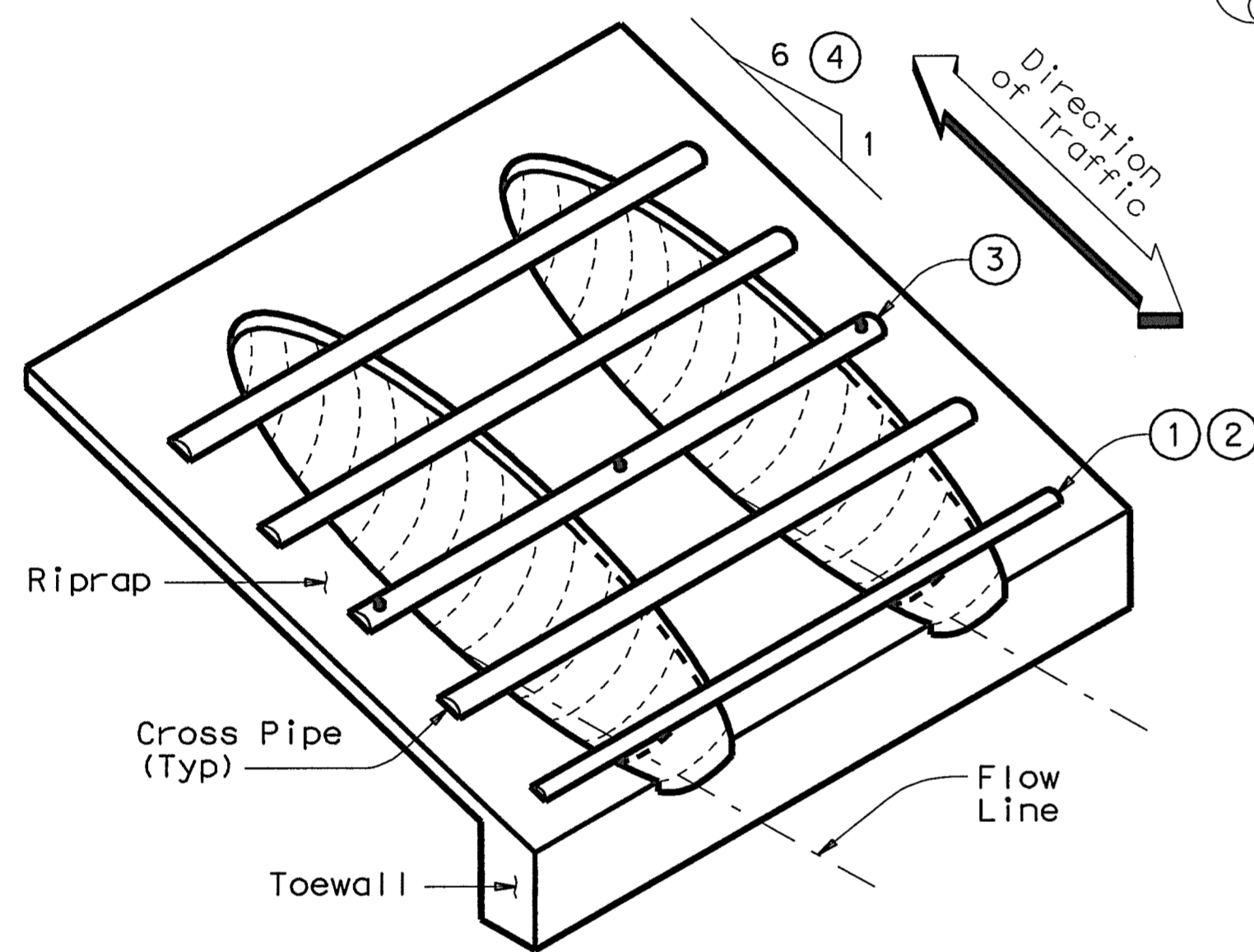

ISOMETRIC VIEW OF TYPICAL INSTALLATION

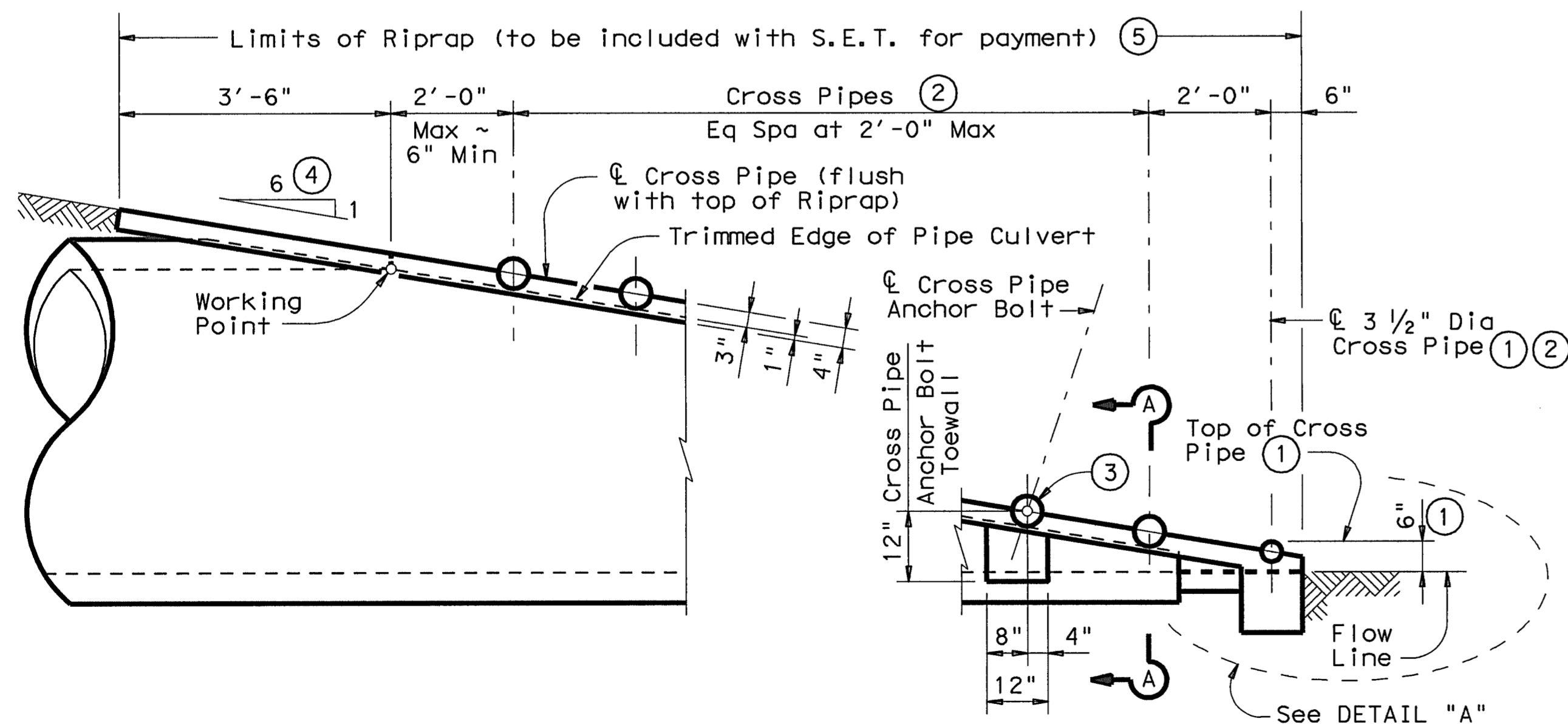

SIDE ELEVATION OF CAST-IN-PLACE CONCRETE

(Showing Concrete Pipe Culvert.)
(Details at Corrugated Metal Pipe Culvert are similar.)

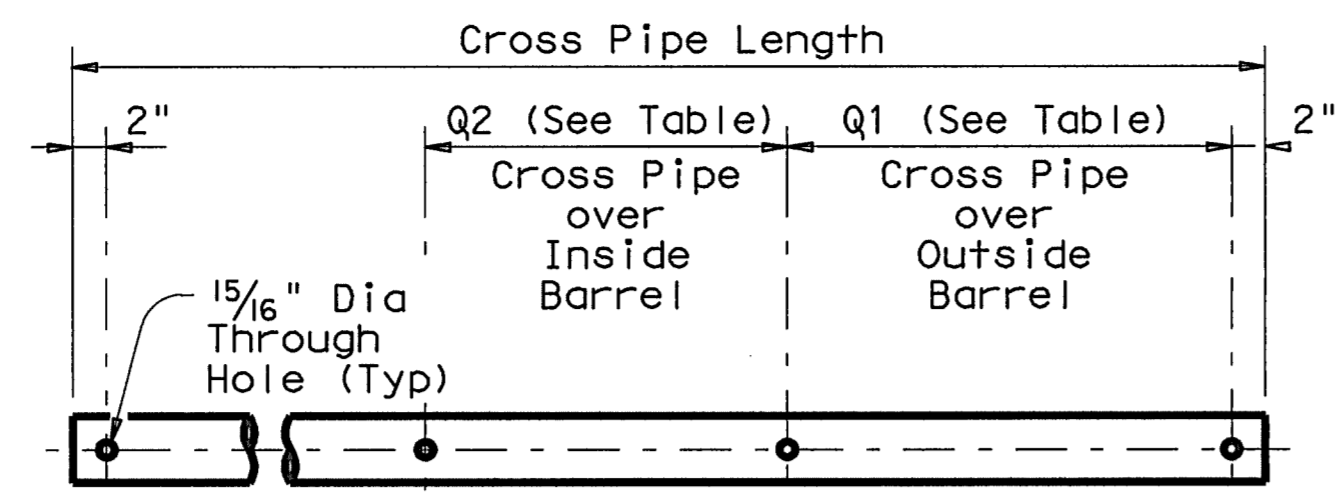

PIPE W/ BOLTED ANCHOR

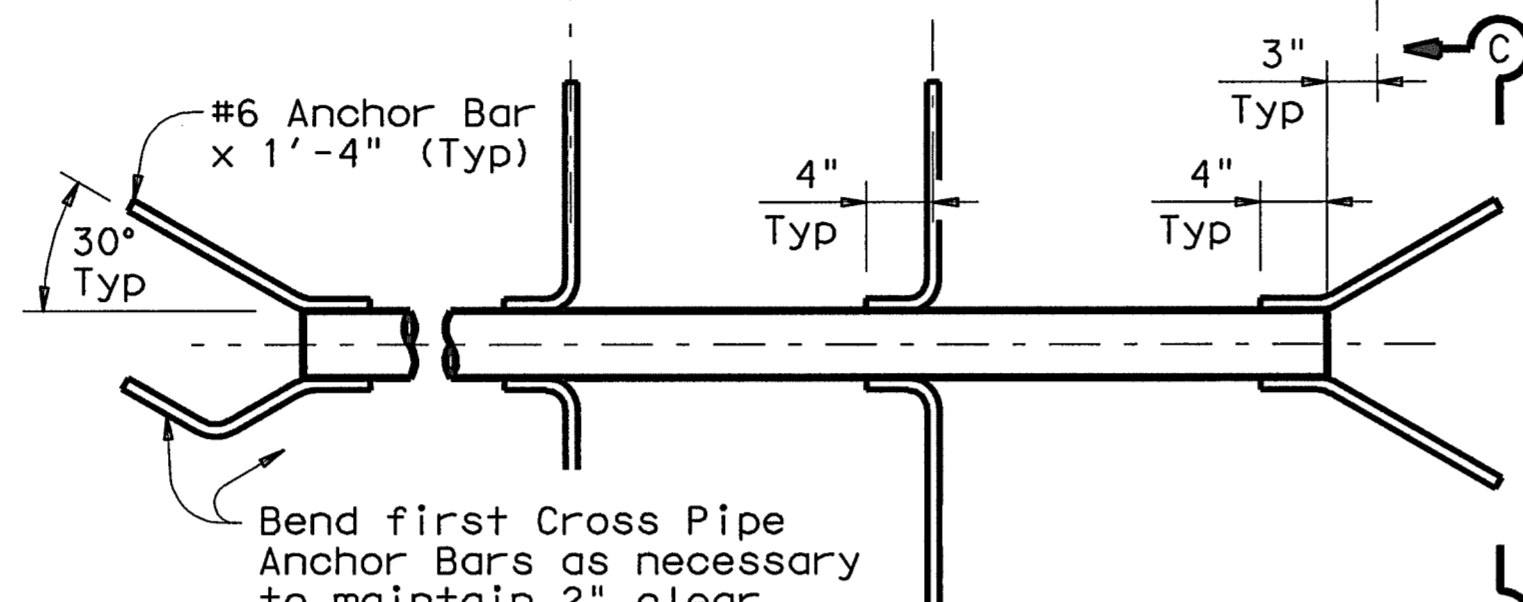

PIPE W/ ANCHOR BARS

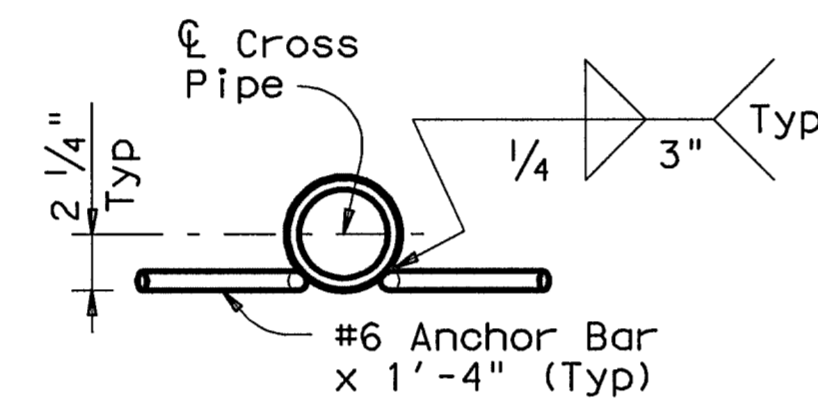

SECTION C-C

CROSS PIPE DETAILS

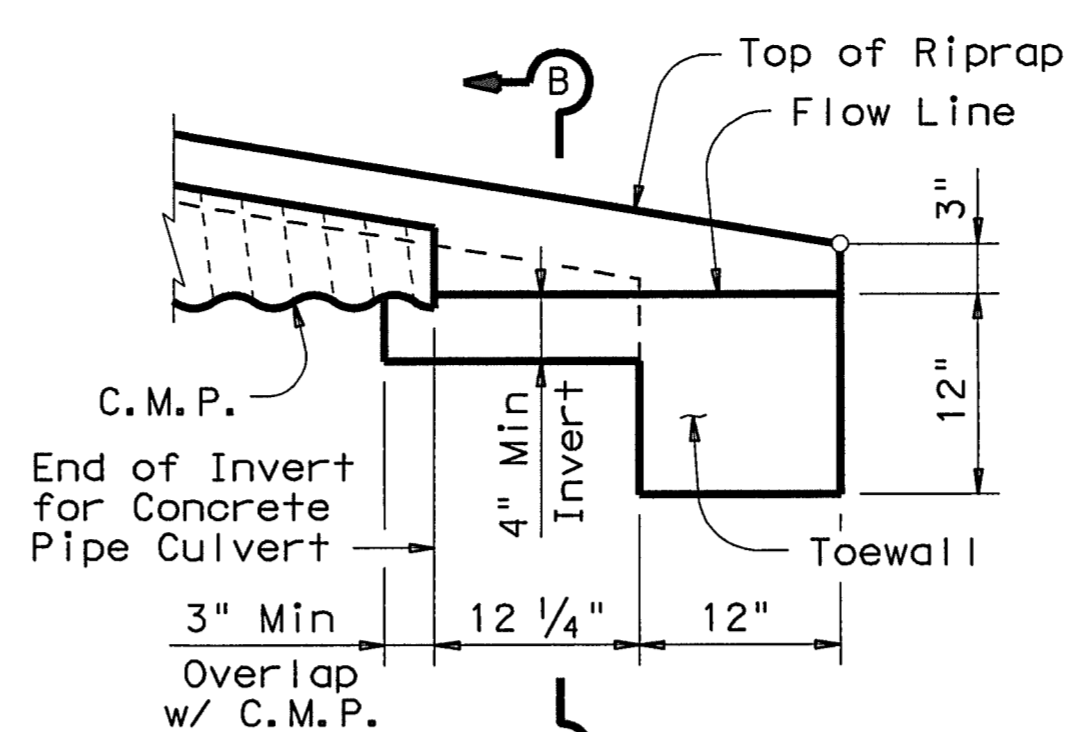

DETAIL "A"

(Showing Invert with Corrugated Metal Pipe Culvert. Concrete Pipe Culvert details are similar. Cross Pipes not shown for clarity.)

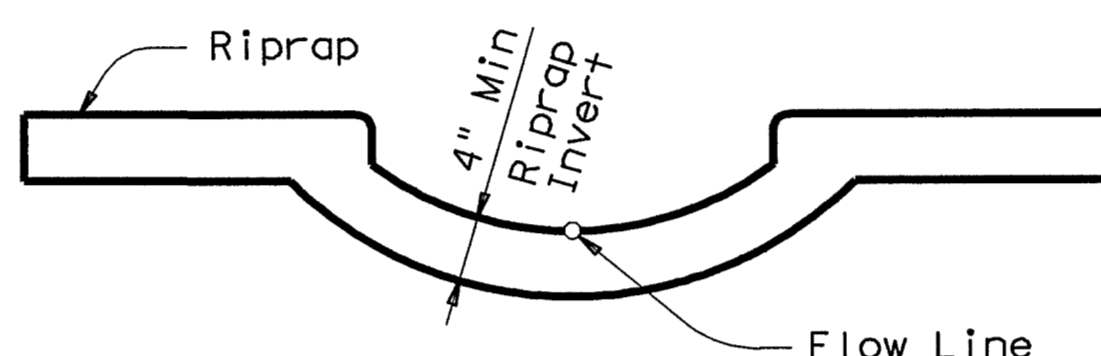

SECTION B-B

(Cross Pipes not shown for clarity.)

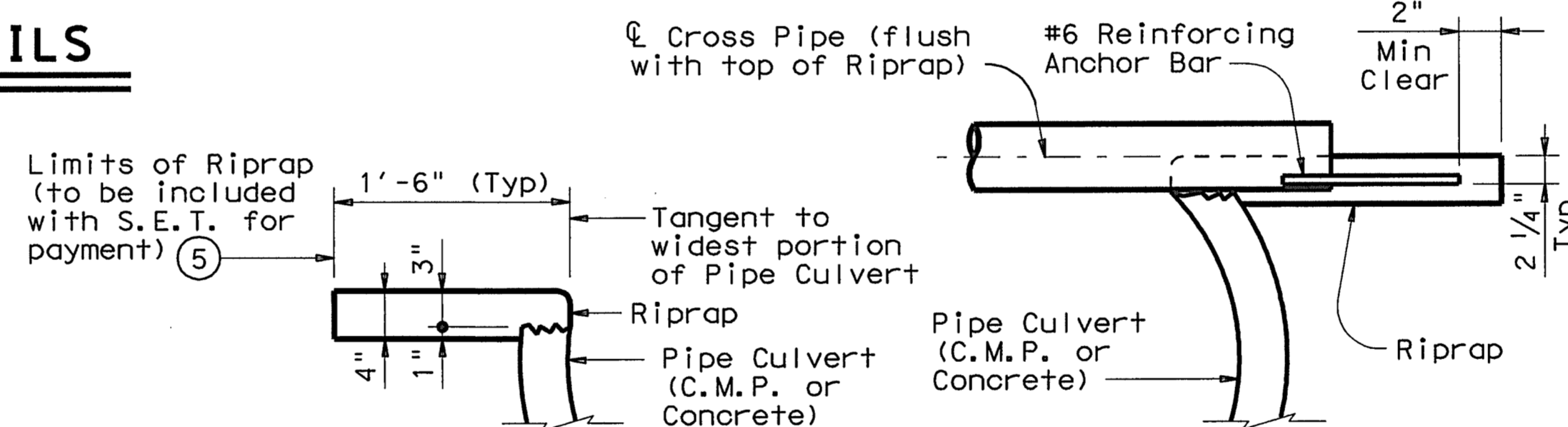

SHOWING TYPICAL PIPE CULVERT & RIPRAP

SHOWING CROSS PIPE WITH ANCHOR BAR

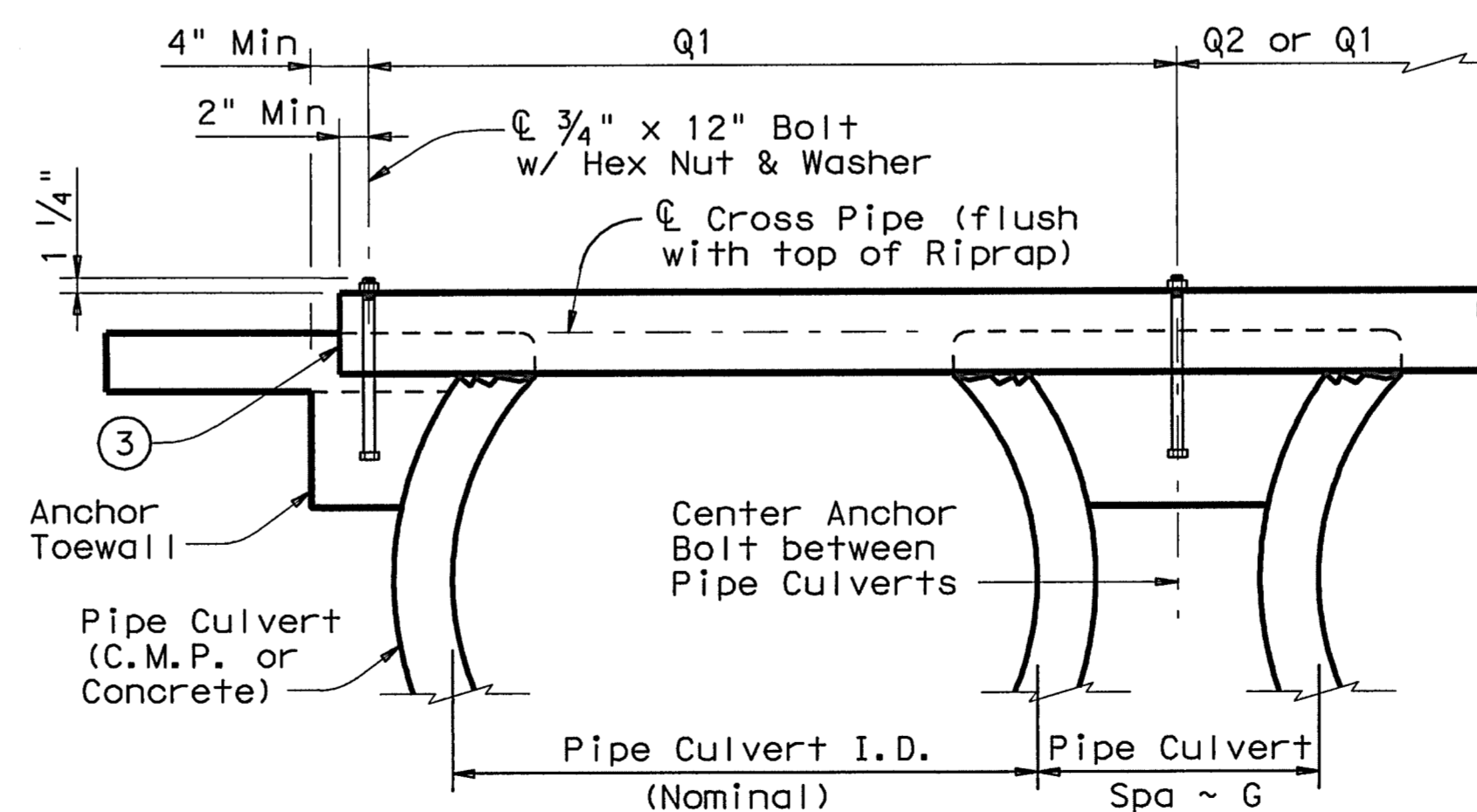

SHOWING CROSS PIPE WITH BOLTED ANCHOR

SECTION A-A

CROSS PIPE LENGTHS, REQUIRED PIPE SIZES, & RIPRAP QUANTITIES ②

Nominal Culvert I.D.	Conc Riprap (CY) ⑥	Pipe Culvert Spa ~ G	Single Barrel ~ Q1	Multi-Barrel ~ Q1	Q2	Conditions for use of Cross Pipes	Cross Pipe Size
12"	0.6	9"	N/A	2'-1"	1'-9"	3 or more Pipe Culverts	3" Std (3,500" O.D.)
15"	0.7	11"	N/A	2'-5"	2'-2"		
18"	0.8	1'-2"	N/A	2'-10"	2'-8"		
21"	0.9	1'-4"	N/A	3'-2"	3'-1"		
24"	0.9	1'-7"	N/A	3'-6"	3'-7"		
27"	1.0	1'-8"	N/A	3'-10"	3'-11"	3 or more Pipe Culverts	3 1/2" Std (4,000" O.D.)
30"	1.1	1'-10"	N/A	4'-2"	4'-4"	2 or more Pipe Culverts	
33"	1.2	1'-11"	4'-2"	4'-5"	4'-8"	All Pipe Culverts	
36"	1.3	2'-1"	4'-5"	4'-9"	5'-1"	All Pipe Culverts	4" Std (4,500" O.D.)
42"	1.5	2'-4"	4'-11"	5'-5"	5'-10"		
48"	1.7	2'-7"	5'-5"	6'-0"	6'-7"	All Pipe Culverts	5" Std (5,563" O.D.)
54"	2.0	3'-0"	5'-11"	6'-9"	7'-6"		
60"	2.2	3'-3"	6'-5"	7'-4"	8'-3"		
66"	2.4	3'-3"	6'-11"	7'-10"	8'-9"		
72"	2.7	3'-4"	7'-5"	8'-5"	9'-4"		

- The proper installation of the first Cross Pipe is critical for vehicle safety. The top of the first Cross Pipe must be placed at no more than 6" above the flow line.
- Size of Cross Pipes, except the first bottom pipe, shall be as shown in the PIPE SIZE table. The first bottom pipe shall be 3 1/2" Standard Pipe (4" O.D.).
- The third Cross Pipe from the bottom of the Culvert shall always be installed using a bolted connection. Care shall be taken to ensure that Riprap concrete does not flow into the Cross Pipe so as to permit disassembly of the bolted connection to allow cleanout access. At the Contractor's option, all other Cross Pipes may also be installed using the bolted connection details.
- Match Cross Slope as shown elsewhere in the plans. Cross Slope of 6:1 or flatter is required for vehicle safety.
- Riprap placed beyond the limits shown will be paid as Concrete Riprap in accordance with Item 432, "Riprap".
- Quantities shown are for one end of one reinforced Concrete Pipe Culvert. For multiple pipe culverts or for Corrugated Metal Pipe Culverts, quantities will need to be adjusted. Riprap quantities are for Contractor's information only.

GENERAL NOTES:

Cross Pipes are designed for a traversing load of 10,000 pounds at yield as recommended by Research Report 280-2F, "Safety Treatment of Roadside Parallel-Drainage Structures", Texas Transportation Institute, March 1981.

Safety End Treatments shown herein are intended for use in those installations where out of control vehicles are likely to traverse the openings approximately perpendicular to the Cross Pipes.

Riprap and all necessary inverts shall be Concrete Riprap conforming to the requirements of Item 432, "Riprap".

Payment for riprap and toewall is included in the Price Bid for each Safety End Treatment.

Cross Pipes shall conform to the requirements of ASTM A53 (Type E or S, Grade B), ASTM A500 (Grade B), or API 5LX52.

Bolts and nuts shall conform to ASTM A307. All steel components, except concrete reinforcing, shall be galvanized after fabrication. Galvanizing damaged during transport or construction shall be repaired in accordance with the specifications.

Texas Department of Transportation
Bridge Division

SAFETY END TREATMENT FOR 12" DIA TO 72" DIA PIPE CULVERTS TYPE II ~ PARALLEL DRAINAGE

SETP-PD

FILE: setppdse.dgn	DW: GAF	CK: CAT	DW: JRP	CK: GAF
© TxDOT May 2005	DISTRICT	FEDERAL AID PROJECT		SHEET
REVISIONS				
COUNTY		CONTROL	SECT	JOB
				HIGHWAY