

DISCLAIMER: The use of this standard is governed by the "Texas Engineering Practice Act". No warranty of any kind is made by TxDOT for any purpose whatsoever. TxDOT assumes no responsibility for the conversion of this standard to other formats or for incorrect results or damages resulting from its use.

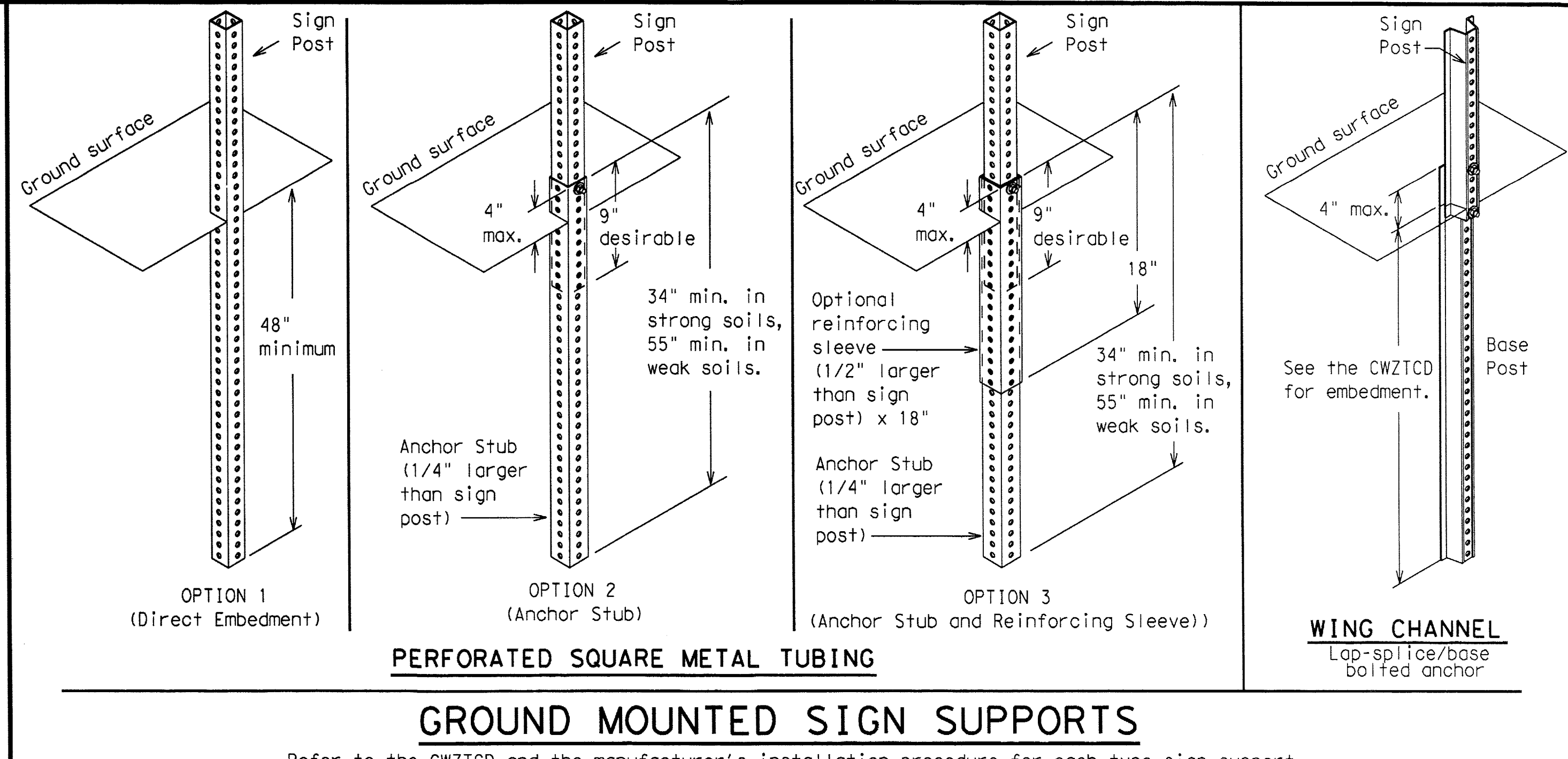

Refer to the CWZTCD and the manufacturer's installation procedure for each type sign support. The maximum sign square footage shall adhere to the manufacturer's recommendation. Two post installations can be used for larger signs.

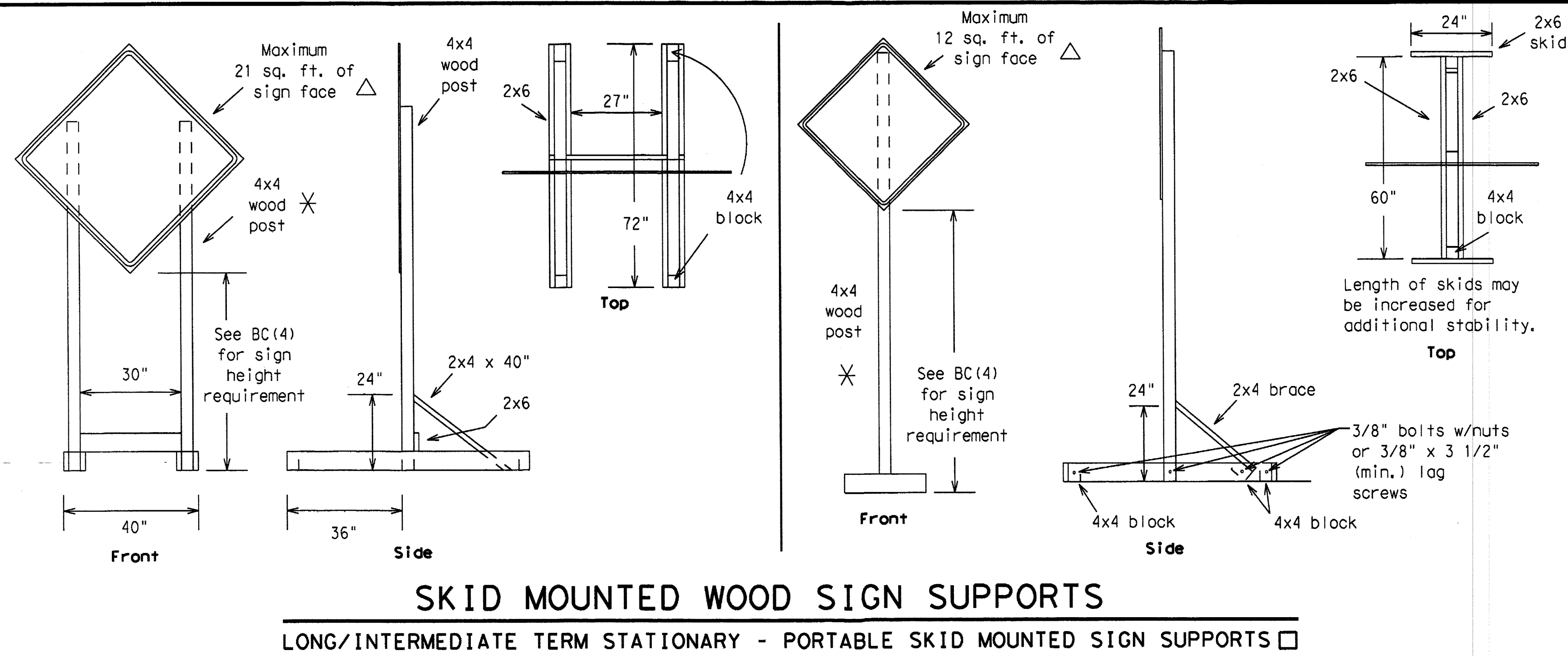
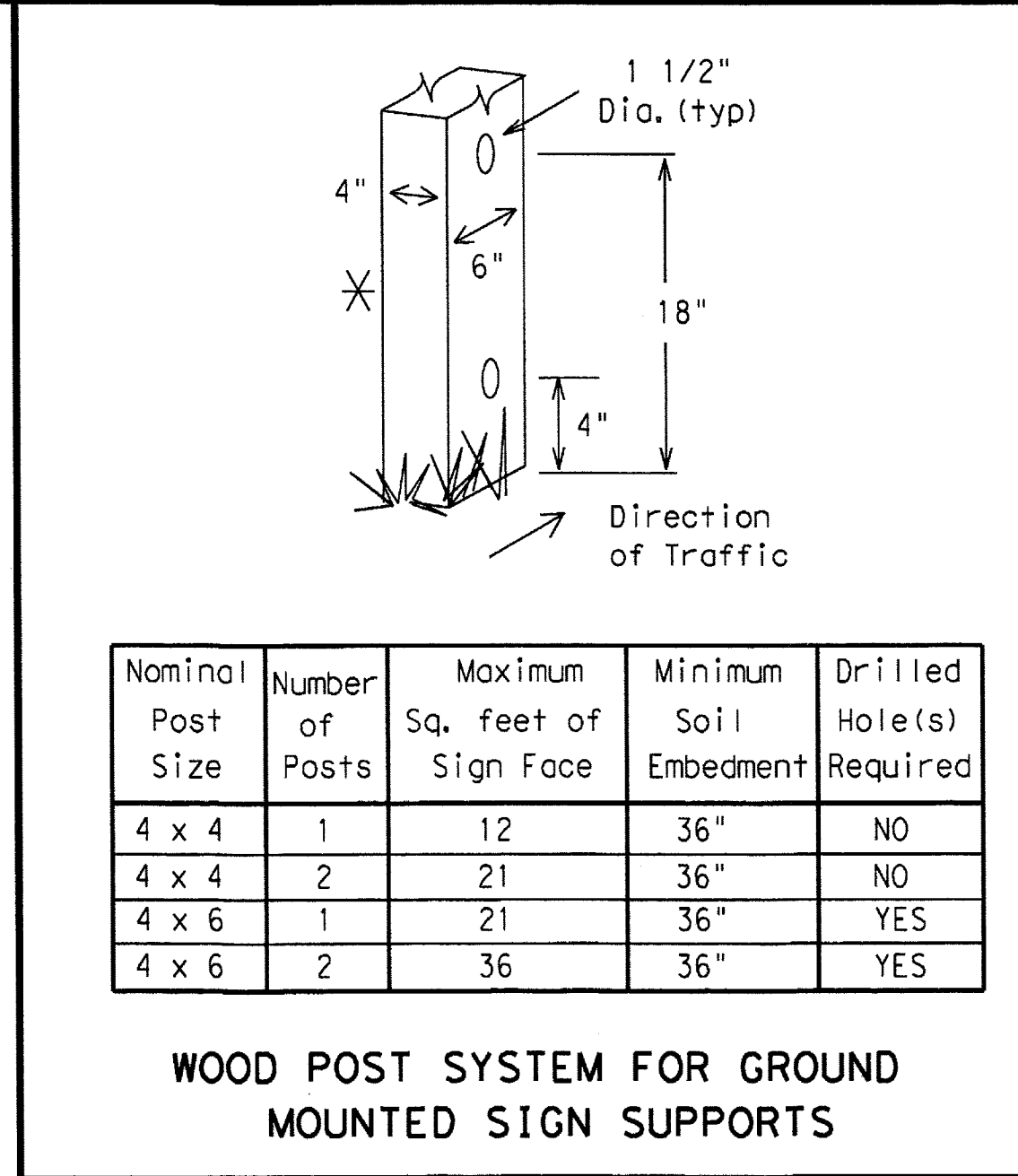
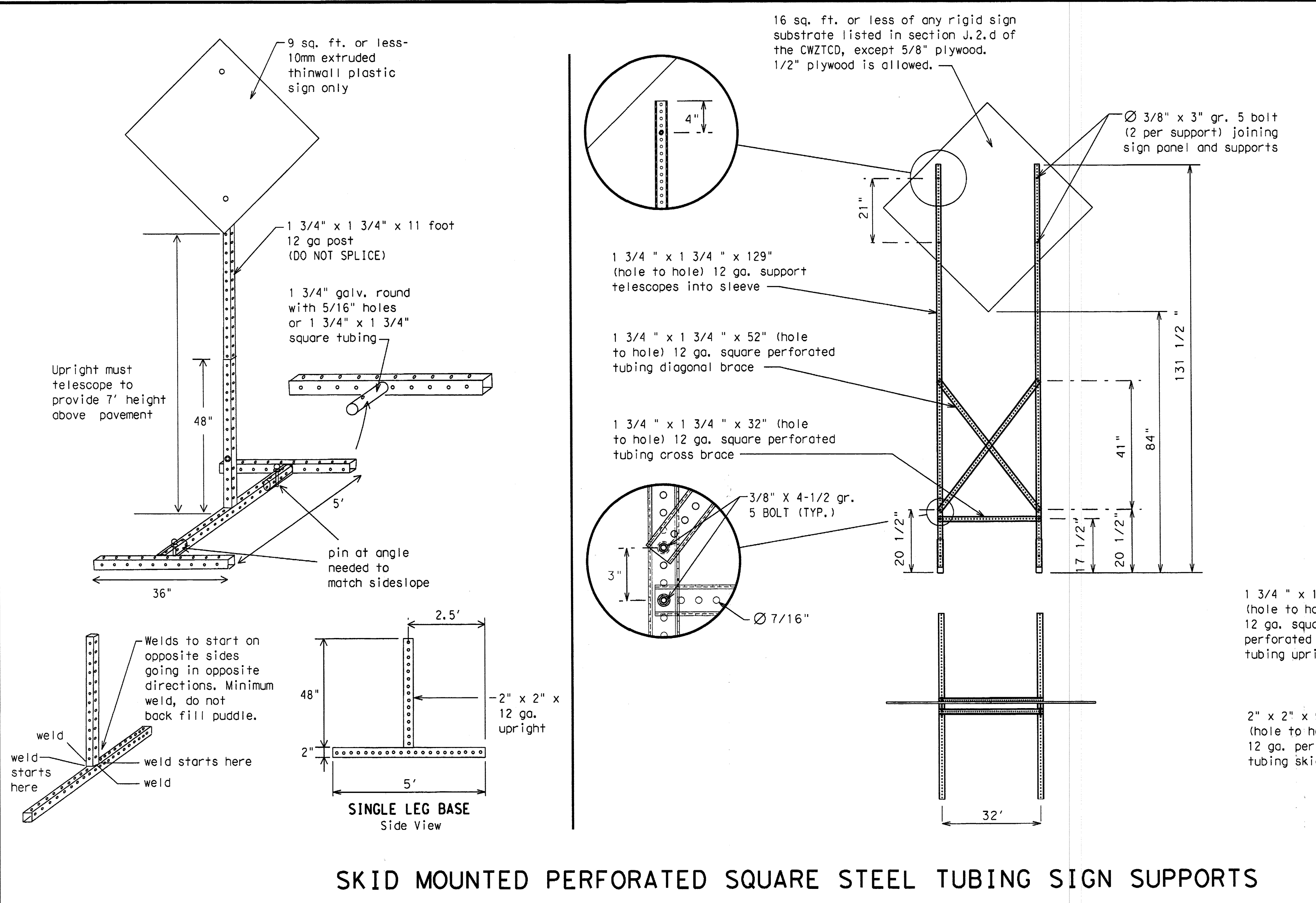

WEDGE ANCHORS
Both steel and plastic Wedge Anchor Systems as shown on the SMD Standard Sheets may be used as temporary sign supports for signs up to 10 square feet of sign face. They may be set in concrete or in sturdy soils if approved by the Engineer. (See web address for "Traffic Engineering Standard Sheets" on BC(1)).

OTHER DESIGNS
MORE DETAILS OF APPROVED LONG/INTERMEDIATE AND SHORT TERM SUPPORTS CAN BE FOUND ON THE CWZTCD LIST. SEE BC(1) FOR WEBSITE LOCATION.

- GENERAL NOTES**
- Nails may be used in the assembly of wooden sign supports, but 3/8" bolts with nuts or 3/8" x 3 1/2" lag screws must be used on every joint for final connection.
 - No more than 2 sign posts shall be placed within a 7 ft. circle, except for specific materials noted on the CWZTCD List.
 - When project is completed, all sign supports and foundations shall be removed from the project site. This will be considered subsidiary to item 502.

- See BC(4) for definition of "Work Duration."
- ✕ Wood sign posts MUST be one piece. Splicing will NOT be allowed. Posts shall be painted white.
- △ See the CWZTCD for the type of sign substrate that can be used for each approved sign support.

**BARRICADE AND CONSTRUCTION
TYPICAL SIGN SUPPORT**

BC (5) - 14

FILE: bc-14.dgn	DN: TxDOT	CK: TxDOT	DR: TxDOT	CR: TxDOT
© TxDOT November 2002	CON: SECT	JOB	HIGHWAY	
REVISONS				
9-07	8-14			
7-13				
	DIST	COUNTY		SHEET NO.
				R 20

DATE: FILE: