

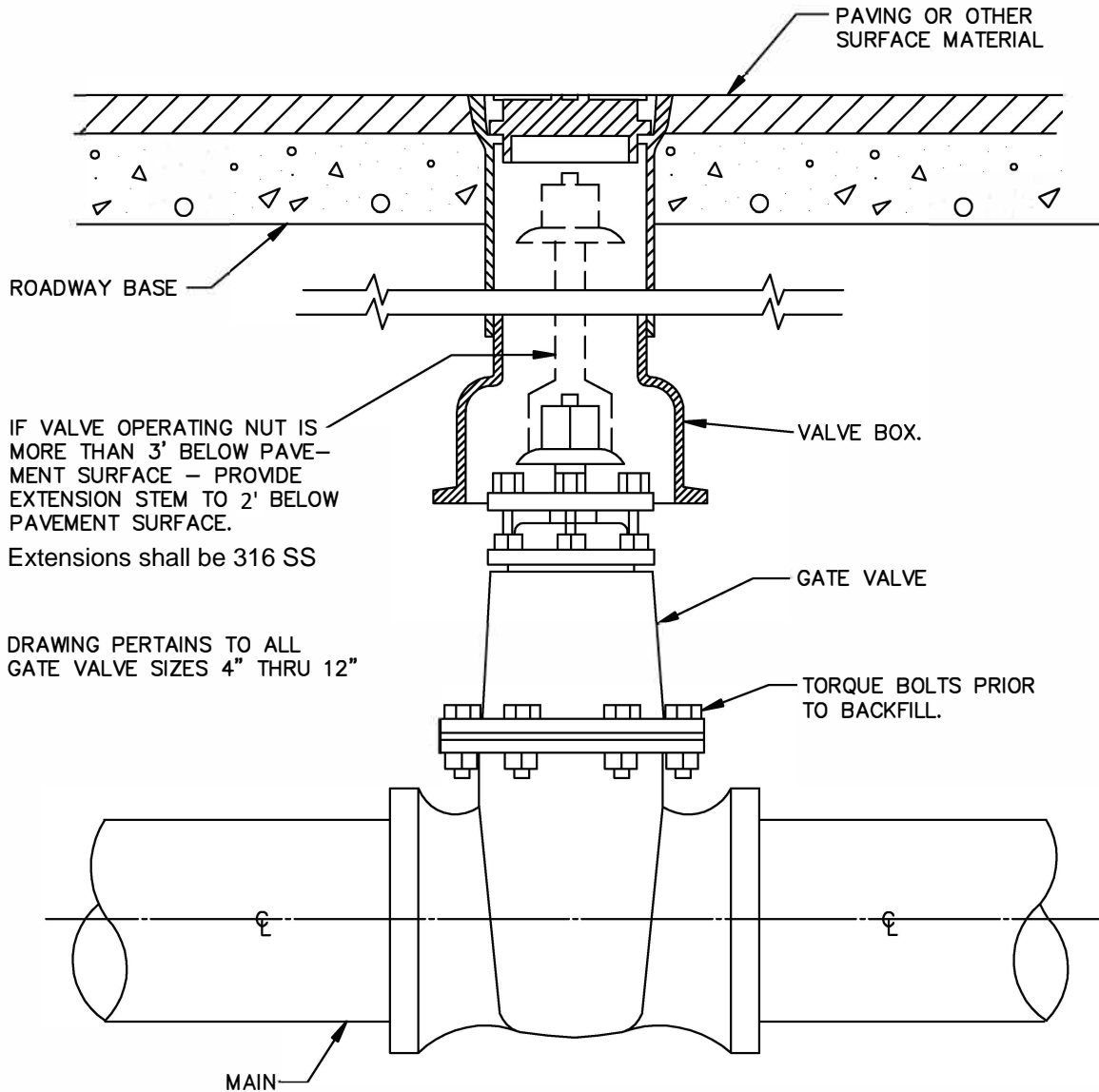

NOTE:

IN UNPAVED AREAS, INSTALL 2' x 2' x 6" CONCRETE VALVE PAD FLUSH WITH THE TOP OF VALVE BOX. REINFORCE WITH #3 BARS ON 6" CENTERS BOTH WAYS.



GATE VALVE BOX AND
EXTENSION STEM
N.T.S.

GATE VALVE 4" TO 12" BOX & EXTENSION STEM	CITY OF ROCKWALL 	STANDARD SPECIFICATION REFERENCE 502.6.6*	
		DATE AUG. '19	STANDARD DRAWING NO. R-4050

*Section II Standard Drawings as of October 2004. Reference number only has been updated for Fifth Edition Specifications. *Public Works Construction Standards North Central Texas, Fifth Edition.*

PAVEMENT REPLACEMENT AS REQUIRED, SEE PLAN & PROFILE DRAWINGS FOR VALVE LOCATIONS & PAVEMENT REPLACEMENT DETAILS FOR REPAIRS

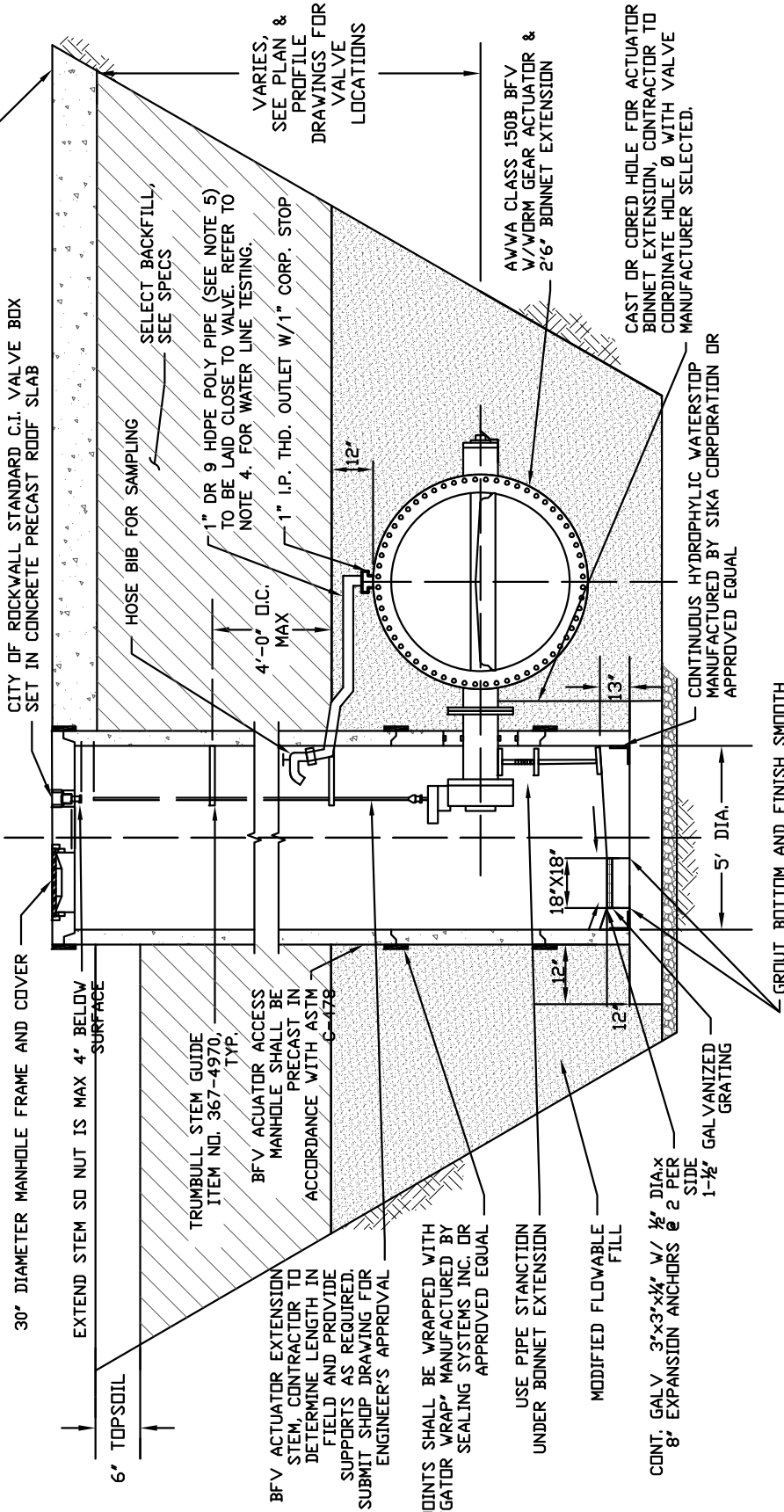

NOTES:

1. VALVE OPERATOR EXTENSION STEM SHALL BE 1" SOLID STEEL WITH WELDED CONNECTIONS. EXTENSION STEM SHALL NOT UTILIZE CLIPS AND SHALL NOT BE PERMANENTLY CONNECTED TO ACTUATOR.
2. WAX TAPE ALL BURIED FLANGES, BOLTS, AND MECHANICAL JOINTS.
3. WRAP VALVE IN 8 MIL POLYETHYLENE SHEET FOR BOND BREAKER PRIOR TO PLACEMENT OF MODIFIED FLOWABLE FILL.
4. DURING THE WATER LINE TESTING PROCESS, THE 1" HDPE DR9 POLY PIPE SHALL BE EXTENDED AND SUPPORTED TO 3 FEET ABOVE THE RIM ELEVATION OF THE VAULT FOR USE AS A WATER SAMPLING TEST STATION.
5. POLY PIPE SHALL BE SEAMLESS 250 PSI BLUE COLORED POLYETHYLENE ASTM D2737, DR 9, CTS WATER PIPE.
6. CONTRACTOR SHALL VERIFY VALVE BONNET, ACTUATOR, AND STEM EXTENSION DIMENSIONS WITH VALVE MANUFACTURER. COORDINATE LOCATION OF THE 2-INCH SQUARE NUT WITH VALVE BOX CAST IN MANHOLE ROOF SLAB. SUBMIT SHOP DRAWINGS CLEARLY SHOWING DIMENSIONS AND LOCATION OF THE ALL SLAB OPENINGS. ENSURE ADEQUATE CLEARANCE FOR ACTUATOR AND HATCH OPENING.
7. FOR SIZES ABOVE 20-INCH, THE ENGINEER OF RECORD SHALL SUBMIT A STRUCTURAL DESIGN TO THE CITY FOR REVIEW AND APPROVAL FOR CONSTRUCTION. THE STRUCTURAL DESIGN AND DETAIL SHALL FOLLOW THE GENERAL CONFIGURATION AND LAYOUT ILLUSTRATED IN STD. DWG. NO. R-4060

SHEET 1 OF 3

16" THRU 21"

HORIZONTAL BUTTERFLY VALVES

CITY OF ROCKWALL



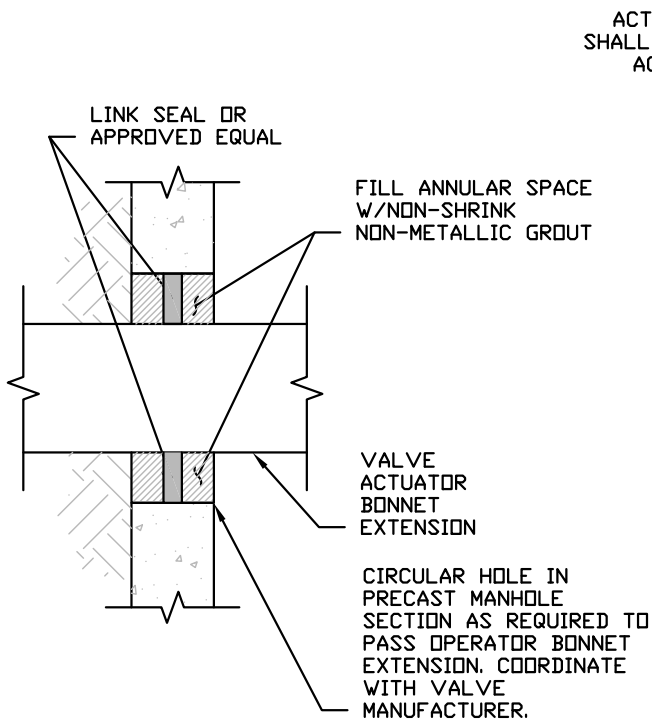
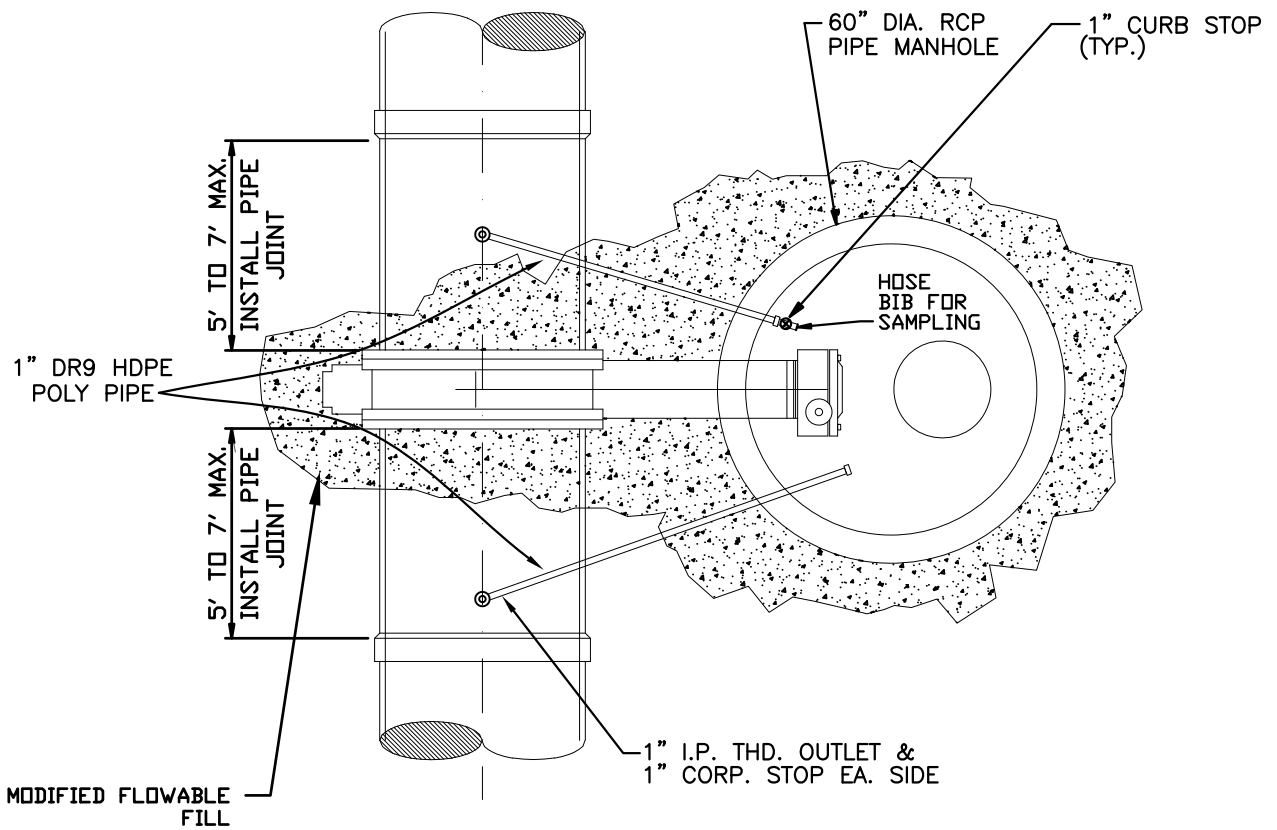

DATE
AUG '19

DRAWING NO.
R-4060

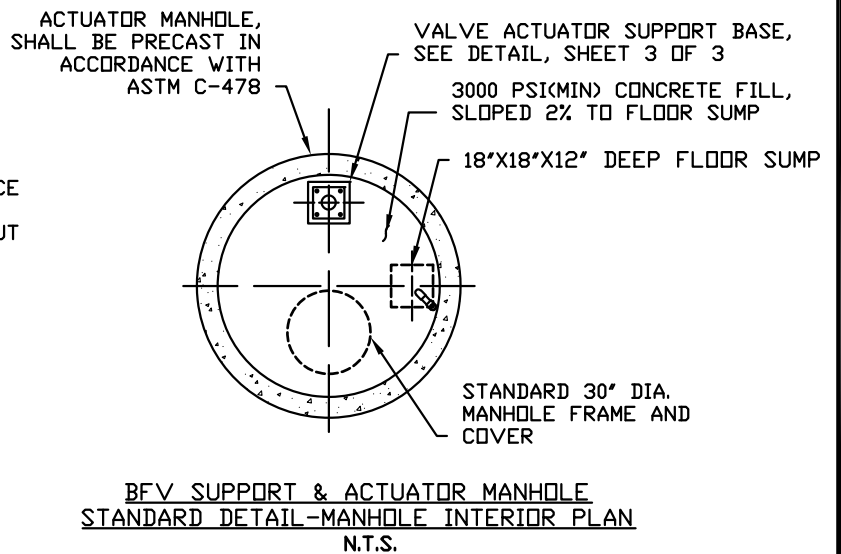

MANHOLE WALL PENETRATION DETAIL
N.T.S.



16" THRU 21"	CITY OF ROCKWALL		
HORIZONTAL BUTTERFLY VALVES		DATE AUG '19	DRAWING NO. R-4060

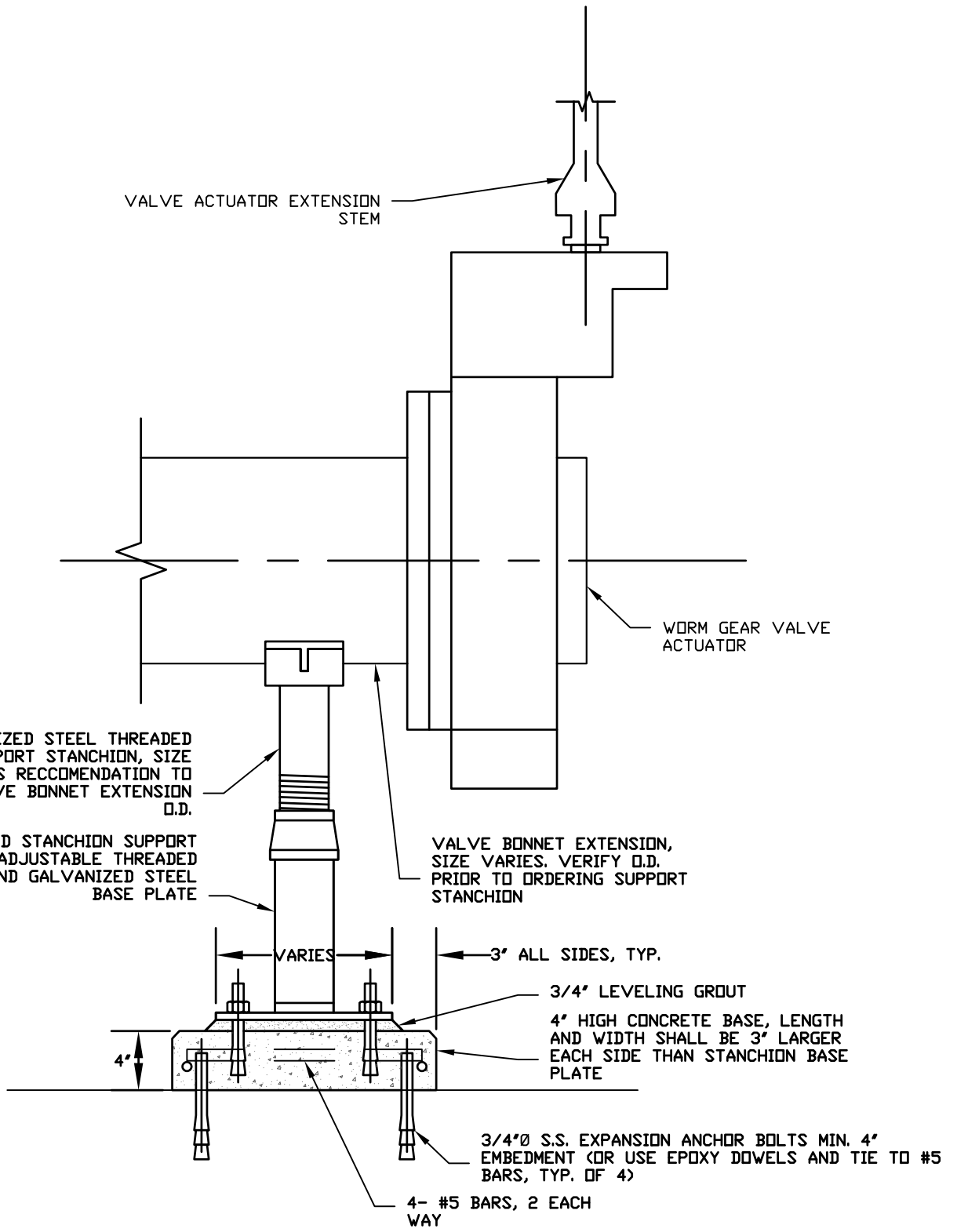

BFV SUPPORT & ACTUATOR MANHOLE STANDARD DETAIL- VALVE ACTUATOR SUPPORT
 N.T.S.

16" THRU 21"	CITY OF ROCKWALL		
HORIZONTAL BUTTERFLY VALVES		DATE AUG '19	DRAWING NO. R-4060

AIR VALVE	2"	BRASS WHEEL VALVE	2"	VENT PIPE	2"
-----------	----	-------------------	----	-----------	----

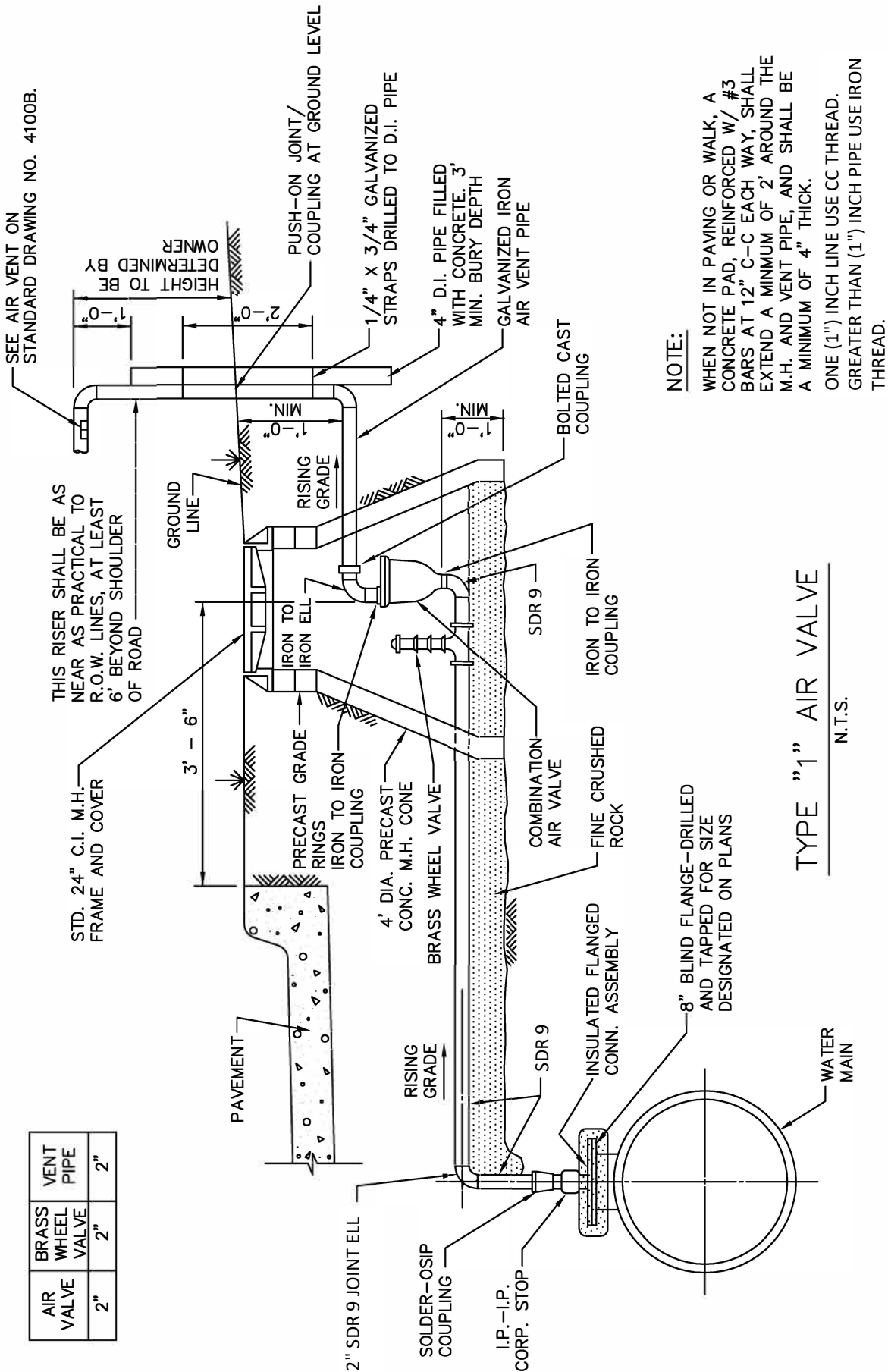

NOTE:
 WHEN NOT IN PAVING OR WALK, A CONCRETE PAD, REINFORCED W/ #3 BARS AT 12" C-C EACH WAY, SHALL EXTEND A MINIMUM OF 2' AROUND THE M.H. AND VENT PIPE, AND SHALL BE A MINIMUM OF 4" THICK.
 ONE (1") INCH LINE USE CC THREAD.
 GREATER THAN (1") INCH PIPE USE IRON THREAD.

TYPE "1" AIR VALVE

N.T.S.

STANDARD DRAWING NO.	R-4090
DATE	Mar. 2018
STANDARD SPECIFICATION REFERENCE	502.6.6*

CITY OF ROCKWALL



COMBINATION AIR VACUUM VALVE

TYPE "1"

STANDARD DRAWING NO.	R-4090
----------------------	--------

*Section II Standard Drawings as of October 2004. Reference number only has been updated for Fifth Edition Specifications. *Public Works Construction Standards North Central Texas, Fifth Edition.*

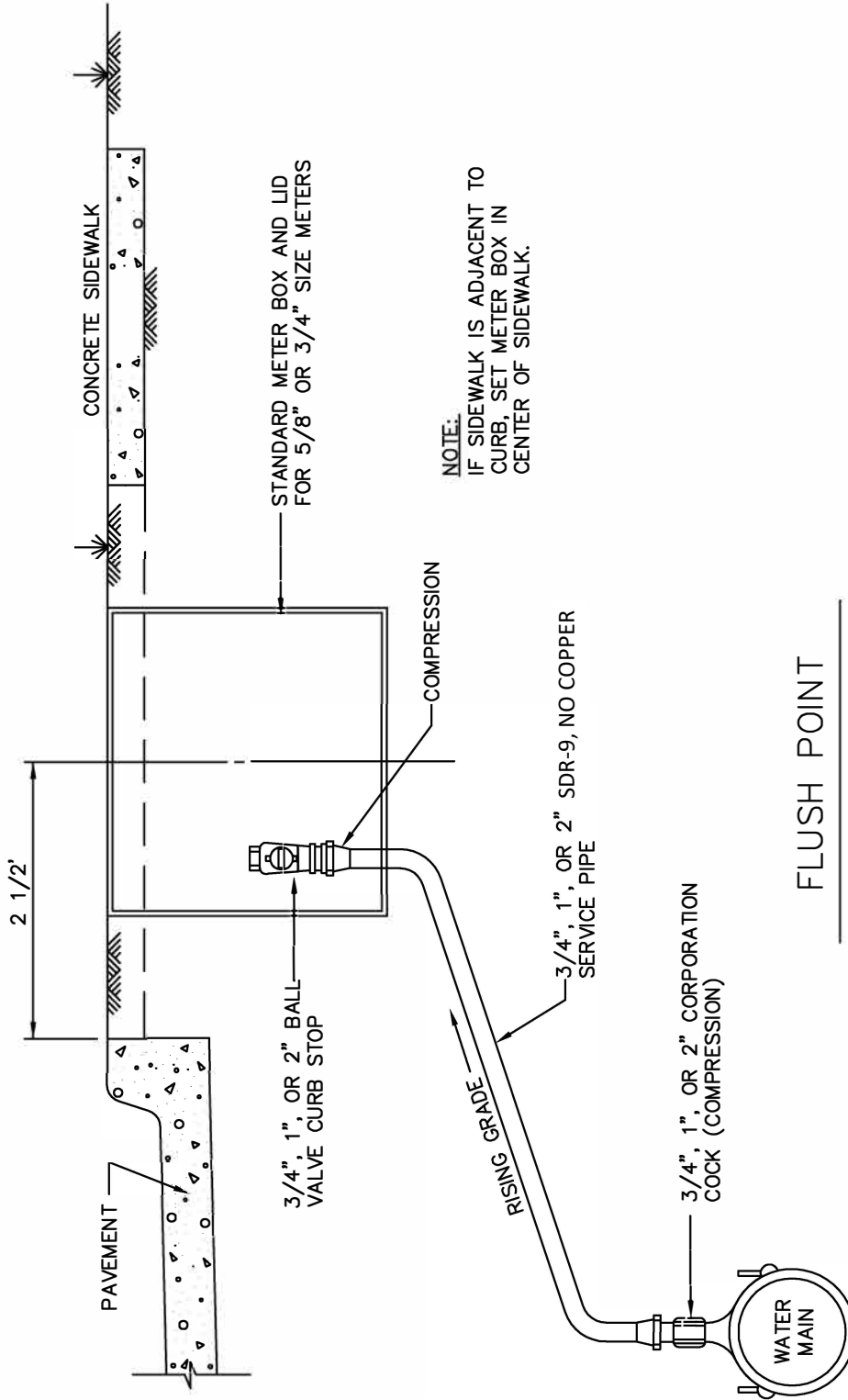

NOTE:
IF SIDEWALK IS ADJACENT TO CURB, SET METER BOX IN CENTER OF SIDEWALK.

FLUSH POINT

(SIZE DESIGNATED ON PLANS)
N.T.S.

FLUSH POINT INSTALLATION

TYPE "1"

CITY OF ROCKWALL



STANDARD SPECIFICATION REFERENCE
502.10.3*

DATE
Mar. 2018

STANDARD DRAWING NO.
R-4110

STANDARD DRAWING NO.
R-4110

*Section II Standard Drawings as of October 2004. Reference number only has been updated for Fifth Edition Specifications. *Public Works Construction Standards North Central Texas, Fifth Edition.*

NOTES:

1. IN GENERAL, ALL FIRE HYDRANTS SHALL CONFORM TO AWWA STANDARD SPECIFICATIONS FOR FIRE HYDRANTS FOR ORDINARY WATER WORKS SERVICE, C-502. FIRE HYDRANTS SHALL HAVE A 5 1/4" MIN. VALVE OPENING AND A BARREL APPROXIMATELY 7" INSIDE DIAMETER. ALL HYDRANTS SHALL BE EQUIPPED WITH A BREAKAWAY FLANGE.
2. ALL JOINTS TO BE RESTRAINED JOINTS. MEGA-LUG OR APPROVED EQUAL.
3. TYPICAL VALVE: ACTUAL VALVE LOCATION WILL DEPEND ON LOCATION OF WATER MAIN.
4. F.H. NO CLOSER THAN 18" TO EXISTING OR PROPOSED SIDEWALKS. (USUAL)
5. STANDARD BURY DEPTH 4' FEET
6. SET FIRE HYDRANT ON THE LOT LINE EXTENDED WHEN POSSIBLE.
7. F.H. SHALL BE LOCATED MINIMUM 1 FT. OUTSIDE OF THE AREA BETWEEN THE P.C.'S OF THE CORNER TURNING RADII AT INTERSECTIONS. (SEE PLAN VIEW)
8. PLACEMENT OF F.H. SHALL BE WHERE PUMPER NOZZLE IS PERPENDICULAR TO AND FACING THE NEAREST CURB.

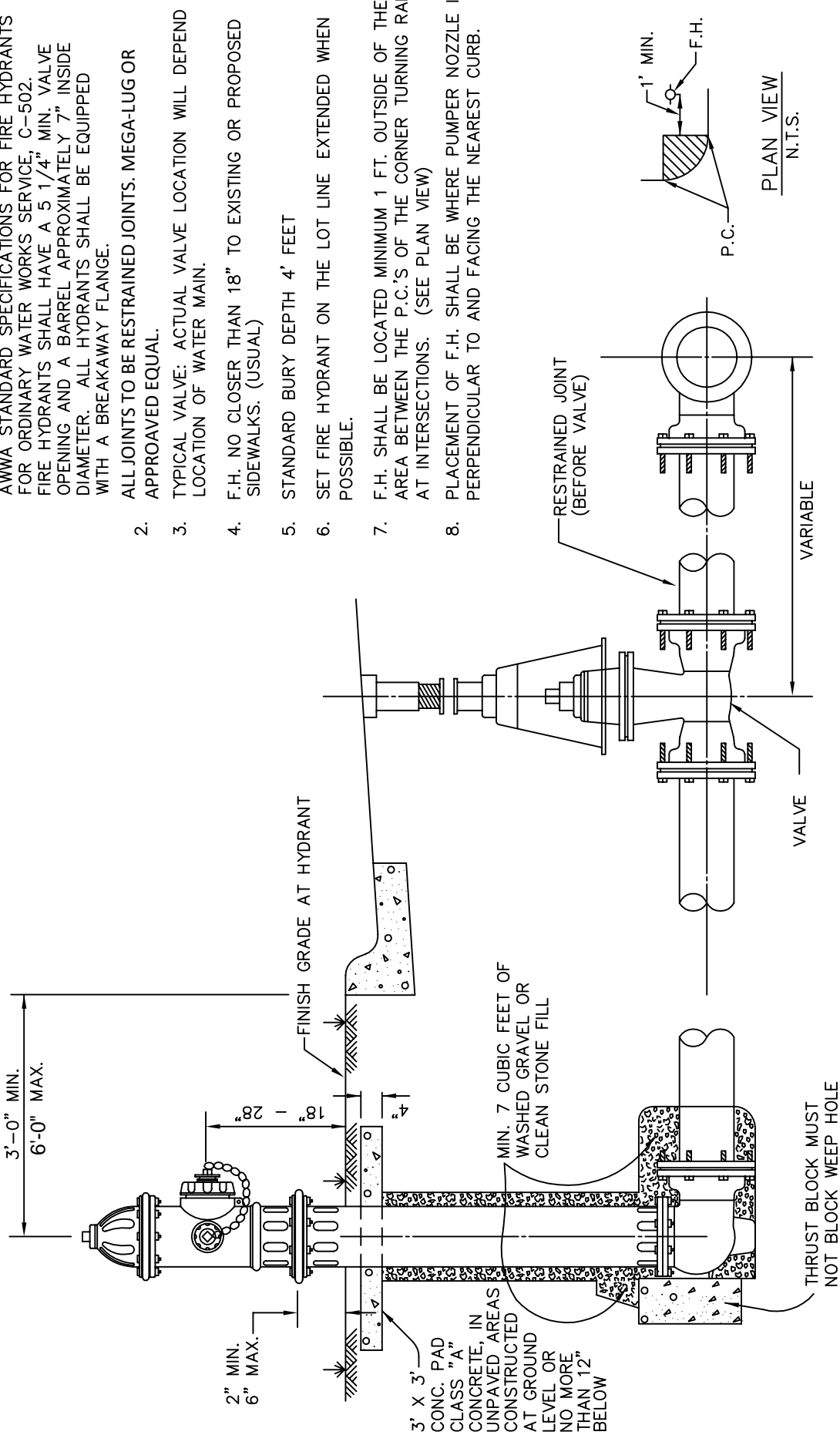

**FIRE HYDRANT
INSTALLATION**

CITY OF ROCKWALL



STANDARD SPECIFICATION REFERENCE
502.3

DATE
Aug. 2019

STANDARD DRAWING NO.
R-4120

STANDARD DRAWING NO.
R-4120

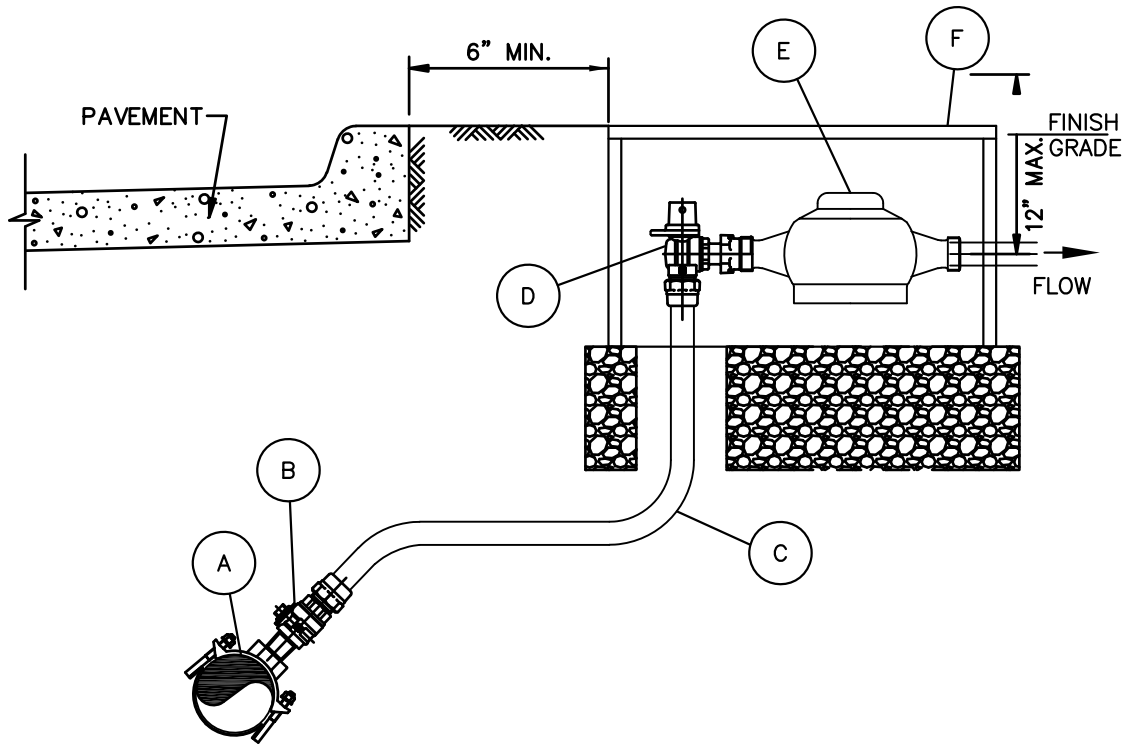

NOTES:

1. SERVICE PIPE SHALL BE 1" OR 2" SEAMLESS 250 PSI BLUE COLORED POLYETHYLENE ASTM D2737, SDR 9, CTS WATER SERVICE PIPE, NSF61 APPROVED.
2. TOP OF METER BOXES SHALL BE 1" ABOVE FINISHED GRADE.
3. METER BOX SHALL HAVE A MINIMUM OF 6" OF GRAVEL BENEATH METER BOX AS ILLUSTRATED.
4. LOCATION OF THE METER BOX SHALL BE LOCATED TO ALLOW 6" CLEARANCE FROM CURB.

MATERIAL LIST:

- A. SERVICE SADDLE SHALL BE BRASS WITH DOUBLE BRONZE FLATTENED STRAPS OR STAINLESS STEEL DOUBLE BOLT WIDE STRAPS. NO BANDED OR HINGED STRAPS SHALL BE ALLOWED. SERVICE SADDLES SHALL MEET AWWA/CC TAPPING OUTLET (TAPERED THREADS) REQUIREMENTS. ALL SERVICE SADDLES SHALL BE PER APPROVED WATER MATERIALS LIST.
- B. 1" OR 2" CORPORATION STOP PER APPROVED WATER MATERIALS LIST.
- C. 1" OR 2" SERVICE PIPE SHALL BE SEAMLESS 250 PSI BLUE COLORED POLYETHYLENE ASTM D2737, SDR9, CTS WATER SERVICE PIPE, NSF61 APPROVED.
- D. 1" OR 2" LOCKING ANGLE METER VALVE (STOP) PER APPROVED WATER MATERIALS LIST.
- E. WATER METERS CENTERED IN BOX AS ILLUSTRATED.
- F. ROUND METER BOX PER APPROVED WATER MATERIALS LIST.

WATER SERVICE INSTALLATION

CITY OF ROCKWALL

1" OR 2" LINE



DATE
AUG '19

DRAWING NO.
R-4130

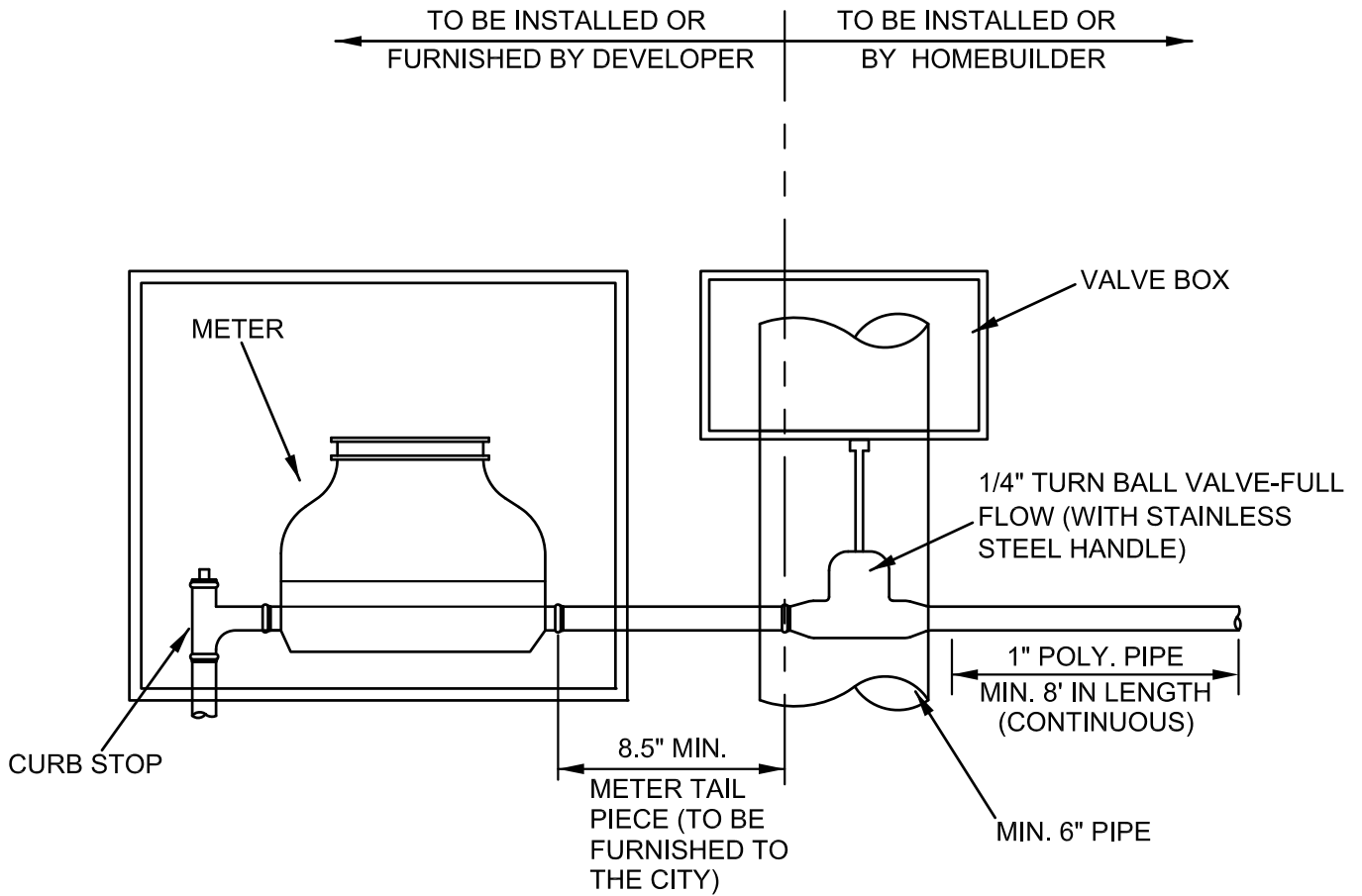

NOTE:

VALVE BOX TO BE TRAFFIC RATED IF UNDER PAVING.

SINGLE SERVICE METER TAIL CONNECTION
NOT TO SCALE

WATER METER DETAIL	CITY OF ROCKWALL		
SINGLE SERVICE		DATE AUG. '15	DRAWING NO. R-4145

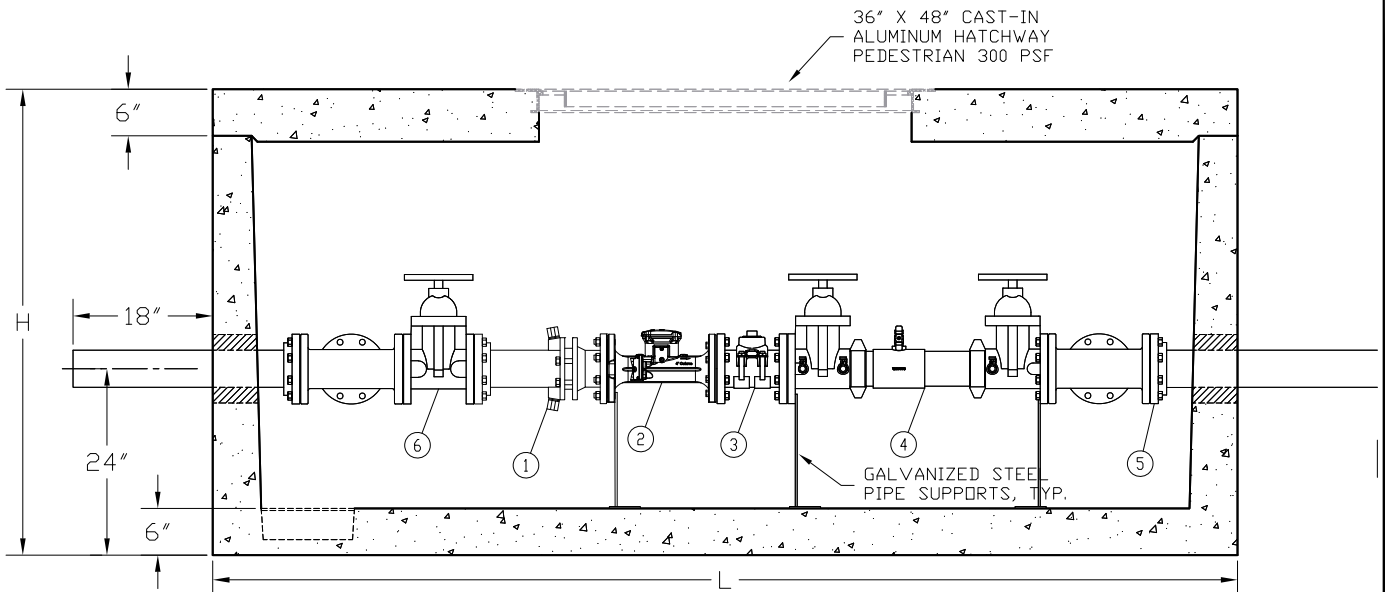
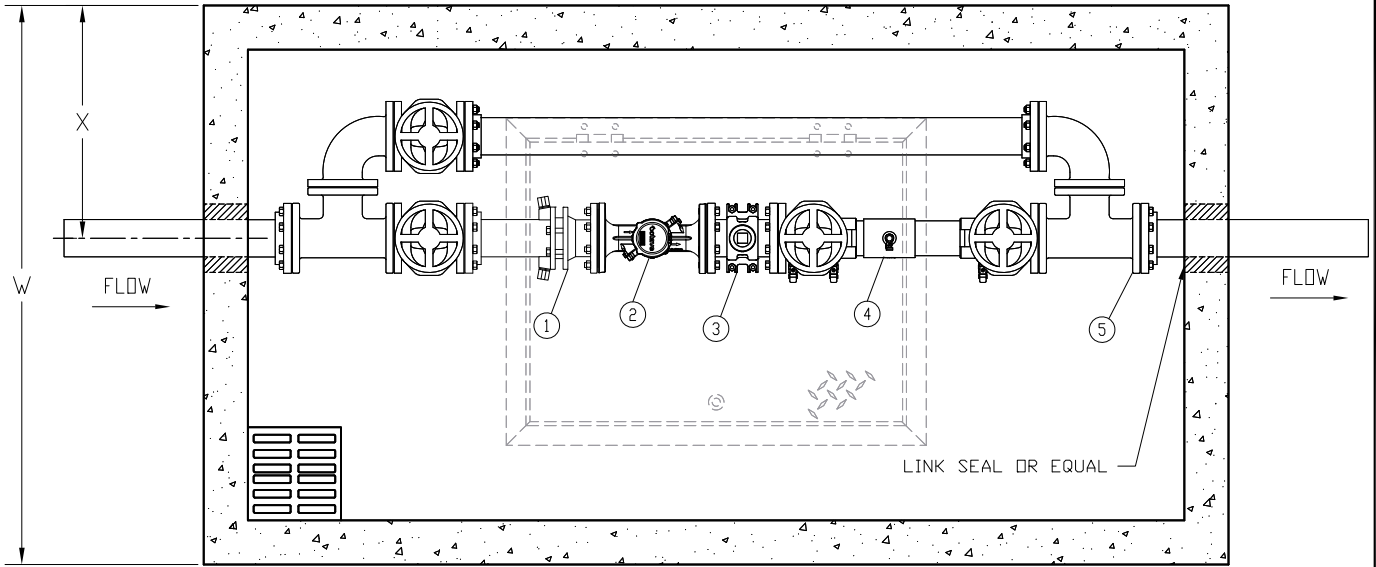

SIZE	L	W	H
3"	11'- 0"	6'- 0"	5'- 0"
4"	8'- 8"	5'- 0"	5'- 0"
6"	11'- 0"	6' 0"	5'- 0"

NOTES:

1. CONCRETE SHALL HAVE MIN STRENGTH OF 4200 PSI AT 28 DAYS. NO CAST IN PLACE VAULTS SHALL BE ALLOWED.
2. REINFORCEMENT SHALL BE GRADE 60. STEEL BAR SHALL CONFORM TO ASTM A615 ON REQUIRED CENTERS OR EQUALS.
3. ACCESS IS 1/4" ALUMINUM DIAMOND PLATE COVER WITH ALUMINUM FRAME. HATCH TO BE FURNISHED WITH 316 STAINLESS STEEL SLAM LOCK & HINGES.

ITEM	DESCRIPTION
1	FLANGE COUPLING ADAPTER
2	MASTER METER OCTAVE METER
3	STRAPPING SADDLE W/2" NPT PLUG
4	DOUBLE CHECK ASSEMBLY
5	FLG X P.E. SPOOL, D.I.
6	FLG NRS GATE VALVE

IRRIGATION WATER METER VAULT

CITY OF ROCKWALL

3", 4" OR 6" LINE



DATE
AUG '19

DRAWING NO.
R-4160

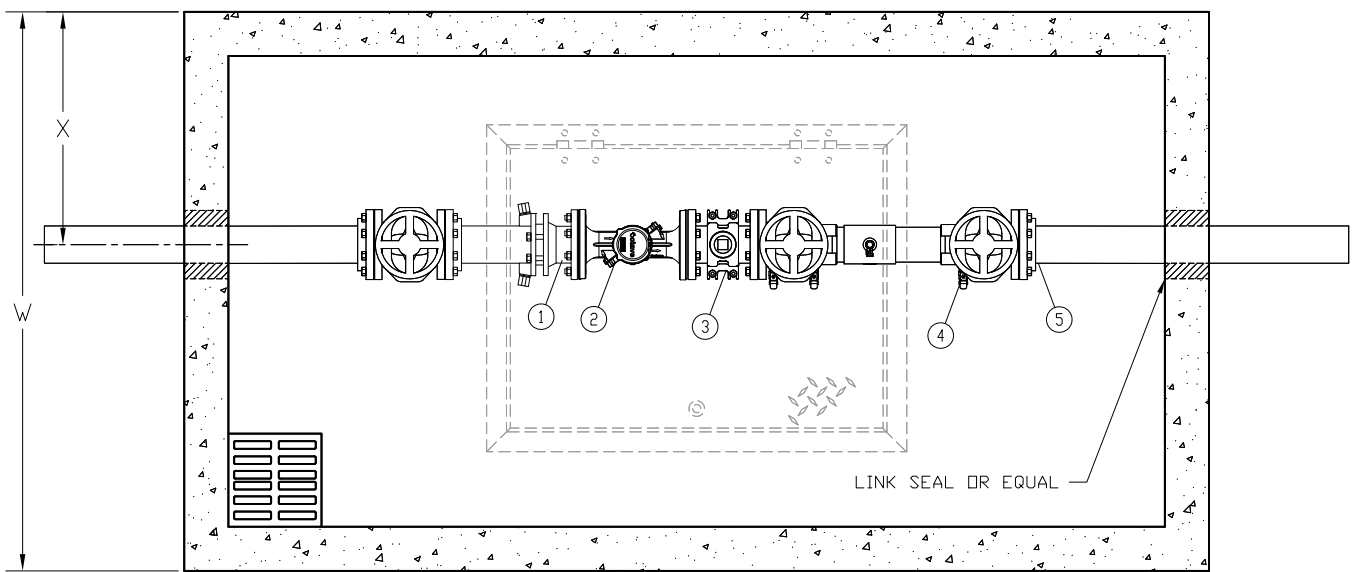

PLAN VIEW

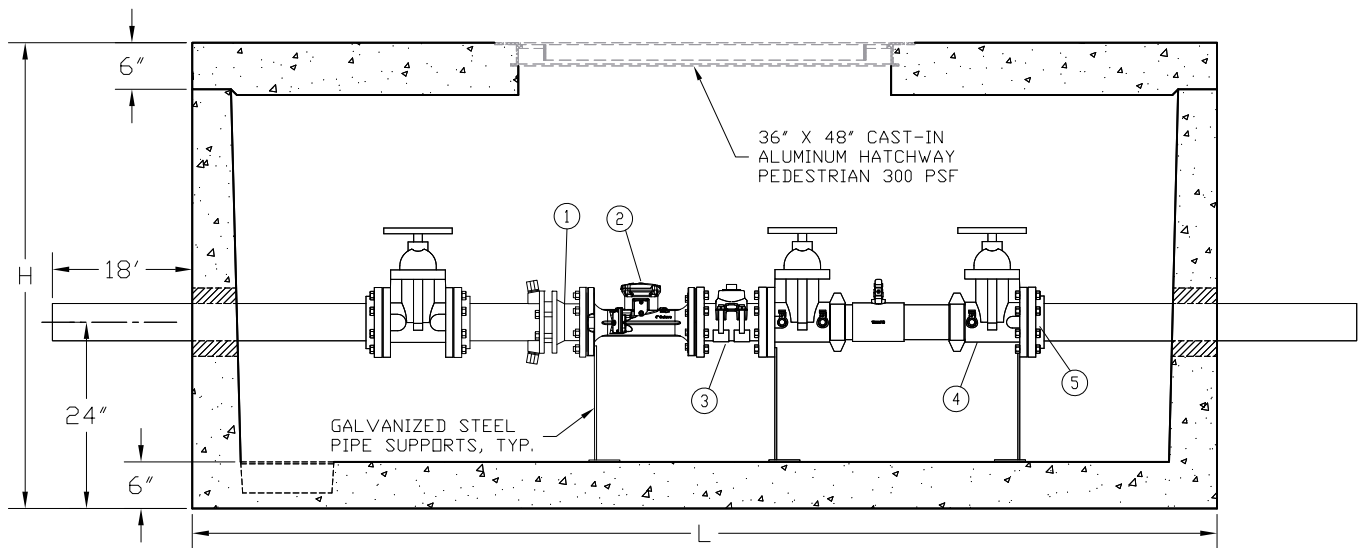

ELEVATION VIEW

SIZE	L	W	H
3"	11'- 0"	6'- 0"	5'- 0"
4"	11'- 0"	6'- 0"	5'- 0"
6"	11'- 0"	6'- 0"	5'- 0"

NOTES:

1. CONCRETE SHALL HAVE MIN STRENGTH OF 4200 PSI AT 28 DAYS. NO CAST IN PLACE VAULTS SHALL BE ALLOWED.
2. REINFORCEMENT SHALL BE GRADE 60. STEEL BAR SHALL CONFORM TO ASTM A615 ON REQUIRED CENTERS OR EQUALS.
3. ACCESS IS 1/4" ALUMINUM DIAMOND PLATE COVER WITH ALUMINUM FRAME. HATCH TO BE FURNISHED WITH 316 STAINLESS STEEL SLAM LOCK & HINGES.

ITEM	DESCRIPTION
1	FLANGE COUPLING ADAPTER
2	MASTER METER OCTAVE METER
3	STRAPPING SADDLE W/2" NPT PLUG
4	DOUBLE CHECK ASSEMBLY
5	FLG X P.E. SPOOL, D.I.

IRRIGATION WATER METER VAULT

CITY OF ROCKWALL

3", 4" OR 6" LINE



DATE
AUG '19

DRAWING NO.
R-4170

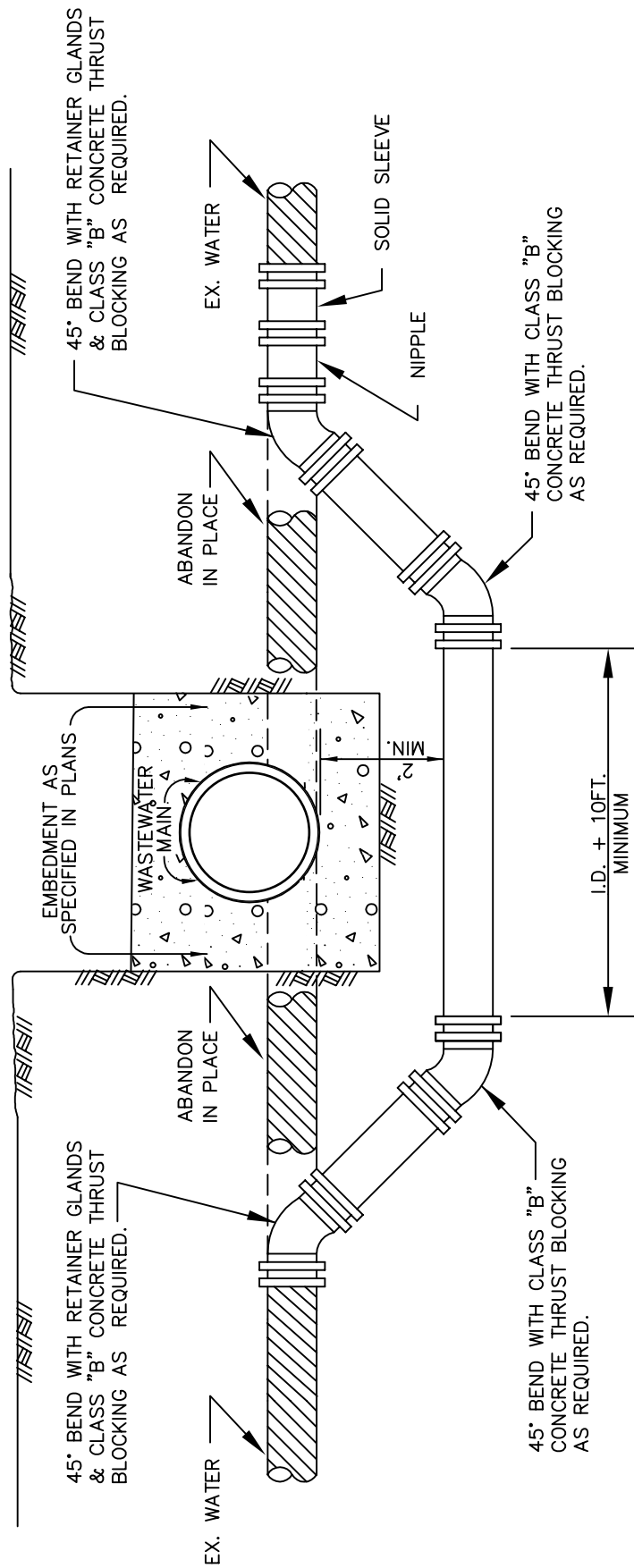

CONCRETE ENCASMENT SHALL ENCASE ENTIRE WASTEWATER MAIN. DEFLECT WATER LINE WHEN POSSIBLE.

STANDARD SPECIFICATION REFERENCE		506.6	
DATE		Mar. 2018	
STANDARD DRAWING NO.		R-4200	
CITY OF ROCKWALL			
WATER MAIN LOWERING			
BELOW WASTEWATER MAIN			
STANDARD DRAWING NO.		R-4200	