

NEMA 4X SS CONTROL PANEL  
 FLOOR STANDING ENCLOSURE  
 MINIMUM 72"x72"x16" BY HOFFMAN  
 OR WEIGMANN

PANEL COMPONENT SPECIFICATIONS

ITEM	MFR	MODEL	APPROVED ALTERNATE	NOTES
MAIN BREAKER	SQUARE D	LAL36400	EATON, GE, SIEMENS, A-B, WEG	
MOTOR CIRCUIT PROTECTOR	SQUARE D	LAL36250;150	EATON, GE, SIEMENS, A-B, WEG	
SOFT STARTER	SQUARE D	ALTISTART 48	EATON, GE, SIEMENS, A-B, DANFOSS, WEG	
BYPASS CONTACTOR	SQUARE D		EATON, GE, SIEMENS, A-B, DANFOSS, WEG	AC3 RATED, IEC
3-POS SWITCH, PILOT LIGHTS	SQUARE D	9001SK	EATON, GE, SIEMENS, A-B, WEG	
RELAYS	IDEC	RJ		
SURGE PROT. DEVICE (SPD2)	PHOENIX	-	SQUARE D, EATON, GE, SIEMENS, JOSLYN	SERIES
POWER SUPPLY 24VDC	SOLA	SDN-P	PHOENIX CONTACTORS	
TIME DELAY RELAY	SQUARE D	9050JCK	IDEC	
PUMP 1,2 MONITOR RELAY	FLYGT	MINICAS	N/A	SALVAGED FROM EXST. PNL.
PUMP 3 MONITOR RELAY	FLYGT	MINICAS	N/A	NEW, DELIVERED BY OWNER
CONTROL POWER XFMR	SQUARE D	TYPE T	EATON, GE, SIEMENS, A-B	
ELAPSED TIME METER	ENM	T50B52	OR EQUAL	
STROBE	FEDERAL SGNL	LP3E	OR EQUAL	MOUNT ON TOP OF ENCL.
HORN	FEDERAL SGNL	350-120-30	OR EQUAL	MOUNT ON OUTSIDE DOOR

GENERAL NOTES:  
 MAXIMUM SIZE OF THE PUMP CONTROL PANEL INTERIOR BACKPLATE IS 68"x68".  
 ONE (1) LOOSE SUBMERSIBLE LEVEL PROBE WITH 1/1 SIGNAL ISOLATOR AND ONE (1) LOOSE POLYPHASER SHALL BE FURNISHED AS PART OF THE LIFT STATION CONTROL/SCADA SYSTEM. PANEL BUILDER AND KIMARK WILL COORDINATE WHO WILL INCLUDE THE PROBE, ISOLATOR AND THE POLYPHASER IN THEIR SCOPES.  
 KIMARK SHALL PROGRAM 3-PUMP ALTERNATION WITH: LEAD, LAG AND LAG2 PUMP. HI LEVEL TO ENERGIZE 12" ABOVE LAG2 PMP START.

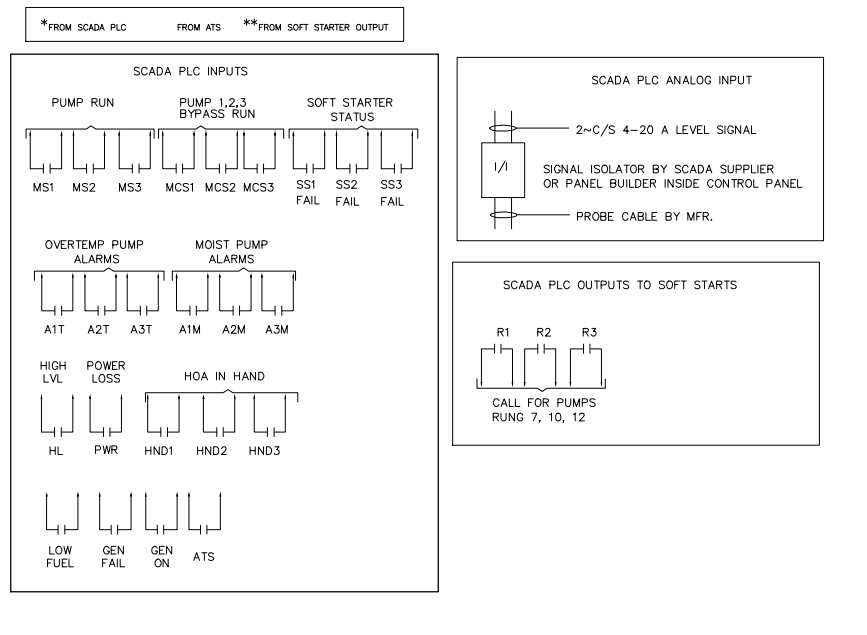

CONTROL PANEL WIRING DIAGRAM

FMI PROJECT #  
15023

THE SEAL APPEARING ON THIS DOCUMENT WAS AUTHORIZED BY DAMIR LULO, P.E. NO. 90370 ON 6/7/16

**Freeman-Millican, Inc.**  
 ENGINEERS - ARCHITECTS - PLANNERS  
 NORTH HOUSTON ROAD 17150, STE 500, DUBLIN, TX 75848-0550 (PH) 214-263-1187  
 TX, REG. ENGR. PERM F-2827